



SV630N Series Servo Drive User Guide



Industrial
Automation



Intelligent
Elevator



New Energy
Vehicle



Industrial
Robot



Rail
Transit



Data code 19011627 A00

Preface

Thank you for purchasing the SV630N series servo drive developed by Inovance.

The SV630N series high-performance AC servo drive covers a power range from 50 W to 7.5 kW. It supports the EtherCAT communication protocol. Over Ethernet communication interfaces, multiple SV630N servo drives can be controlled by the host controller.

The SV630N series servo drive supports stiffness level setting, inertia auto-tuning, and vibration suppression, simplifying the operation process. In addition, it achieves a quiet and stable operation when used with the MS1 series high-response servo motor equipped with an 18-bit single- or multi-turn absolute encoder.

The SV630N series servo drive aims to deliver fast and accurate control in automation equipment such as semi-conductor manufacturing equipment, chip mounters, PCB punching machines, transport machineries, food processing machineries, machine tools, and transmission machineries.

This user guide provides product information and instructions on installation, wiring, commissioning, and troubleshooting. First-time users must read through this user guide. For concerns regarding product functions or performance, contact Inovance for technical support.

Precautions
<ul style="list-style-type: none">◆ The drawings in the user guide are sometimes shown without covers or protective guards. Remember to install the covers or protective guards as specified first, and then perform operations in accordance with the instructions described in the user guide.◆ The drawings in the user guide are shown only for descriptions and may not match the product you have purchased.◆ This user guide is subject to change without notice due to product upgrade, specification modifications as well as accuracy and convenience improvement of the user guide.

Revision History

Date	Version	Description
January 2022	A00	First release

Standards Compliance

SV630N series servo drives and MS1 series servo motors have passed CE certification and comply with the following standards.

Name	Symbol	Directive		Standard	
CE certification		EMC directive	2014/30/EU	Servo drive and servo motor	EN 61800-3 EN55011 EN61000-6-2 EN61000-6-4
		LVD directive	2014/35/EU	Servo drive	EN 61800-5-1
				Servo motor	EN 60034-1
RoHS directive	2011/65/EU	EN 50581			

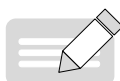

NOTE

- ◆ The product can comply with the preceding certification and standards only when you install and use it in accordance with the EMC-related electrical requirements described in this guide.
- ◆ The integrator who integrates this drive into other products and attaches the CE mark to the final assembly has the responsibility of ensuring compliance with CE standards and the European Directives.
- ◆ For more information on product certification, contact our agents or sales representatives.

Contents

Preface.....	2
Revision History.....	2
Standards Compliance.....	3
Safety Instructions	8
Safety Precautions	8
Safety Levels and Definitions	8
Safety Instructions	8
Safety Signs.....	12
1 Product Information.....	13
1.1 Introduction to the Servo Drive.....	13
1.1.1 Nameplate and Model Number.....	13
1.1.2 Components	14
1.1.3 Technical Specifications	20
1.1.4 Specifications of the Regenerative Resistor	25
1.2 Introduction to the Servo Motor	26
1.2.1 Motor Nameplate and Model Number	26
1.2.2 Components	27
1.2.3 Technical Specifications	28
1.3 Servo System Configurations	37
1.4 Cable Models	38
1.5 Communication Cable Options.....	40
1.6 Connector Kits	40
1.7 Servo System Wiring Diagram	41
2 Installation	46
2.1 Installing the Servo Drive.....	46
2.1.1 Installation Location	46
2.1.2 Environment Conditions.....	47
2.1.3 Dimension Drawings	47
2.1.4 Installation	49
2.2 Installing the Servo Motor.....	51
2.2.1 Installation Location	51
2.2.2 Installation Environment	51
2.2.3 Installation Precautions.....	52

2.2.4 Dimension Drawings	54
3 Wiring	61
3.1 Terminal Pin Layout	63
3.2 Wiring of the Main Circuit.....	66
3.2.1 Main Circuit Terminals	66
3.2.2 Wiring Example of the Regenerative Resistor.....	69
3.2.3 Specifications of Main Circuit Cables.....	70
3.2.4 Wiring Example of the Power Supply	73
3.2.5 Precautions for Main Circuit Wiring	75
3.2.6 Specifications of Main Circuit Options.....	76
3.3 Connecting the Servo Drive and Servo Motor Power Cables	77
3.4 Connecting the Servo Drive and Servo Motor Encoder Cables.....	80
3.5 Connecting Control Signal Terminal CN1.....	85
3.5.1 DI/DO Signals.....	86
3.5.2 Wiring of the Brake	89
3.6 Wiring of Communication Signals CN3/CN4	91
3.6.1 Pin Assignment of Communication Signal Connectors	92
3.6.2 Communication Cable Selection	92
3.6.3 Communication Connection with PC (RS232 Communication)	93
3.7 Definition and Connection of STO terminals	95
3.8 Anti-interference Measures for Electrical Wiring.....	97
3.8.1 Anti-interference Wiring Example and Grounding.....	98
3.8.2 Instructions for Use of the Noise Filter	99
3.9 Precautions for Use of Cables.....	100
4 Keypad Display and Operations	102
4.1 Introduction to the Keypad	102
4.2 Display.....	102
4.2.1 Mapping Relation Between Keypad Display and Operation Objects	103
4.2.2 Display Modes Switchover.....	103
4.2.3 Status Display	104
4.2.4 Parameter Display	104
4.2.5 Fault Display	106
4.2.6 Monitored Value Display	107
4.3 Parameter Settings.....	114
4.4 User Password	115

4.5 General Functions	116
4.5.1 Jog	116
4.5.2 Forced DI/DO Signals	117
5 Commissioning and Operation	124
5.1 Pre-running Check.....	125
5.2 Power-on.....	125
5.3 Jogging.....	125
5.4 General Parameter Settings.....	126
5.4.1 Direction of Rotation	126
5.4.2 Brake Settings.....	127
5.4.3 Regenerative Resistor Settings	132
5.5 Servo Running	139
5.6 Servo Stop.....	145
5.7 Conversion Factor Setting	151
6 Troubleshooting	153
6.1 Faults and Warnings.....	153
6.2 Communication Faults and Warning Codes.....	154
6.3 Solutions to Faults.....	157
6.4 Solutions to Warnings	181
6.5 Solutions to Communication Faults	187
7 Appendix	191
7.1 Standards Compliance.....	191
7.1.1 CE Certification	191
7.1.2 Low Voltage Directive Compliance.....	191
7.1.3 EMC Directive Compliance.....	192
7.1.4 Definition of EMC Terms.....	193
7.1.5 Selection of EMC Filters	193
7.1.6 Cable Requirements and Routing	198
7.1.7 Solutions to Leakage Current	199
7.1.8 Solutions to Common EMC Problems	200
7.1.9 UL Certification.....	201
7.2 List of Object Groups.....	202
Description of Object Groups	202
Object Group 1000h	202
Object Group 2000h	207



Object Group 6000h	233
SDO Abort Transfer Code	237
7.3 Safe Torque Off (STO) Function	238
7.3.1 Description of Technical Terms	238
7.3.2 Standards Compliance.....	241
7.3.3 General Safety Information	241
7.3.4 Specifications	243
7.3.5 Installation	244
7.3.6 Terminal and Wiring.....	244
7.3.7 Requirement for Commission, Operation and Maintenance	244
7.3.8 Safety Function: STO	246
7.3.9 Troubleshooting	249
7.3.10 Product Information	249
7.3.11 Precautions.....	251

Safety Instructions



Safety Precautions

- Before installing, using, and maintaining this equipment, read the safety information and precautions thoroughly, and comply with them during operations.
- To ensure the safety of humans and equipment, follow the signs on the equipment and all the safety instructions in this user guide.
- "CAUTION", "WARNING", and "DANGER" items in the user guide do not indicate all safety precautions that need to be followed; instead, they just supplement the safety precautions.
- Use this equipment according to the designated environment requirements. Damage caused by improper usage is not covered by warranty.
- Inovance shall take no responsibility for any personal injuries or property damage caused by improper usage.

Safety Levels and Definitions

- | | |
|--|---|
|  DANGER | Indicates that failure to comply with the notice will result in severe personal injuries or even death. |
|  WARNING | Indicates that failure to comply with the notice may result in severe personal injuries or even death. |
|  CAUTION | Indicates that failure to comply with the notice may result in minor or moderate personal injuries or equipment damage. |

Safety Instructions

Unpacking
<div style="border: 1px solid black; padding: 5px; margin-bottom: 10px;">  CAUTION </div> <ul style="list-style-type: none"> ◆ Check whether the packing is intact and whether there is damage, water seepage, damp, and deformation. ◆ Unpack the package by following the package sequence. Do not hit the package with force. ◆ Check whether there are damage, rust, or injuries on the surface of the equipment or equipment accessories. ◆ Check whether the number of packing materials is consistent with the packing list.
<div style="border: 1px solid black; padding: 5px; margin-bottom: 10px;">  WARNING </div> <ul style="list-style-type: none"> ◆ Do not install the equipment if you find damage, rust, or indications of use on the equipment or accessories. ◆ Do not install the equipment if you find water seepage, component missing or damage upon unpacking. ◆ Do not install the equipment if you find the packing list does not conform to the equipment you received.
Storage and Transportation

 CAUTION

- ◆ Store and transport this equipment based on the storage and transportation requirements for humidity and temperature.
- ◆ Avoid transporting the equipment in environments such as water splashing, rain, direct sunlight, strong electric field, strong magnetic field, and strong vibration.
- ◆ Avoid storing this equipment for more than three months. Long-term storage requires stricter protection and necessary inspections.
- ◆ Pack the equipment strictly before transportation. Use a sealed box for long-distance transportation.
- ◆ Never transport this equipment with other equipment or materials that may harm or have negative impacts on this equipment.

 WARNING

- ◆ Use professional loading and unloading equipment to carry large-scale or heavy equipment.
- ◆ When carrying this equipment with bare hands, hold the equipment casing firmly with care to prevent parts falling. Failure to comply may result in personal injuries.
- ◆ Handle the equipment with care during transportation and mind your step to prevent personal injuries or equipment damage.
- ◆ Never stand or stay below the equipment when the equipment is lifted by hoisting equipment.

Installation





 WARNING

- ◆ Thoroughly read the safety instructions and user guide before installation.
- ◆ Do not modify this equipment.
- ◆ Do not rotate the equipment components or loosen fixed bolts (especially those marked in red) on equipment components.
- ◆ Do not install this equipment in places with strong electric or magnetic fields.
- ◆ When this equipment is installed in a cabinet or final equipment, protection measures such as a fireproof enclosure, electrical enclosure, or mechanical enclosure must be provided. The IP rating must meet IEC standards and local laws and regulations.

 DANGER

- ◆ Equipment installation, wiring, maintenance, inspection, or parts replacement must be performed only by professionals.
- ◆ Installation, wiring, maintenance, inspection, or parts replacement must be performed only by experienced personnel who have been trained with necessary electrical information.
- ◆ Installation personnel must be familiar with equipment installation requirements and relevant technical materials.
- ◆ Before installing equipment with strong electromagnetic interference, such as a transformer, install an electromagnetic shielding device for this equipment to prevent malfunctions.

Wiring

 DANGER
<ul style="list-style-type: none">◆ Equipment installation, wiring, maintenance, inspection, or parts replacement must be performed only by professionals.◆ Never perform wiring at power-on. Failure to comply will result in an electric shock.◆ Before wiring, cut off all equipment power supplies. Wait at least 15 minutes before further operations because residual voltage exists after power-off.◆ Make sure that the equipment is well grounded. Failure to comply will result in an electric shock.◆ During wiring, follow the proper electrostatic discharge (ESD) procedures, and wear an antistatic wrist strap. Failure to comply will result in damage to internal equipment circuits.
 WARNING
<ul style="list-style-type: none">◆ Never connect the power cable to output terminals of the equipment. Failure to comply may cause equipment damage or even a fire.◆ When connecting a drive with the motor, make sure that the phase sequences of the drive and motor terminals are consistent to prevent reverse motor rotation.◆ Wiring cables must meet cross sectional area and shielding requirements. The shielding layer of the shielded cable must be reliably grounded at one end.◆ After wiring, make sure that no screws are fallen and cables are exposed in the equipment.
Power-on
 DANGER
<ul style="list-style-type: none">◆ Before power-on, make sure that the equipment is installed properly with reliable wiring and the motor can be restarted.◆ Before power-on, make sure that the power supply meets equipment requirements to prevent equipment damage or even a fire.◆ At power-on, unexpected operations may be triggered on the equipment. Therefore, stay away from the equipment.◆ After power-on, do not open the cabinet door and protective cover of the equipment. Failure to comply will result in an electric shock.◆ Do not touch any wiring terminals at power-on. Failure to comply will result in an electric shock.◆ Do not remove any part of the equipment at power-on. Failure to comply will result in an electric shock.
Operation
 DANGER
<ul style="list-style-type: none">◆ Do not touch any wiring terminals during operation. Failure to comply will result in an electric shock.◆ Do not remove any part of the equipment during operation. Failure to comply will result in an electric shock.◆ Do not touch the equipment enclosure, fan, or resistor for temperature detection. Failure to comply will result in heat injuries.◆ Signal detection must be performed only by professionals during operation. Failure to comply will result in personal injuries or equipment damage.
 WARNING
<ul style="list-style-type: none">◆ Prevent metal or other objects from falling into the device during operation. Failure to comply may result in equipment damage.◆ Do not start or stop the equipment using a contactor. Failure to comply may result in equipment damage.
Maintenance

<div data-bbox="288 208 464 264" data-label="Image"> </div> <ul data-bbox="285 282 1430 432" style="list-style-type: none"> ◆ Equipment installation, wiring, maintenance, inspection, or parts replacement must be performed only by professionals. ◆ Do not maintain the equipment at power-on. Failure to comply will result in an electric shock. ◆ Before maintenance, cut off all equipment power supplies and wait at least 15 minutes.
<div data-bbox="288 450 464 506" data-label="Image"> </div> <ul data-bbox="285 521 1430 584" style="list-style-type: none"> ◆ Perform daily and periodic inspection and maintenance for the equipment according to maintenance requirements and keep a maintenance record.
<p>Repair</p>
<div data-bbox="288 667 464 723" data-label="Image"> </div> <ul data-bbox="285 741 1430 889" style="list-style-type: none"> ◆ Equipment installation, wiring, maintenance, inspection, or parts replacement must be performed only by professionals. ◆ Do not repair the equipment at power-on. Failure to comply will result in an electric shock. ◆ Before inspection and repair, cut off all equipment power supplies and wait at least 15 minutes.
<div data-bbox="288 909 464 965" data-label="Image"> </div> <ul data-bbox="285 987 1430 1216" style="list-style-type: none"> ◆ Require for repair services according to the product warranty agreement. ◆ When the equipment is faulty or damaged, require professionals to perform troubleshooting and repair by following repair instructions and keep a repair record. ◆ Replace quick-wear parts of the equipment according to the replacement guide. ◆ Do not operate damaged equipment. Failure to comply may result in worse damage. ◆ After the equipment is replaced, perform wiring inspection and parameter settings again.
<p>Disposal</p>
<div data-bbox="288 1308 464 1364" data-label="Image"> </div> <ul data-bbox="285 1386 1430 1505" style="list-style-type: none"> ◆ Dispose of retired equipment by following local regulations or standards. Failure to comply may result in property damage, personal injuries, or even death. ◆ Recycle retired equipment by following industry waste disposal standards to avoid environmental pollution.

Safety Signs

■ Description of safety signs in the user guide



Read the user guide before installation and operation.



Reliably ground the system and equipment.



Danger!



High temperature!



Prevent personal injuries caused by machines.





High voltage!



Wait 15 minutes before further operations.

■ Description of safety signs on the equipment

For safe equipment operation and maintenance, comply with safety signs on the equipment, and do not damage or remove the safety labels. The following table describes the safety signs.

Safety Sign	Description
 DANGER	Never fail to connect the Protective Earth(PE) terminal. Read the user guide and follow the safety instructions before use.
 Hazardous Voltage	To prevent the risk of electric shock, do not touch terminals within 15 minutes after cutting off the power supply.
 High Temperature	To prevent the risk of burning, do not touch the heatsink when the power supply is ON.

1 Product Information

1.1 Introduction to the Servo Drive

1.1.1 Nameplate and Model Number

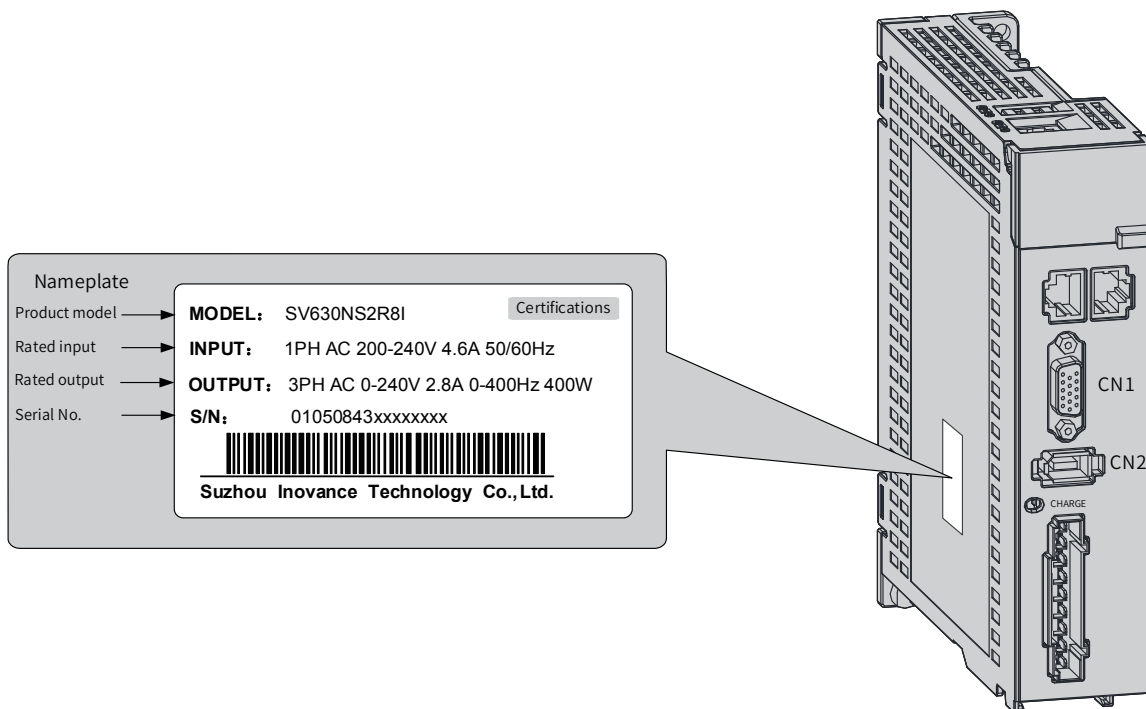
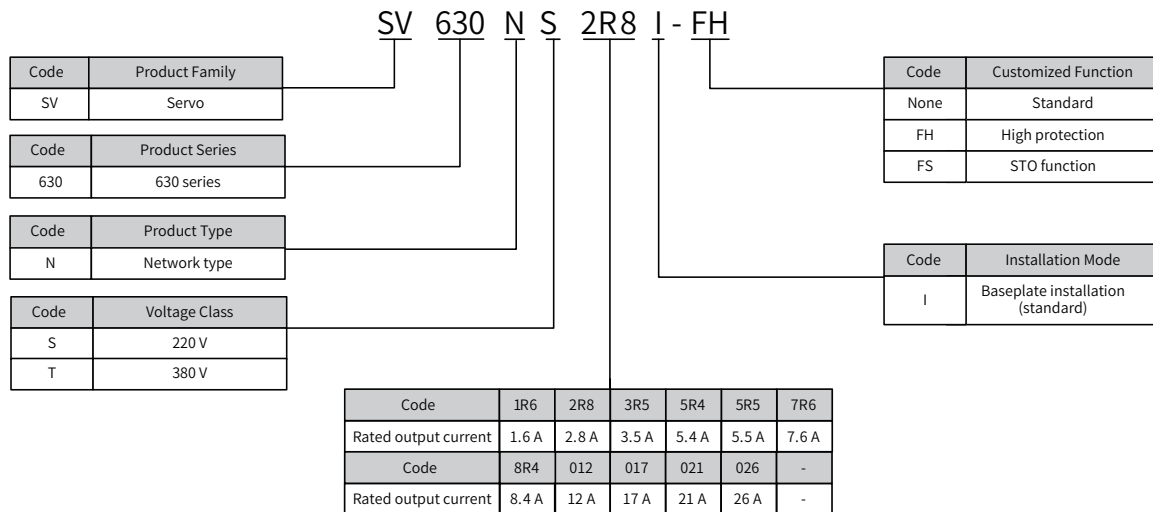
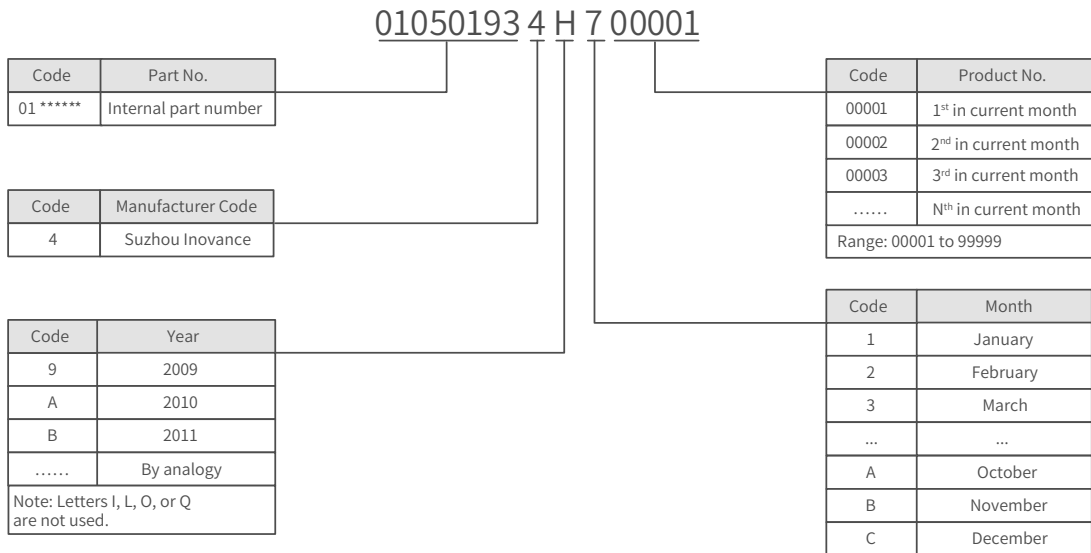

Figure 1-1 Nameplate and model number



Example: The serial number 010501934H700001 indicates the servo drive is manufactured in July 2017.

Figure 1-2 Encryption of the serial number (S/N)

1.1.2 Components

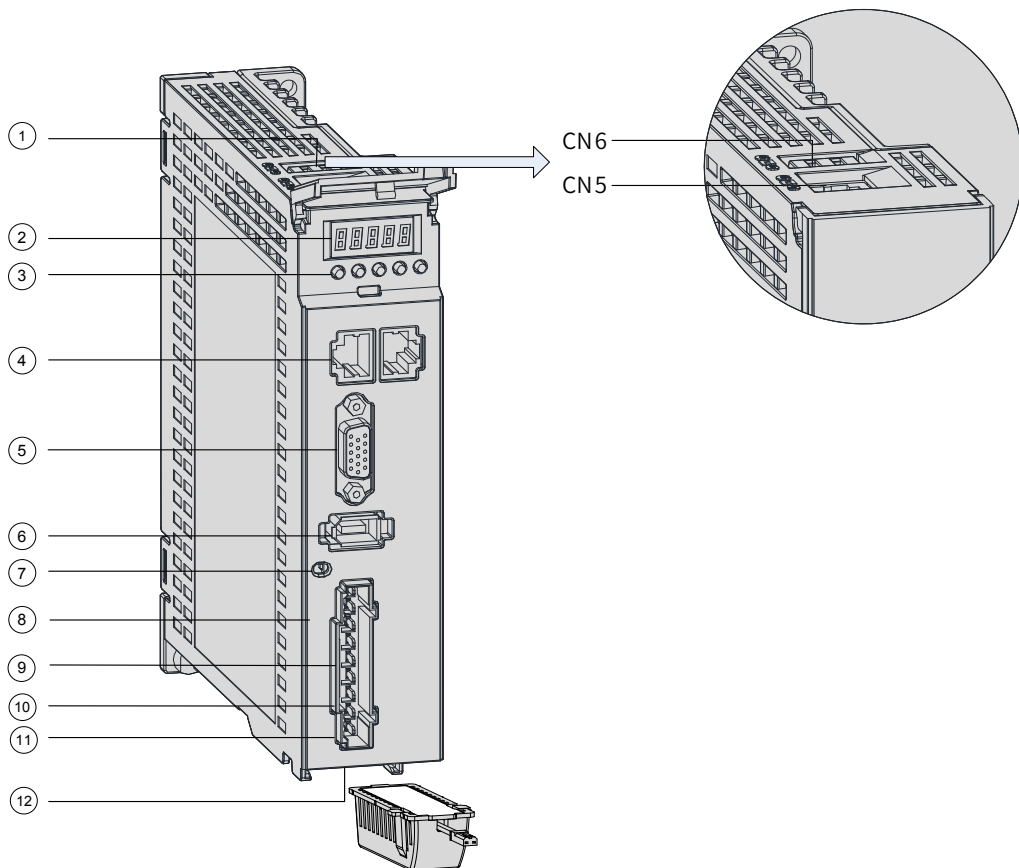

Figure 1-3 Layout of servo drives in size A

No.	Name	Description
①	CN6 and CN5	CN6: Functional safety terminal mainly used for functional safety, connected to the external functional safety signal CN5: Software tool communication terminal

No.	Name	Description
②	LED display (5-digit)	Used to display operation states and parameter settings of servo drives.
③	Buttons	<p>MODE: Used to switch parameters in sequence.</p> <p>△ : Used to increase the value of the blinking digit.</p> <p>▽ : Used to decrease the value of the blinking digit.</p> <p>◁ ◁ : Used to shift the blinking digit leftwards.</p> <p>(Held down: Used to turn to the next page when the display value is comprised of more than five digits.)</p> <p>SET: Used to save modifications and enter the next menu.</p>
④	CN3, CN4 (EtherCAT communication terminals)	<p>CN3 (IN): Connected to the master or the last slave.</p> <p>CN4 (OUT): Connected to the next slave.</p>
⑤	CN1 (control terminal)	Used by reference input signals and other I/O signals.
⑥	CN2 (terminal for connecting the encoder)	Connected to motor encoder terminals.
⑦	CHARGE (bus voltage indicator)	<p>Used to indicate that the bus capacitor carries electric charge.</p> <p>When this indicator lights up, electric charge may be still present in the bus capacitor of the servo drive even if the main circuit power supply is cut off.</p> <p>To prevent electrical shock, do not touch the power terminals when this indicator lights up.</p>
⑧	L1, L2 (power input terminals)	See the nameplate for the rated voltage of the power supply.
	P ⊕ , N ⊖ (DC bus terminals)	Used as the common DC bus for multiple servo drives.
⑨	P ⊕ , C (terminals for connecting external regenerative resistor)	When an external regenerative resistor is needed, connect it between terminals P ⊕ and C.
⑩	U, V, W (terminals for connecting the servo motor)	Connected to U, V, and W phases of the servo motor.
⑪	PE (grounding terminal)	Connected to the power supply ground and the motor grounding terminal.
⑫	Battery location	Used to hold the battery box of the absolute encoder.

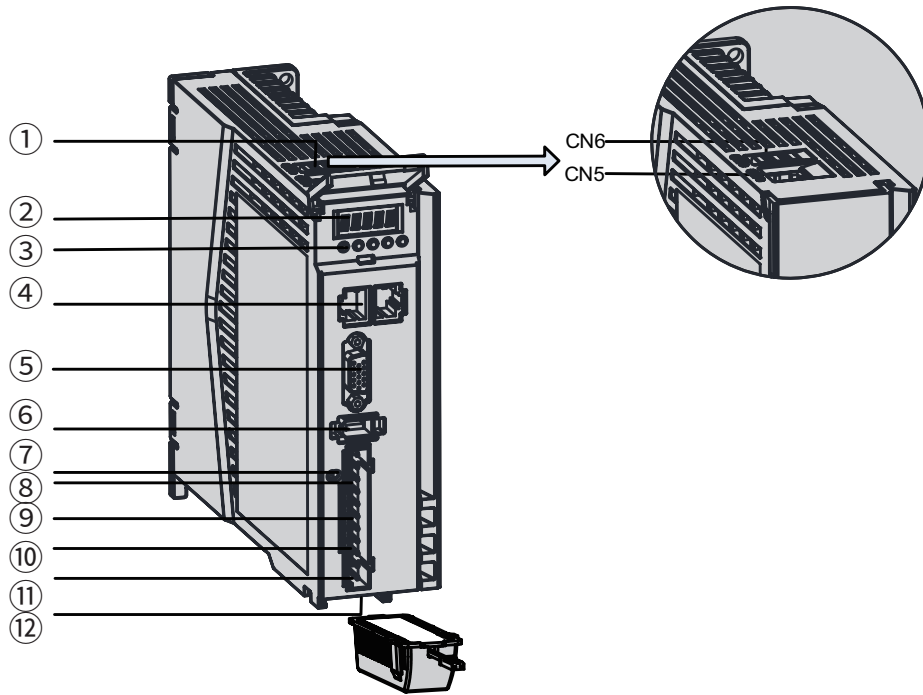

Figure 1-4 Layout of servo drives in size B

No.	Name	Description
①	CN6, CN5	CN6: Functional safety terminal mainly used for functional safety and connected to external functional safety signal CN5: Software tool communication terminal
②	LED display (5-digit)	Used to display operation states and parameter settings of servo drives.
③	Buttons	MODE: Used to switch the parameter No. in sequence. △ : Used to increase the set value of the blinking digit. ▽ : Used to decrease the set value of the blinking digit. ◀◀ : Used to shift the blinking digit leftwards. (Held down: Used to turn to the next page when the display value is comprised of more than five digits.) SET: Used to save modifications and enter the next level of menu.
④	CN3, CN4 (EtherCAT communication terminals)	CN3 (IN): Connected to the master or the last slave. CN4 (OUT): Connected to the next slave.
⑤	CN1 (control terminal)	Used for reference input signal and other I/O signals.
⑥	CN2 (terminal for connecting the encoder)	Connected to motor encoder terminals.
⑦	CHARGE (bus voltage indicator)	Used to indicate that the bus capacitor carries electric charge. When this indicator lights up, electric charge may be still present in the bus capacitor of the servo drive even if the main circuit power supply is cut off. To prevent electrical shock, do not touch the power terminals when this indicator lights up.

No.	Name	Description
⑧	L1, L2, L3 (power input terminals)	See the nameplate for the rated voltage of the power supply. Note: S5R5 (750 W) servo drives: Single-phase 220 V input, with 220 V power supply connected to L1 and L2
	P ⊕ , N ⊖ (DC bus terminals)	Used as the common DC bus for multiple servo drives.
⑨	P ⊕ , D, C (terminals for connecting external regenerative resistor)	Connect the regenerative resistor between terminals P ⊕ and C as needed. Remove the jumper between terminals P ⊕ and D before connecting the regenerative resistor.
⑩	U, V, W (terminals for connecting the servo motor)	Connected to U, V, and W phases of the servo motor.
⑪	PE (grounding terminal)	Connected to the power supply ground and motor grounding terminal.
⑫	Battery location	Used to hold the battery box of the absolute encoder.



NOTE

- ◆ Built-in regenerative resistors or jumper bars are not included in S1R6 and S2R8 models. If an external regenerative resistor is needed, connect it between terminals P ⊕ and C.
- ◆ To connect an external regenerative resistor to S5R5 models, remove the jumper bar between terminals P and D first and connect the resistor between terminals P ⊕ and C.

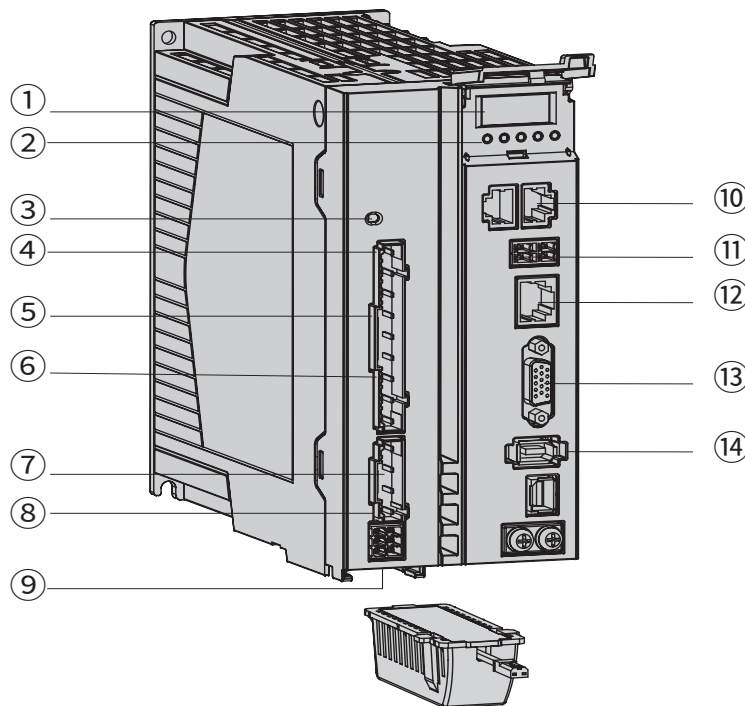

Figure 1-5 Components of servo drives in size C and Size D

No.	Name	Description
①	LED display (5-digit)	Used to display operation states and parameter settings of servo drives.

1 Product Information

No.	Name	Description
②	Buttons	<p>MODE: Used to switch the parameter No. in sequence.</p> <p>△ : Used to increase the set value of the blinking digit.</p> <p>▽ : Used to decrease the set value of the blinking digit.</p> <p>◀◀ : Used to shift the blinking digit leftwards.</p> <p>(Held down: Used to turn to the next page when the display value is comprised of more than five digits.)</p> <p>SET: Used to save modifications and enter the next level of menu.</p>
③	CHARGE (bus voltage indicator)	<p>Used to indicate that the bus capacitor carries electric charge.</p> <p>When this indicator lights up, electric charge may be still present in the bus capacitor of the servo drive even if the main circuit power supply is cut off.</p> <p>To prevent electrical shock, do not touch the power terminals when this indicator lights up.</p>
④	L1C, L2C (control circuit power input terminals)	See the nameplate for the rated voltage of the power supply.
⑤	R, S, T (main circuit power input terminals)	See the nameplate for the rated voltage of the power supply.
⑥	P ⊕ , D, C (terminals for connecting external regenerative resistor)	Connect the regenerative resistor between P ⊕ and C as needed. Remove the jumper between terminals P and D before connecting the regenerative resistor.
	P ⊕ , N ⊖ (DC bus terminals)	Used as the common DC bus for multiple servo drives.
⑦	U, V, W (terminals for connecting the servo motor)	Connected to U, V, and W phases of the servo motor.
⑧	PE (Grounding terminal)	Connected to the power supply ground and motor grounding terminal.
⑨	Battery location	Used to hold the battery box of the absolute encoder.
⑩	CN3, CN4 (EtherCAT terminal)	CN3(IN): Connected to the master or the last slave.
		CN4(OUT): Connected to the next slave.
⑪	CN6 (STO terminal)	Used to connect the external functional safety signal.
⑫	CN5	Used as the software tool communication terminal.
⑬	CN1 (control terminal)	Used by reference input signals and other I/O signals.
⑭	CN2 (terminal for connecting the encoder)	Connected to motor encoder terminal.

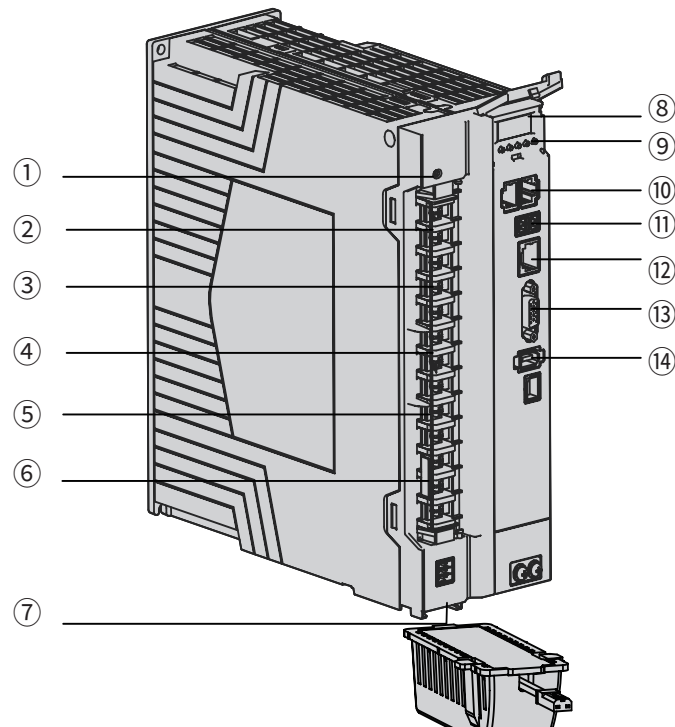

Figure 1-6 Components of servo drives in size E

No.	Name	Description
①	CHARGE (bus voltage indicator)	Used to indicate that the bus capacitor carries electric charge. When this indicator lights up, electric charge may be still present in the bus capacitor of the servo drive even if the main circuit power supply is cut off. To prevent electrical shock, do not touch the power terminals when this indicator lights up.
②	L1C, L2C (control circuit power input terminals)	See the nameplate for the rated voltage of the power supply.
③	R, S, T (main circuit power input terminals)	See the nameplate for the rated voltage of the power supply.
④	U, V, W (terminals for connecting the servo motor)	Connected to U, V, and W phases of the servo motor.
⑤	N2, N1 (terminals for connecting the external reactor)	Terminals N1 and N2 are jumpered by default. Remove the jumper before connecting the external DC reactor between N1 and N2.
⑥	P ⊕, D, C (terminals for connecting external regenerative resistor)	Connect the regenerative resistor between P and C as needed. Remove the jumper between terminals P ⊕ and D before connecting the regenerative resistor.
⑦	Battery location	Used to hold the battery box of the absolute encoder.
⑧	LED display (5-digit)	Used to display operation states and parameter settings of servo drives.

No.	Name	Description
⑨	Buttons	<p>MODE: Used to switch the parameter No. in sequence.</p> <p>△ : Used to increase the set value of the blinking digit.</p> <p>▽ : Used to decrease the set value of the blinking digit.</p> <p>◀◀ : Used to shift the blinking digit leftwards.</p> <p>(Held down: Used to turn to the next page when the display value is comprised of more than five digits.)</p> <p>SET: Used to save modifications and enter the next level of menu.</p>
⑩	CN3, CN4 (communication terminal)	<p>Connected in parallel internally.</p> <p>Connected to RS232 and RS485 devices.</p>
⑪	CN6 (STO terminal)	Used to connect the external functional safety signal.
⑫	CN5	Used as the software tool communication terminal.
⑬	CN1 (control terminal)	Used by reference input signals and other I/O signals.
⑭	CN2 (terminal for connecting the encoder)	Connected to the encoder terminal.

1.1.3 Technical Specifications

1 Electrical specifications

■ Single-phase 220 V servo drives

Item	Size A		Size B
	S1R6	S2R8	S5R5
Servo drive model: SV630N	S1R6	S2R8	S5R5
Continuous output current (Arms)	1.6	2.8	5.5
Maximum output current (Arms)	5.8	10.1	16.9
Main circuit power supply	Single-phase 200 VAC to 240 VAC, -10% to +10%, 50/60 Hz		
Control circuit power supply	Single-phase 200 VAC to 240 VAC, -10% to +10%, 50/60 Hz		
Braking function	<p>Servo drives in size A support only external regenerative resistors.</p> <p>Servo drives in size B carries built-in regenerative resistors as standard.</p>		

■ Three-phase 220 V servo drives

Item	Size C	Size D
	S7R6	S012
Servo drive model: SV630N	S7R6	S012
Continuous output current (Arms)	7.6	11.6
Maximum output current (Arms)	23	32
Main circuit power supply	Three-phase 200 VAC to 240 VAC, -10% to +10%, 50/60 Hz	
Control circuit power supply	Single-phase 200 VAC to 240 VAC, +10 to -10%, 50/60 Hz	
Braking function	A built-in regenerative resistor is included in the standard configuration.	



◆ S7R6 and S012 models support single-phase 220 V power supply and derating is not required upon single-phase power input.

■ Three-phase 380 V servo drives

Item	Size C		Size D		Size E		
Servo drive model: SV630N	T3R5	T5R4	T8R4	T012	T017	T021	T026
Continuous output current (Arms)	3.5	5.4	8.4	11.9	16.5	20.8	25.7
Maximum output current (Arms)	11	14	20	29.75	41.25	52.12	64.25
Main circuit power supply	Three-phase 380 VAC to 440 VAC, -10% to +10%, 50/60 Hz						
Control circuit power supply	Single-phase 380 VAC to 440 VAC, -10% to +10%, 50/60 Hz						
Braking function	A built-in regenerative resistor is included in the standard configuration.						

2 General specifications

Item		Description	
Basic specifications	Control mode	IGBT PWM control, sine wave current drive mode 220 V, 380 V: Single-phase/Three-phase full bridge rectification	
	Encoder feedback	23-bit absolute (optional) encoder, which can be used as an incremental encoder in the absence of the battery	
	Conditions for use	Ambient/Storage temperature ^[1]	0°C to 55°C (If the ambient temperature exceeds 45°C, derate 2% for every additional 1°C.)/-20°C to +70°C
		Ambient/Storage humidity	Below 90% RH (without condensation)
		Vibration/Impact resistance level	4.9 m/s ² , 19.6 m/s ²
		IP rating	IP20 (Terminals, which are rated at IP00, are excluded.)
		Pollution degree	PD2
Altitude	Below 1000 m. Derating is required for altitudes from 1000 m and 2000 m.		
Speed/Torque control mode	Performance	Speed control range	1:6000 (Under the rated torque load, the servo drive keeps running as long as the lower limit of the speed control range is not exceeded.)
		Speed loop bandwidth	3 kHz
		Torque control accuracy (repeatability)	±2%
		Soft startup time	0s to 65s (Acceleration and deceleration can be set separately.)
	Input signals	Speed reference	Source of network-type references: EtherCAT communication Local mode and local multi-speed supported
		Torque reference	

Item		Description	
Position control mode	Performance	Positioning time 1 ms to 10 ms	
	Input signal	Position reference Source of network-type references: EtherCAT communication Local mode supported	
	Digital input (DI) signal	Signal allocation change available 5 DIs P-OT (Positive limit switch) N-OT (Negative limit switch) HomeSwitch (Home switch) TouchProbe1 (Touch probe 1) TouchProbe2 (Touch probe 2)	
	Digital output (DO) signal	Signal allocation change available 3 DOs With-load capacity: 50 mA Voltage range: 5 V to 30 V S-RDY: Servo ready TGON: Motor rotation output Comparison output, brake output, EDM output	
Built-in functions	Overtravel (OT) prevention		Stopping immediately with P-OT and N-OT activated
	Protective functions		Providing protections against overcurrent, overvoltage, undervoltage, overload, main circuit detection error, heatsink over-temperature, overspeed, encoder error, CPU error, and parameter error
	LED display and CHARGE indicator		CHARGE indicator for the main power supply, 5-digit LED display
	Vibration suppression		Four notches (including two adaptive notches), 50 Hz to 5000 Hz
	Communication functions	Connection protocol	RS232
		Communication protocol	EtherCAT
		Multi-station communication	Maximum number of slaves: 255
		Axis address setting	No physical knob, set to 0...255 through software
Functions	Including status display, user parameter setting, monitoring information display, fault tracking display, jog and auto-tuning, and speed/torque reference signal observation		
Others		Gain auto-tuning, fault log, jog	

[1] Install the servo drive in environments that meet the allowable ambient temperature range. When it is installed inside an electric control cabinet, the temperature inside the cabinet must also be within this range.

3 Technical specifications of EtherCAT communication

	Item	Specification
Basic performance of EtherCAT slaves	Communication protocol	EtherCAT protocol
	Available services	CoE (PDO, SDO)
	Synchronization mode	DC - Distributed clock
	Physical layer	100BASE-TX
	Baud rate	100 Mbit/s (100Base-TX)
	Duplex mode	Full duplex
	Topological structure	Ring and linear
	Transmission medium	Shielded Cat 5e network cable or better
	Transmission distance	Less than 100 m between two nodes (with a proper environment and proper cables)
	Number of slaves	65535 by protocol, equal to or less than 100 in actual use
	EtherCAT frame length	44 bytes to 1498 bytes
	Process data	A maximum of 1486 bytes per Ethernet frame
	Synchronization jitter of two slaves	< 1 μ s
	Refresh time	About 30 μ s for 1000 DI/DOs About 100 μ s for 100 servo axes Different refresh times for different interfaces
Communication code error rate	10 ⁻¹⁰ Ethernet standard	
EtherCAT configuration units	Number of FMMU units	8
	Number of storage synchronization management units	8
	Process data RAM	8 KB
	Distributed clock	64-bit
	EEPROM capacity	32 kbit Initialization data written through EtherCAT master

4 Basic functions

The servo drive functions are listed below. See details in corresponding chapters.

Function	Description
Cyclic synchronous position mode	After the host controller generates and sends position references cyclically through the bus to the servo drive, it performs the positioning control process.
Cyclic synchronous velocity mode	After the host controller generates and sends speed references cyclically through the bus to the servo drive, it performs speed control.
Cyclic synchronous torque mode	After the host controller generates and sends torque references cyclically through the bus to the servo drive, it performs torque control.
Profile position mode	After the host controller sets parameters through the bus, the servo drive generates position references and performs positioning control process.
Profile velocity mode	After the host controller sets parameters through the bus, the servo drive generates speed references and performs speed control.

1 Product Information

Function	Description
Profile torque mode	After the host controller sets parameters through the bus, the servo drive generates torque references and performs torque control.
Homing mode	After the host controller selects the homing mode through parameters, the servo drive performs homing automatically with the position feedback set to the preset value.
Touch probe function	Latches the position information when an external DI signal or the motor phase-Z signal state changes.
High-resolution encoder	The encoder is of high performance with resolution up to 262144 PPR.
Mechanical characteristics analysis	Analyzes the resonance frequency and mechanical system characteristics through a PC with the Inovance software tool installed.
Gain auto-tuning	Generates gain parameters automatically to match present working conditions through just one parameter.
Gain switchover	Different gains can be applied, stopped, or switched through external terminals during running.
Torque disturbance observation	Automatically estimates the disturbance torque suffered by the system to perform compensation and reduce vibration.
Resonance suppression	Sets filter characteristics automatically to suppress mechanical system vibration after detecting the resonance point.
Torque reference filter	Suppresses the mechanical resonance generated during high-speed response of the servo drive.
Position first-order low-pass function	Enables smooth acceleration and deceleration.
Torque limit	Limits the output torque of the servo motor.
Speed limit	Limits the servo motor speed.
External regenerative resistor	Intends to be used in cases where the braking capacity of the built-in regenerative resistor is insufficient.
Input signal selection	Defines input functions such as emergency stop to corresponding pins.
Fault log	Contains the latest ten faults or used to clear the previous faults.
Status display	Displays the servo drive status through five LEDs.
External I/O display	Displays ON/OFF status of external I/O signals.
Forced output of output signals	Implements forced signal output not related to the servo drive status and detects the wiring of output signals.
Trial run mode	Runs the servo motor directly through the keypad without a start signal.
Inovance software tool	Used to execute parameter settings, trial run and status display through a PC.
Warning code output	Outputs a four-bit warning code when a warning occurs.
High-speed position comparison output	Outputs a DO signal with designated width after the servo drive reaches the preset target position.
Black box function	Captures the data before and after the designated condition. The data is read by software tool for further analysis.

1.1.4 Specifications of the Regenerative Resistor

Servo Drive Model		Specifications of the Built-in Regenerative Resistor		Min. Allowable Resistance (Ω)	Max. Braking Energy Absorbed by the Capacitor (J)
		Resistance (Ω)	Power (W)		
Single-phase 220 V	SV630NS1R6I	-	-	50	13.15
	SV630NS2R8I	-	-	45	26.29
	SV630NS5R5I	50	50	40	22.41
Single-phase/ Three-phase 220 V	SV630NS7R6I	25	80	20	26.70
	SV630NS012I			15	26.70
Three-phase 380 V	SV630NT3R5I	100	80	80	34.28
Three-phase 380 V	SV630NT5R4I	100	80	60	34.28
	SV630NT8R4I	50	80	45	50.41
	SV630NT012I			40	
	SV630NT017I	35	100	35	82.67
	SV630NT021I			25	100.82
	SV630NT026I				100.82

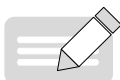

NOTE

- ◆ Select the external regenerative resistor according to actual operating conditions.
- ◆ S7R6 and S012 models support single-phase 220 V power supply and derating is not required upon single-phase power input.

1.2 Introduction to the Servo Motor

1.2.1 Motor Nameplate and Model Number

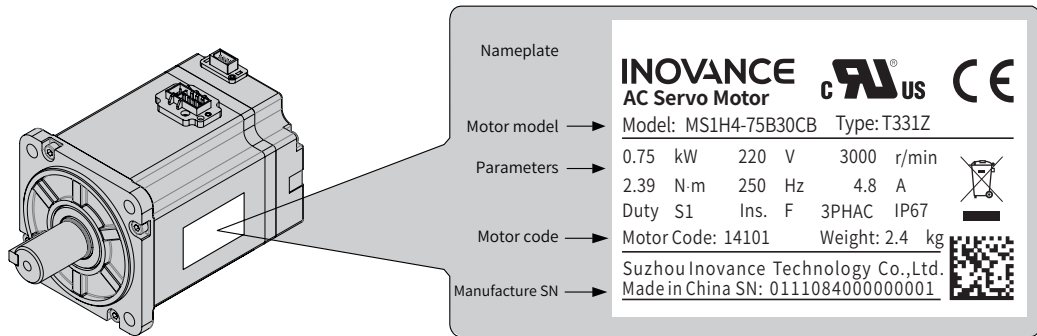
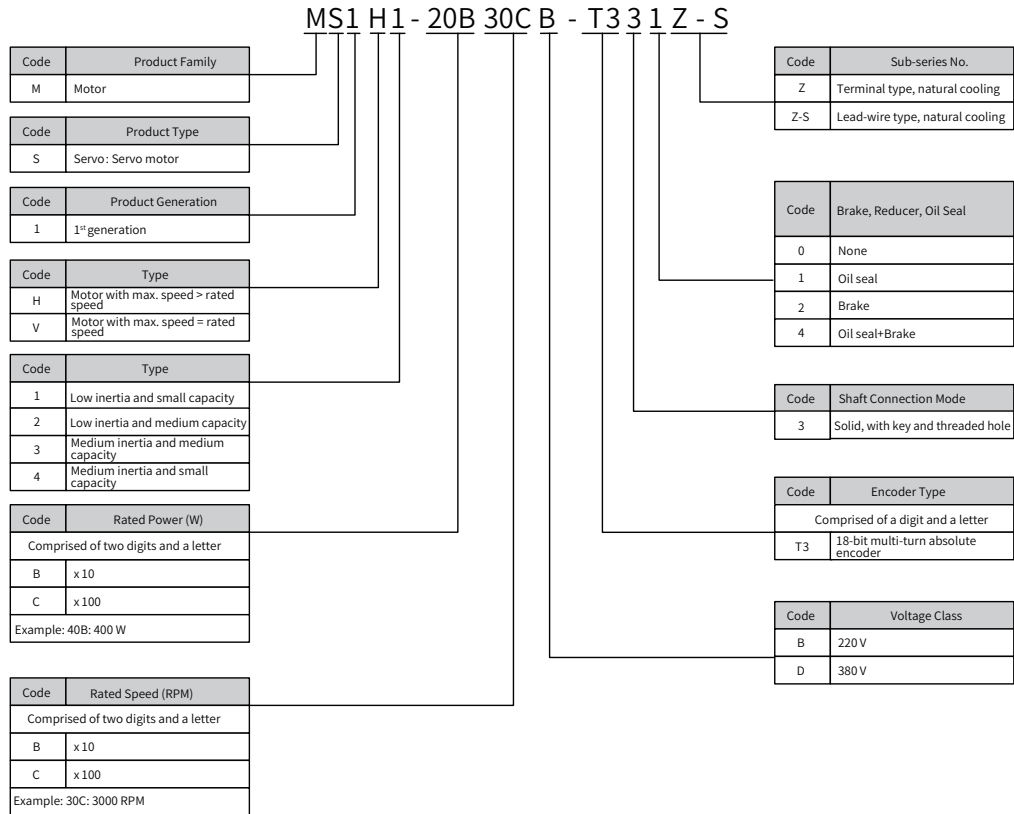

Figure 1-7 Model number and nameplate



◆ SV630N series servo drives can work with a motor equipped with a 18-bit single-turn or multi-turn encoder.

1.2.2 Components

■ Components of terminal-type motors

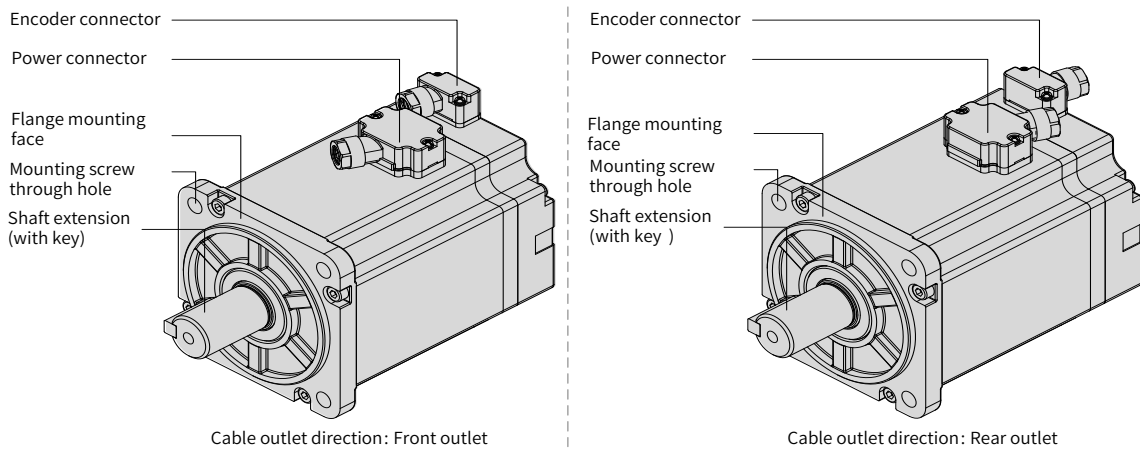

Figure 1-8 Components of MS1 series terminal-type motors

■ Components of lead wire-type motors

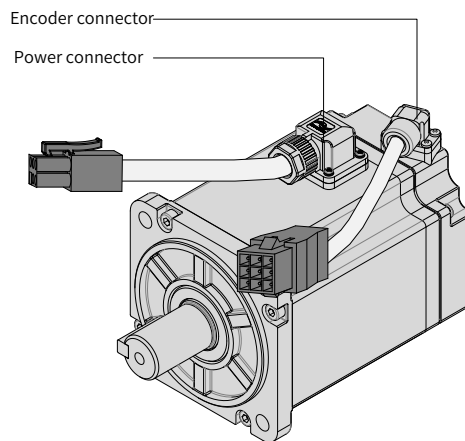

Figure 1-9 Components of MS1 series lead wire-type motors

■ Components of connector-type motors (flange sizes 100/130/180)

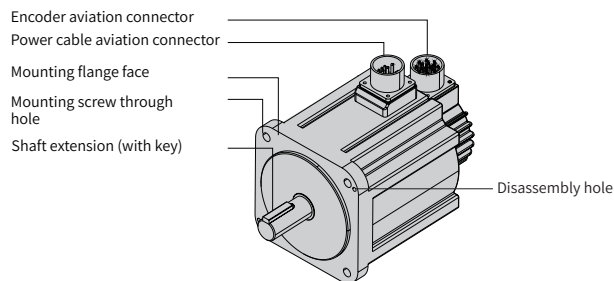

Figure 1-10 Components of MS1 series connector-type motors

1.2.3 Technical Specifications

1 Mechanical specifications of the motor

Item	Description
Duty type	Continuous
Vibration level	V15
Insulation resistance	500 VDC, above 10 MΩ
Ambient temperature	0°C to 40°C
Excitation mode	Permanent magnetic
Installation mode	Flange
Heat resistance level	Level F
Insulation voltage	1500 VAC, 1 min (220 V) 1800 VAC, 1 min (380 V)
IP rating of the enclosure	IP67 (except the shaft opening)
Ambient humidity	20% to 80% (without condensation)
Direction of rotation	Rotates counterclockwise (CCW) when viewed from the load side with a forward run command

2 Motor ratings

Model	Rated Output (kW) ^[1]	Rated Torque (N·m)	Max. Torque (N·m)	Rated Current (Arms)	Max. Current (Arms)	Rated Speed (RPM)	Max. Speed (RPM)	Torque Specifications (N·m/Arms)	Rotor Moment of Inertia (10 ⁻⁴ kg·m ²)	Voltage (V)
Ratings of MS1H1 (Vn = 3000 RPM, Vmax = 6000 RPM) Series Motors										
MS1H1-05B30CB	0.05	0.16	0.56	1.3	4.7	3000	6000	0.15	0.026 (0.028)	220
MS1H1-10B30CB	0.1	0.32	1.12	1.3	4.9			0.26	0.041 (0.043)	
MS1H1-20B30CB	0.2	0.64	2.24	1.5	5.8			0.46	0.207 (0.220)	
MS1H1-40B30CB	0.4	1.27	4.46	2.8	10.1			0.53	0.376 (0.390)	
MS1H1-55B30CB	0.55	1.75	6.13	3.8	15.0			0.49	1.06	
MS1H1-75B30CB	0.75	2.39	8.36	4.8	16.9			0.58	1.38 (1.43)	
MS1H1-10C30CB	1.0	3.18	11.1	7.6	28.0			0.46	1.75 (1.86)	
Ratings of MS1H2 (Vn = 3000 RPM, Vmax = 6000/5000 RPM) Series Motors										
MS1H2-10C30CB	1.0	3.18	9.54	7.5	23.00	3000	6000	0.47	1.87 (3.12)	220
MS1H2-15C30CB	1.5	4.90	14.7	10.8	32.00		5000	0.54	2.46 (3.71)	
MS1H2-10C30CD	1.0	3.18	9.54	3.65	11.00		6000	0.89	1.87 (3.12)	
MS1H2-15C30CD	1.5	4.90	14.7	4.50	14.00	3000	5000	1.07	2.46 (3.71)	380
MS1H2-20C30CD	2.0	6.36	19.1	5.89	20.00			1.19	3.06 (4.31)	
MS1H2-25C30CD	2.5	7.96	23.9	7.56	25.00			1.2	3.65 (4.90)	
MS1H2-30C30CD	3.0	9.8	29.4	10.00	30.00			1.2	7.72 (10.22)	
MS1H2-40C30CD	4.0	12.6	37.8	13.60	40.80			1.12	12.1 (14.6)	
MS1H2-50C30CD	5.0	15.8	47.6	16.00	48.00	1.29	15.4 (17.9)			
Ratings of MS1H3 (Vn = 1500 RPM, Vmax = 3000 RPM) Series Motors										

Model	Rated Output (kW) ^[1]	Rated Torque (N·m)	Max. Torque (N·m)	Rated Current (Arms)	Max. Current (Arms)	Rated Speed (RPM)	Max. Speed (RPM)	Torque Specifications (N·m/Arms)	Rotor Moment of Inertia (10 ⁻⁴ kg·m ²)	Voltage (V)
MS1H3-85B15CB	0.85	5.39	13.5	6.60	16.50	1500	3000	0.95	13.3 (14)	220
MS1H3-13C15CB	1.3	8.34	20.85	10.00	25.00			0.96	17.8 (18.5)	
MS1H3-85B15CD	0.85	5.39	13.5	3.30	8.25	1500	3000	1.87	13.3 (14)	380
MS1H3-13C15CD	1.3	8.34	20.85	5.00	12.50			1.87	17.8 (18.5)	
MS1H3-18C15CD	1.8	11.5	28.75	6.60	16.50	1500	3000	1.87	25 (25.7)	380
MS1H3-29C15CD	2.9	18.6	46.5	11.90	29.75			1.82	55 (57.2)	
MS1H3-44C15CD	4.4	28.4	71.1	16.50	40.50	1500	3000	1.90	88.9 (90.8)	380
MS1H3-55C15CD	5.5	35.0	87.6	20.85	52.00			1.74	107 (109.5)	
MS1H3-75C15CD	7.5	48.0	119	25.70	65.00	1500	3000	1.99	141 (143.1)	380
Ratings of MS1H4 (Vn = 3000 RPM, Vmax = 6000 RPM) Series Motors										
MS1H4-40B30CB	0.4	1.27	4.46	2.80	10.10	3000	6000	0.53	0.657 (0.667)	220
MS1H4-75B30CB	0.75	2.39	8.36	4.80	16.9			0.58	2 (2.012)	

[1] The motor with oil seal must be derated by 10% during use.

[2] Values inside parentheses "(") are for motors with brake.

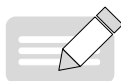

NOTE

◆ Values in the preceding table are obtained when motors equipped with the following heatsinks work with Inovance servo drives under an armature coil temperature of 20° C.

MS1H1/MS1H4: 250 mm x 250 mm x 6 mm (aluminum)

MS1H2-10C to 25C: 300 mm x 300 mm x 12 mm (aluminum)

MS1H2-30C to 50C: 400 mm x 400 mm x 20 mm (aluminum)

MS1H3-85B to 18C: 400 mm x 400 mm x 20 mm (iron)

MS1H3-29C to 75C: 360 mm x 360 mm x 25 mm (double-layer aluminum plate)

3 Motor overload characteristics

Load Ratio (%)	Operating Time (s)
120	230
130	80
140	40
150	30
160	20
170	17
180	15
190	12
200	10
210	8.5
220	7
230	6
240	5.5
250	5
300	3
350	2

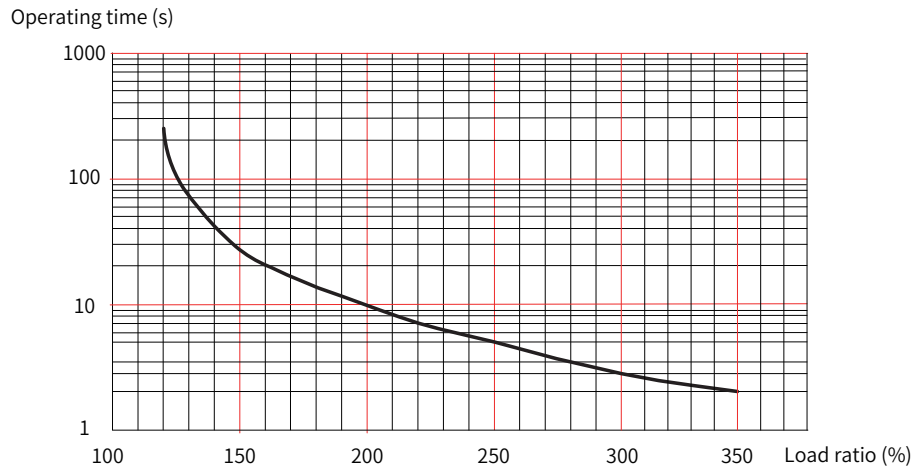

Figure 1-11 Motor overload curve



NOTE

- ◆ The maximum torque of H1 and H4 models is 3.5 times the rated torque.
- ◆ The maximum torque of H2 models is three times the rated torque.
- ◆ The maximum torque of H3 models (2.9 kW models excluded) is 2.5 times the rated torque.
- ◆ The maximum torque of 2.9 kW models is two times the rated torque.

4 Allowable radial and axial loads of the motor

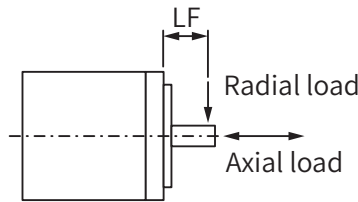

Figure 1-12 Radial and axial loads

Motor Model	Flange Size (mm)	LF (mm)	Allowable Radial Load (N)	Allowable Axial Load (N)
MS1H1-05B30CB	40	20	78	54
MS1H1-10B30CB	40	20	78	54
MS1H1-20B30CB	60	25	245	74
MS1H1-40B30CB	60	25	245	74
MS1H1-55B30CB	80	35	392	147
MS1H1-75B30CB	80	35	392	147
MS1H1-10C30CB	80	35	392	147
MS1H2-10C30CB	100	45	686	196
MS1H2-10C30CD	100	45	686	196
MS1H2-15C30CB	100	45	686	196
MS1H2-15C30CD	100	45	686	196
MS1H2-20C30CD	100	45	686	196
MS1H2-25C30CD	100	45	686	196
MS1H2-30C30CD	130	63	980	392
MS1H2-40C30CD	130	63	1176	392
MS1H2-50C30CD	130	63	1176	392
MS1H3-85B15CB	130	45	686	196
MS1H3-13C15CB	130	45	686	196
MS1H3-85B15CD	130	45	686	196
MS1H3-13C15CD	130	45	686	196
MS1H3-18C15CD	130	45	686	196

Motor Model	Flange Size (mm)	LF (mm)	Allowable Radial Load (N)	Allowable Axial Load (N)
MS1H3-29C15CD	180	79	1470	490
MS1H3-44C15CD	180	79	1470	490
MS1H3-55C15CD	180	113	1764	588
MS1H3-75C15CD	180	113	1764	588
MS1H4-40B30CB	60	25	245	74
MS1H4-75B30CB	80	35	392	147

5 Electrical specifications of the motor with brake

Motor Model	Holding Torque (N·m)	Supply Voltage (V _{DC}) ±10%	Rated Power (W)	Coil Resistance (Ω) (±7%)	Excitation Current (A)	Apply Time (ms)	Release Time (ms)	Backlash (°)
MS1H1-05B/10B	0.32	24	6.1	94.4	0.25	≤ 40	≤ 20	≤ 1.5
MS1H1-20B/40B MS1H4-40B	1.5		7.6	75.79	0.32	≤ 60	≤ 20	≤ 1.5
MS1H1/H4-75B	3.2		10	57.6	0.42	≤ 60	≤ 40	≤ 1.0
MS1H2-10C/15C/20C/25C	8		23	25	0.96	≤ 85	≤ 30	≤ 0.5
MS1H2-30C/40C/50C	16		27	21.3	1.13	≤ 100	≤ 60	≤ 0.5
MS1H3-85B/13C/18C	12		19.4	29.7	0.81	≤ 120	≤ 60	≤ 0.5
MS1H3-29C/44C/55C/75C	50		40	14.4	1.67	≤ 200	≤ 100	≤ 0.5



NOTE

- ◆ The brake cannot share the same power supply with other electrical devices. This is to prevent malfunction of the brake due to voltage or current drop caused by other working devices.
- ◆ It is recommended to use cables of 0.5 mm² and above.

6 Motor torque-speed characteristics

- MS1H1 (low inertia, small capacity)

- A █ Continuous working area
- B █ Short-term working area

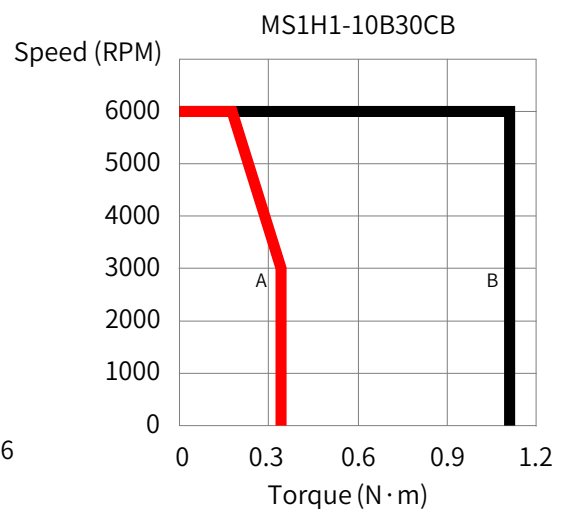
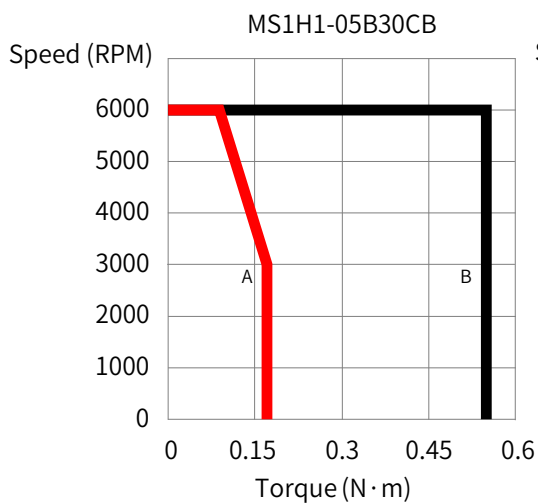

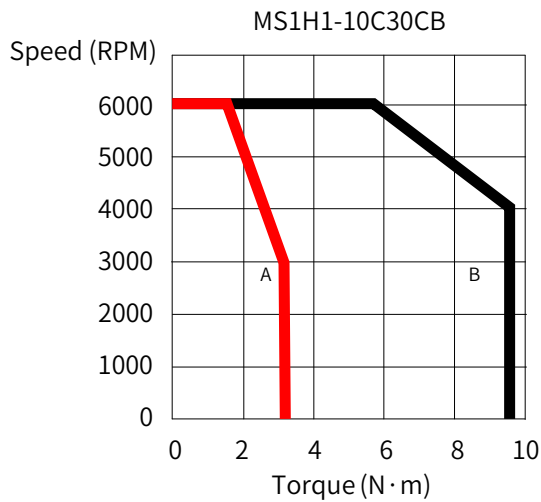
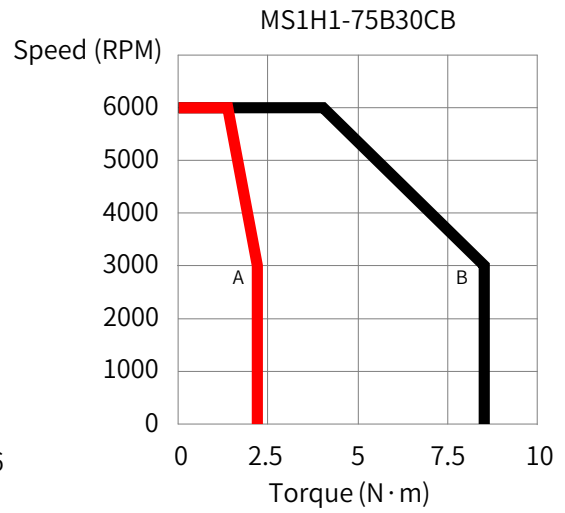
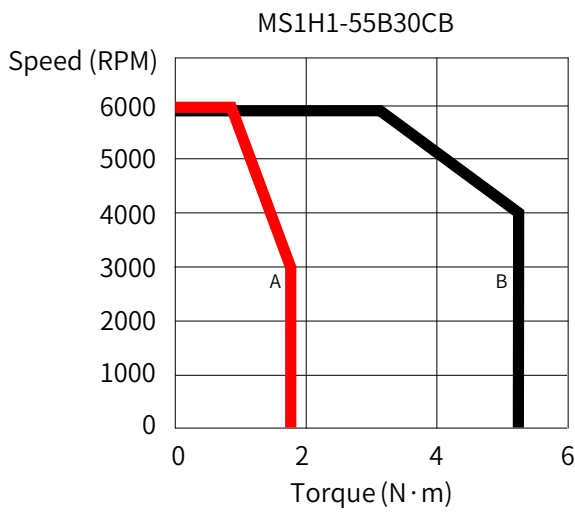
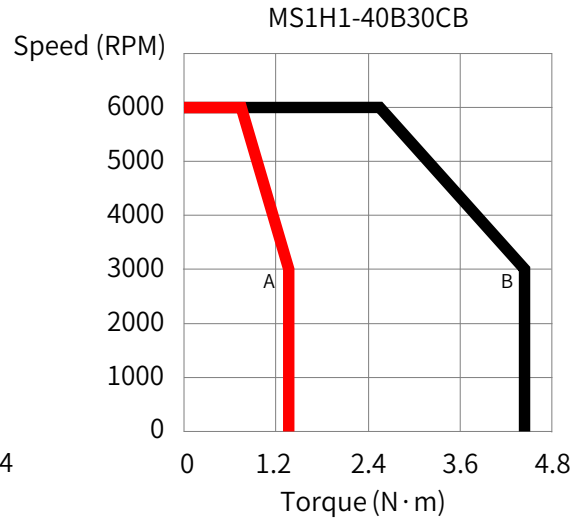
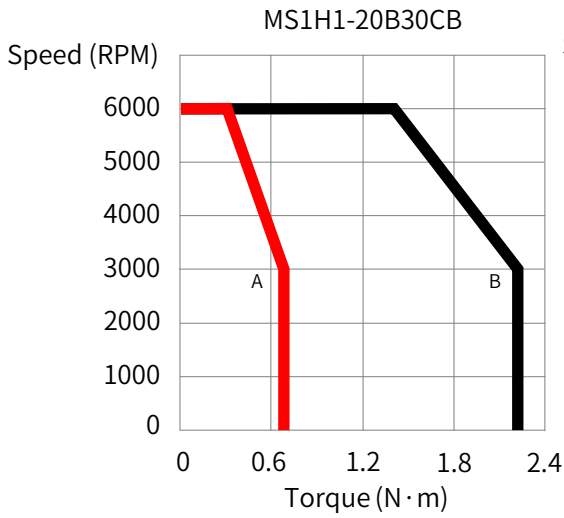

■ MS1H2 (low inertia, medium capacity)

- A █ Continuous working area
- B █ Short-term working area

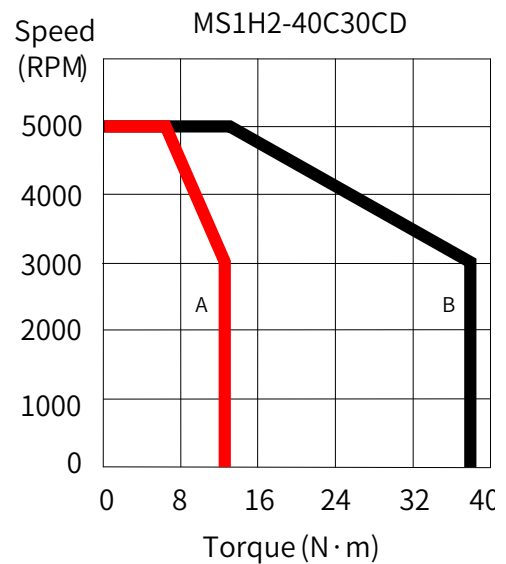
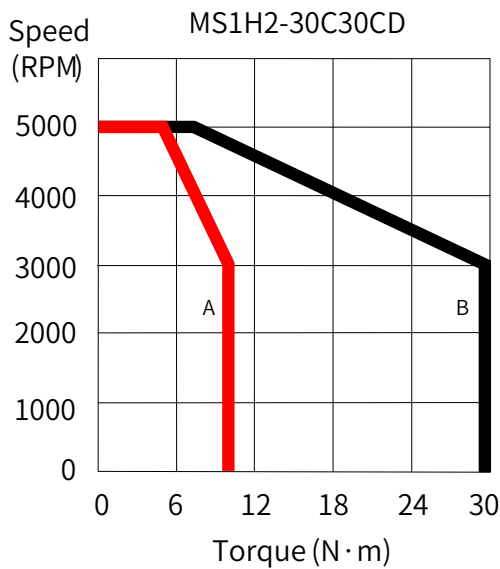
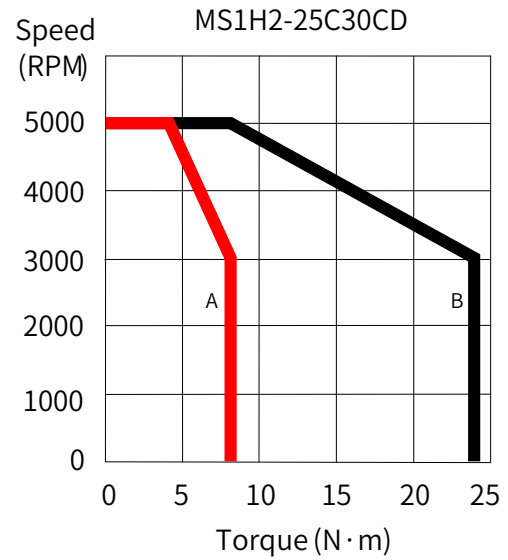
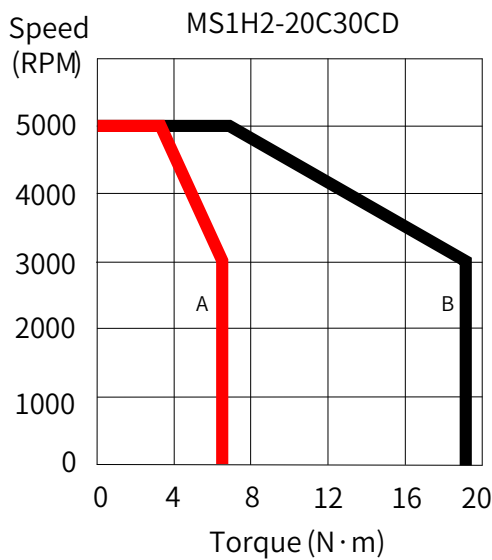
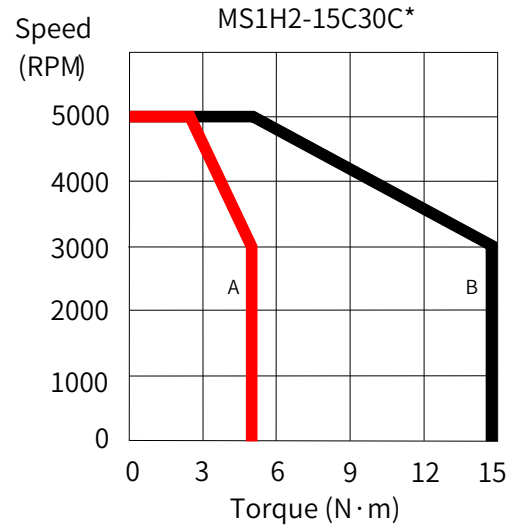
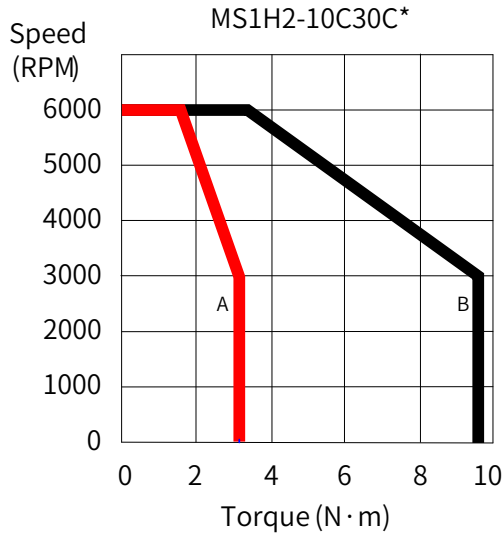

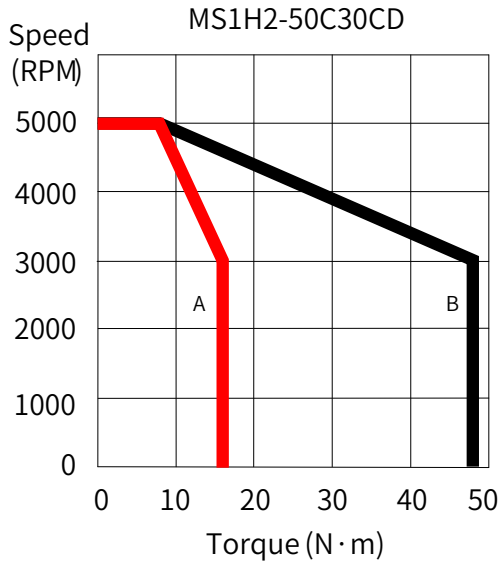

■ MS1H3 (medium inertia, medium capacity)

A — Continuous working area
 B — Short-term working area

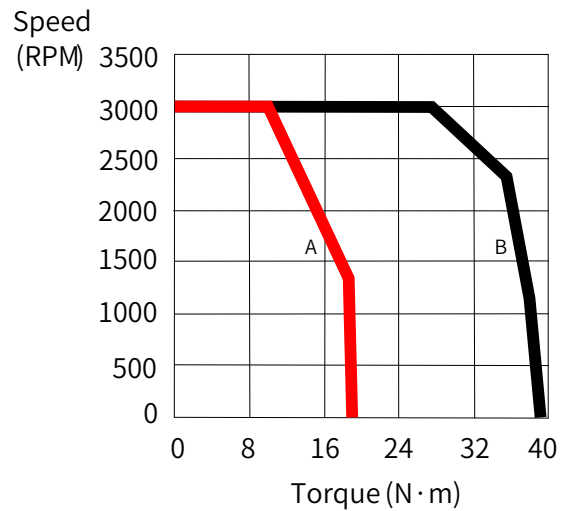
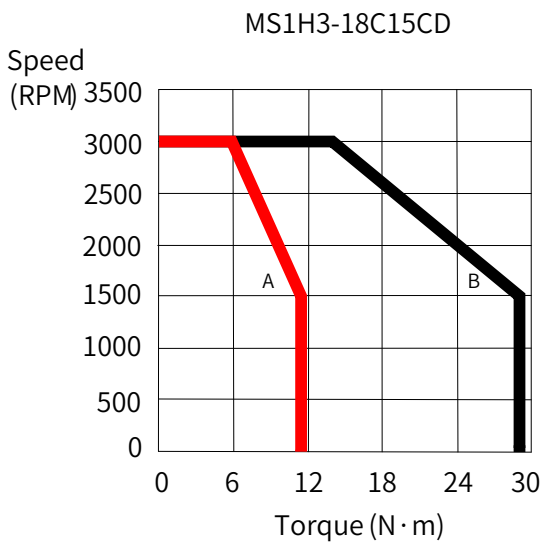
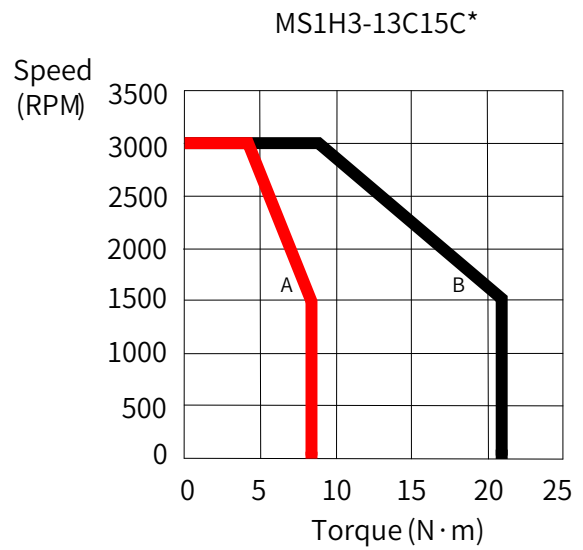
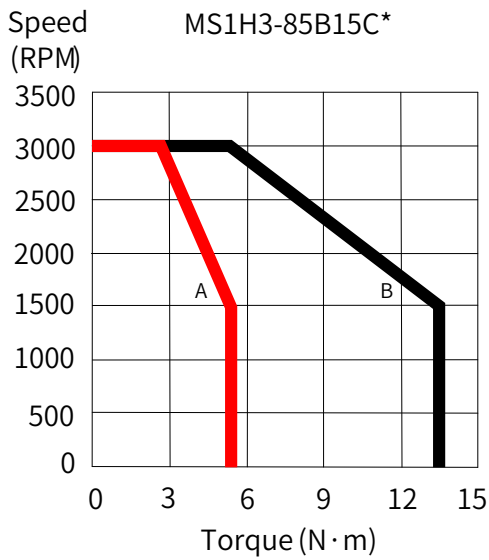

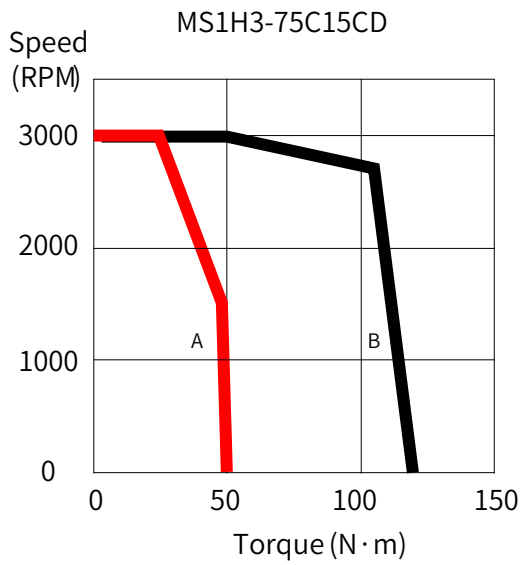
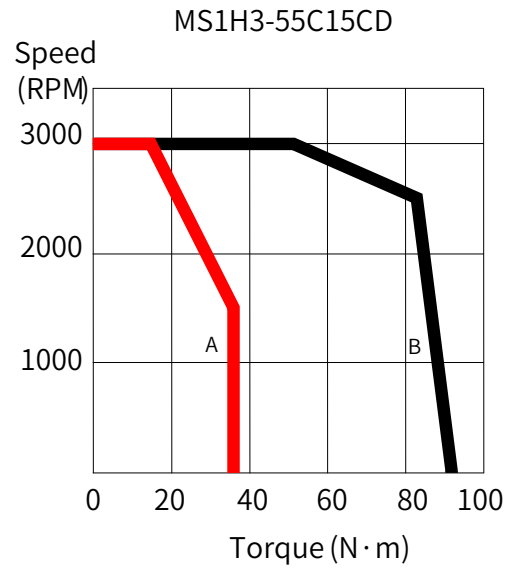
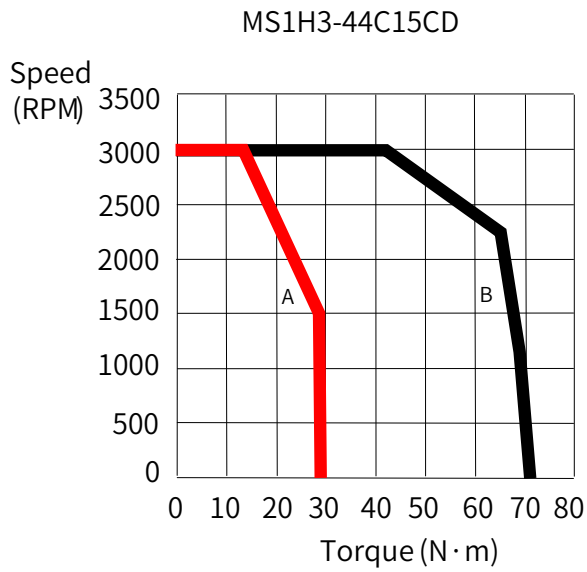

■ MS1H4 (medium inertia, small capacity)

- A █ Continuous working area
- B █ Short-term working area

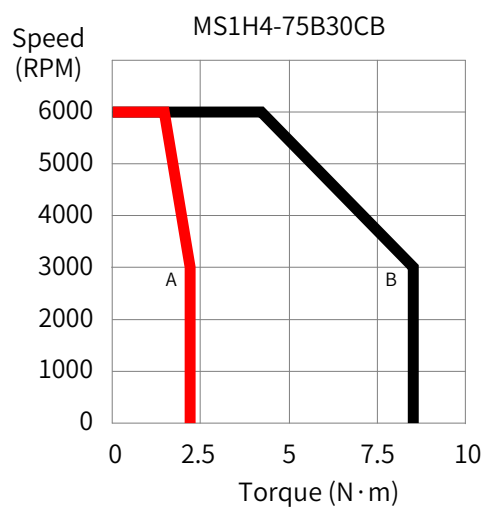
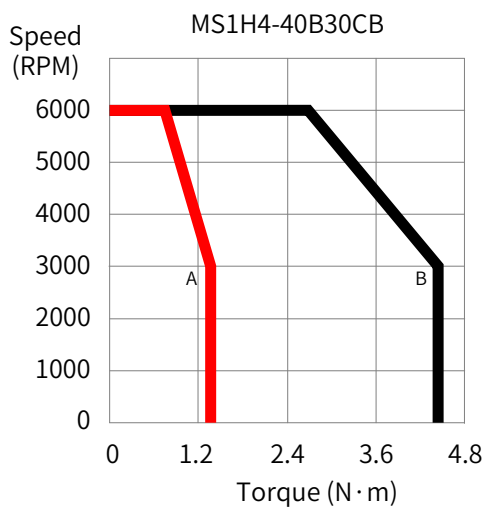

7 Derating curves

- Altitude-based derating curve

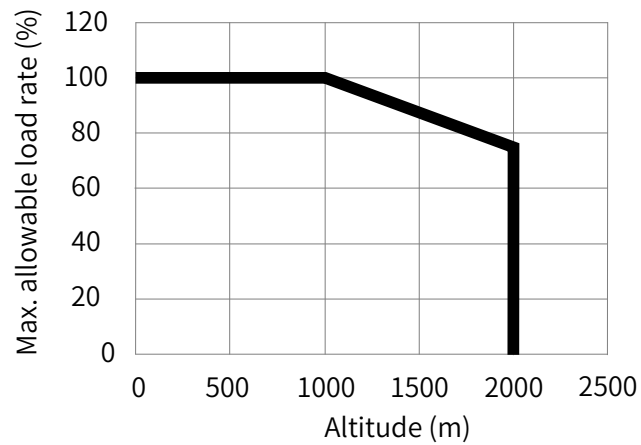

- Temperature-based derating curve

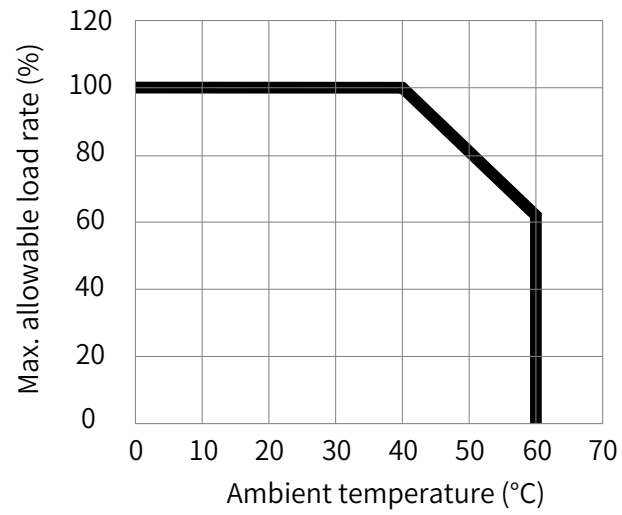

1.3 Servo System Configurations

■ 220 V:

Rated Speed (RPM)	Maximum Speed (RPM)	Capacity (W)	Servo Motor Model		Motor Flange Size	Servo Drive Model SV630N****I		Servo Drive Size	Servo Drive Code (H01-02)
						Single-phase 220 VAC	Three-phase 220 VAC		
3000	6000	50	MS1H1 (low inertia, small capacity)	05B30CB	40	S1R6	-	A	00002
		100		10B30CB	40	S1R6	-	A	00002
		200		20B30CB	60	S1R6	-	A	00002
		400		40B30CB	60	S2R8	-	A	00003
		550		55B30CB	80	S5R5	-	B	00005
		750		75B30CB	80	S5R5	-	B	00005
		1000		10C30CB	80	S7R6		C	00006
	1000	MS1H2 (low inertia, medium capacity)	10C30CB	100	S7R6		C	00006	
	5000	1500		15C30CB	100	S012		D	00007
1500	3000	850	MS1H3 (medium inertia, medium capacity)	85B15CB	130	S7R6		C	00006
1500	3000	1300	MS1H3 (medium inertia, medium capacity)	13C15CB	130	S012		D	00007
3000	6000	400	MS1H4 (medium inertia, small capacity)	40B30CB	60	S2R8	-	A	00003
		750		75B30CB	80	S5R5	-	A	00005



NOTE

- ◆ S7R6 and S012 models support single-phase 220 V power supply and derating is not required upon single-phase power input.

■ 380 V:

Rated Speed (RPM)	Maximum Speed (RPM)	Capacity (W)	Servo Motor Model	Motor Flange Size	Servo Drive Model SV630N****J	Servo Drive Size	Servo Drive Code (H01-02)	
					Three-phase 380 VAC			
3000	6000	1000	MS1H2 (low inertia, medium capacity)	10C30CD	100	T5R4	C	10002
	5000	1500		15C30CD	100	T5R4	C	10002
		2000		20C30CD	100	T8R4	D	10003
		2500		25C30CD	100	T8R4	D	10003
		3000		30C30CD	130	T012	D	10004
		4000		40C30CD	130	T017	E	10005
		5000		50C30CD	130	T017	E	10005
1500	3000	850	MS1H3 (medium inertia, medium capacity)	85B15CD	130	T3R5	C	10001
		1300		13C15CD	130	T5R4	C	10002
		1800		18C15CD	130	T8R4	C	10003
		2900		29C15CD	180	T012	D	10004
		4400		44C15CD	180	T017	E	10005
		5500		55C15CD	180	T021	E	10006
		7500		75C15CD	180	T026	E	10007

1.4 Cable Models

Table 1-1 Cables for MS1H1/MS1H4 terminal-type (Z) motors with front cable outlet

Cable Type	Cable Length (m)		
	3.0	5.0	10.0
Power cable (without brake)	S6-L-M107-3.0	S6-L-M107-5.0	S6-L-M107-10.0
Power cable (with brake)	S6-L-B107-3.0	S6-L-B107-5.0	S6-L-B107-10.0
Multi-turn absolute encoder cable	S6-L-P124-3.0	S6-L-P124-5.0	S6-L-P124-10.0
Single-turn absolute encoder cable	S6-L-P114-3.0	S6-L-P114-5.0	S6-L-P114-10.0

Table 1-2 Cables for MS1H1/MS1H4 terminal-type (Z) motors with rear cable outlet

Cable Type	Cable Length (m)		
	3.0	5.0	10.0
Power cable (without brake)	S6-L-M108-3.0	S6-L-M108-5.0	S6-L-M108-10.0
Power cable (with brake)	S6-L-B108-3.0	S6-L-B108-5.0	S6-L-B108-10.0
Multi-turn absolute encoder cable	S6-L-P125-3.0	S6-L-P125-5.0	S6-L-P125-10.0
Single-turn absolute encoder cable	S6-L-P115-3.0	S6-L-P115-5.0	S6-L-P115-10.0

Table 1-3 Cables for MS1H1/MS1H4 lead wire-type (S) motors with front cable outlet

Cable Type	Cable Length (m)		
	3.0	5.0	10.0
Power cable (without brake)	S6-L-M100-3.0	S6-L-M100-5.0	S6-L-M100-10.0
Power cable (with brake)	S6-L-B100-3.0	S6-L-B100-5.0	S6-L-B100-10.0
Multi-turn absolute encoder cable	S6-L-P120-3.0	S6-L-P120-5.0	S6-L-P120-10.0
Single-turn absolute encoder cable	S6-L-P110-3.0	S6-L-P110-5.0	S6-L-P110-10.0

Table 1-4 Cables for MS1H2 (below 3 kW) and MS1H3 (below 2.9 kW) motors

Cable Type	Cable Length (m)		
	3.0	5.0	10.0
Power cable (without brake)	S6-L-M111-3.0	S6-L-M111-5.0	S6-L-M111-10.0
Power cable (with brake)	S6-L-B111-3.0	S6-L-B111-5.0	S6-L-B111-10.0
Multi-turn absolute encoder cable	S6-L-P121-3.0	S6-L-P121-5.0	S6-L-P121-10.0
Single-turn absolute encoder cable	S6-L-P111-3.0	S6-L-P111-5.0	S6-L-P111-10.0

Table 1-5 Cables for MS1H2 (4 kW/5 kW) motors

Cable Type	Cable Length (m)		
	3.0	5.0	10.0
Power cable (without brake)	S6-L-M011-3.0	S6-L-M011-5.0	S6-L-M011-10.0
Power cable (with brake)	S6-L-B011-3.0	S6-L-B011-5.0	S6-L-B011-10.0
Multi-turn absolute encoder cable	S6-L-P121-3.0	S6-L-P121-5.0	S6-L-P121-10.0
Single-turn absolute encoder cable	S6-L-P111-3.0	S6-L-P111-5.0	S6-L-P111-10.0

Table 1-6 Cables for MS1H3 (2.9 kW) motors

Cable Type	Cable Length (m)		
	3.0	5.0	10.0
Power cable (without brake)	S6-L-M112-3.0	S6-L-M112-5.0	S6-L-M112-10.0
Power cable (with brake)	S6-L-B112-3.0	S6-L-B112-5.0	S6-L-B112-10.0
Multi-turn absolute encoder cable	S6-L-P121-3.0	S6-L-P121-5.0	S6-L-P121-10.0
Single-turn absolute encoder cable	S6-L-P111-3.0	S6-L-P111-5.0	S6-L-P111-10.0

Table 1-7 Cables for MS1H3 (above 2.9 kW) motors

Cable Type	Cable Length (m)		
	3.0	5.0	10.0
Power cable (without brake)	S6-L-M022-3.0	S6-L-M022-5.0	S6-L-M022-10.0
Power cable (with brake)	S6-L-B022-3.0	S6-L-B022-5.0	S6-L-B022-10.0
Multi-turn absolute encoder cable	S6-L-P121-3.0	S6-L-P121-5.0	S6-L-P121-10.0
Single-turn absolute encoder cable	S6-L-P111-3.0	S6-L-P111-5.0	S6-L-P111-10.0



NOTE

If highly flexible cables fit for cable carriers are needed, add a suffix "-T" to the end of the cable model.

1.5 Communication Cable Options

Model	Description
S6-L-T00-3.0	Cable for communication between the servo drive and PC
S6-L-T04-0.3	Cable for parallel communication of multiple servo drives
S6-L-T04-3.0	Cable for communication between the servo drive and the host controller

1.6 Connector Kits

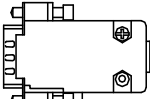
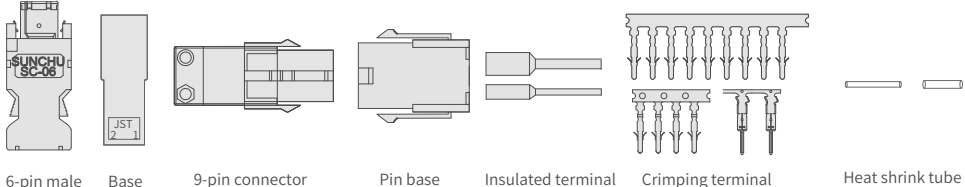
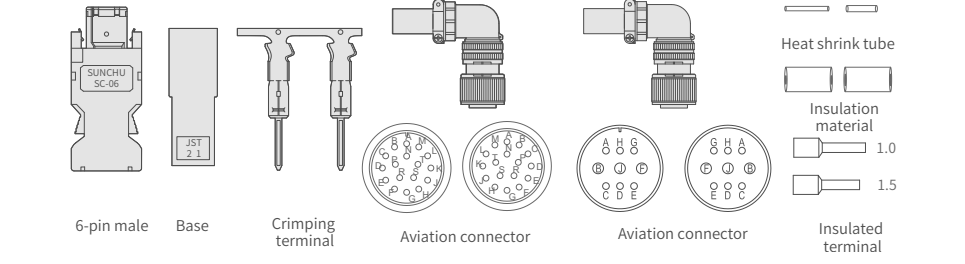
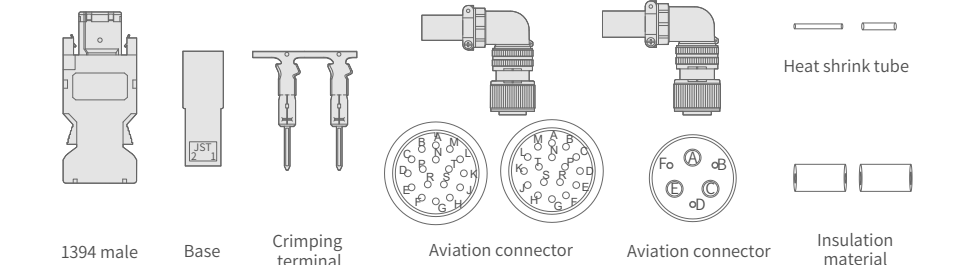
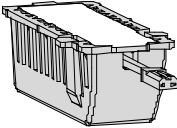
Connector Kit	Outline Drawing
S6-C6	 <p>(DB15C plug)</p>
S6-C26	 <p>6-pin male Base 9-pin connector Pin base Insulated terminal Crimping terminal Heat shrink tube</p>
S6-C29	 <p>6-pin male Base Crimping terminal Aviation connector Aviation connector Heat shrink tube Insulation material Insulated terminal</p>
S6-C39	 <p>1394 male Base Crimping terminal Aviation connector Aviation connector Heat shrink tube Insulation material</p>
S6-C4	

1.7 Servo System Wiring Diagram

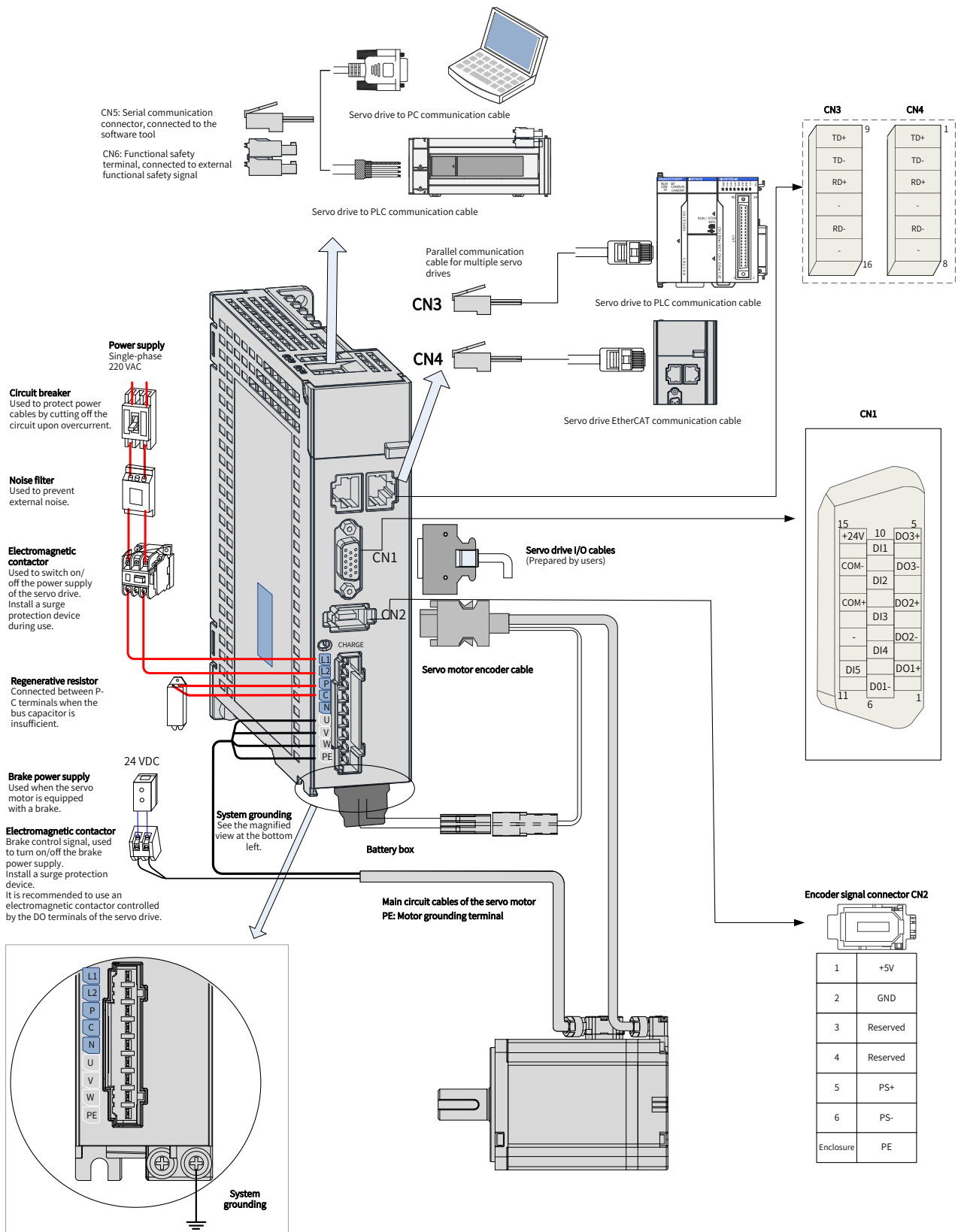

Figure 1-13 Wiring of single-phase 220 V systems

The servo drive is directly connected to an industrial power supply without isolation such as a transformer. To prevent damages in case of short circuit, install a fuse or a circuit breaker on the input power supply. To provide protection against electrical shock and/or fire, install a residual current device (RCD).

Do not run or stop the motor by using an electromagnetic contactor. As a high-inductance device, the motor may generate high voltage instantaneously, which may damage the contactor.

Ensure that the power capacity meets specific requirements when connecting an external control power supply or a 24 VDC power supply, especially when the power supply is used to power up multiple servo drives or brakes. Insufficient power supply will lead to insufficient supply current, resulting in failure of the servo drive or the brake. The brake must be powered by a 24 VDC power supply, and the brake power must match the motor model and meet the brake power requirements.

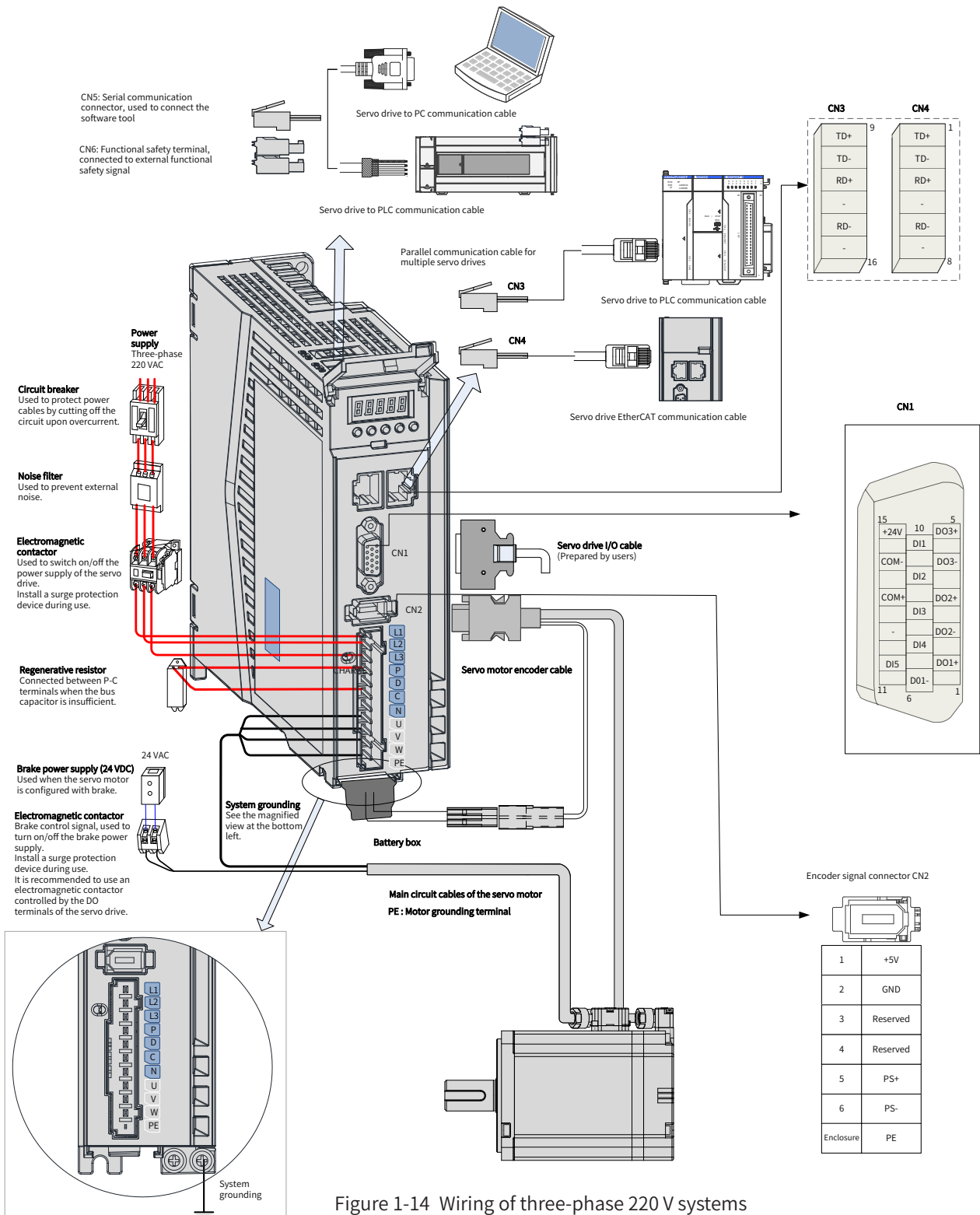

Figure 1-14 Wiring of three-phase 220 V systems

The servo drive is directly connected to an industrial power supply without isolation such as a transformer. To prevent damages in case of short circuit, install a fuse or a circuit breaker on the input power supply. To provide protection against electrical shock and/or fire, install a residual current device (RCD).

Do not run or stop the motor by using an electromagnetic contactor. As a high-inductance device, the motor may generate high voltage instantaneously, which may damage the contactor.

Ensure that the power capacity meets specific requirements when connecting an external control power supply or a 24 VDC power supply, especially when the power supply is used to power up multiple servo drives or brakes. Insufficient power supply will lead to insufficient supply current, resulting in failure of

the servo drive or the brake. The brake must be powered by a 24 VDC power supply, and the brake power must match the motor model and meet the brake power requirements.

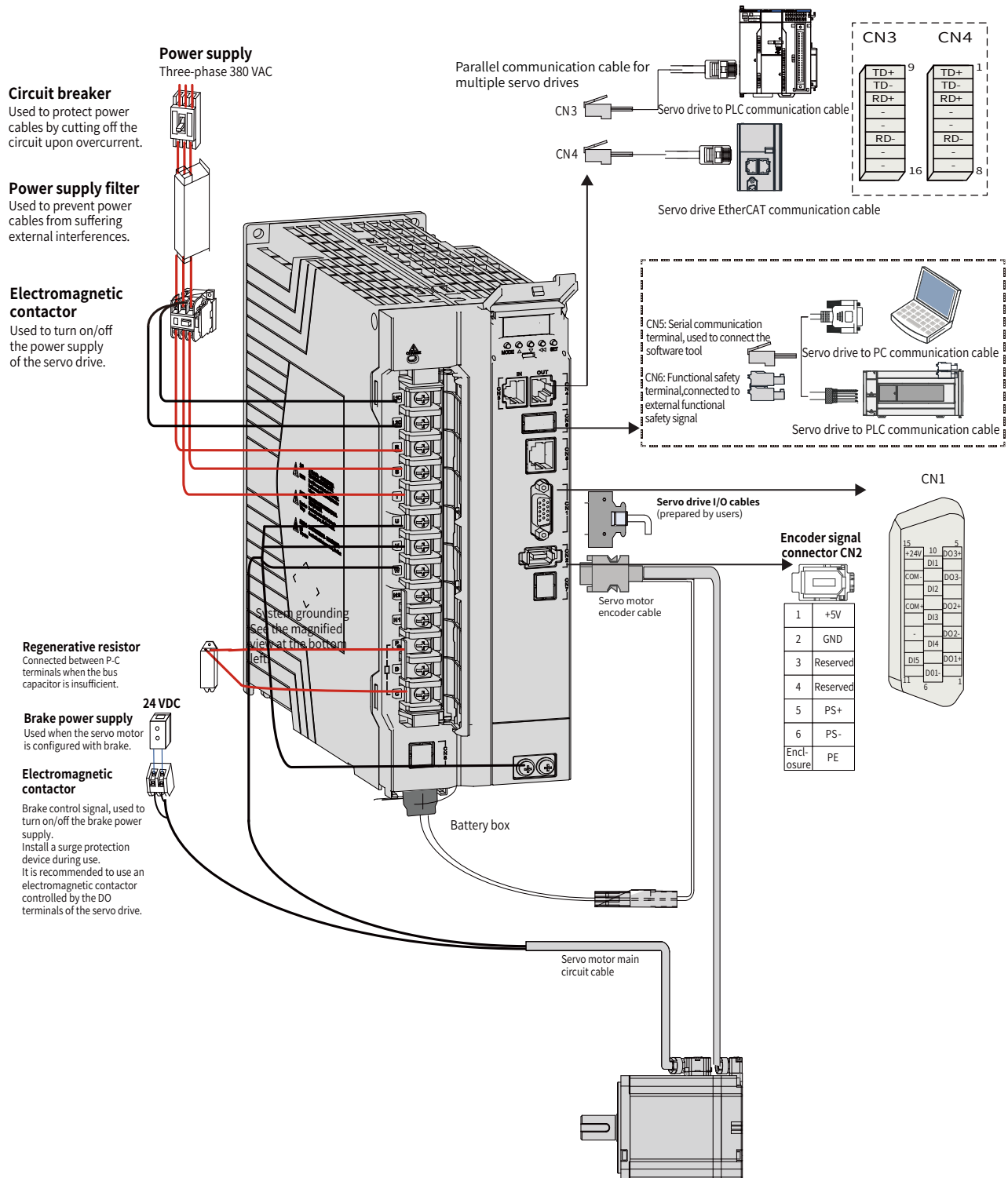

Figure 1-15 Wiring of three-phase 380 V servo systems



The servo drive is directly connected to an industrial power supply without isolation such as a transformer. To prevent damages in case of short circuit, install a fuse or a circuit breaker on the input power supply. To provide protection against electrical shock and/or fire, install a residual current device (RCD).

Do not run or stop the motor by using an electromagnetic contactor. As a high-inductance device, the motor may generate high voltage instantaneously, which may damage the contactor.

Ensure that the power capacity meets specific requirements when connecting an external control power

supply or a 24 VDC power supply, especially when the power supply is used to power up multiple servo drives or brakes. Insufficient power supply will lead to insufficient supply current, resulting in failure of the servo drive or the brake. The brake must be powered by a 24 VDC power supply, and the brake power must match the motor model and meet the brake power requirements.

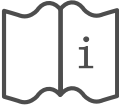
2 Installation

 WARNING	
	Read through the safety instructions in " Safety Instructions ". Failure to comply may result in serious consequences.
 CAUTION	
	<ul style="list-style-type: none"> ◆ Follow the installation directions described in this chapter. Failure to comply may result in device faults or damage. ◆ Do not run a damaged or defective device. Failure to comply will result in physical injuries. ◆ Do not install the device in an environment exposed to water or corrosive objects. Failure to comply will result in device faults. ◆ Do not install the device near flammable gases or combustible materials. Failure to comply will result in a fire or electric shock. ◆ Install the device inside a fire-proof cabinet with electrical protections. Failure to comply may result in a fire. ◆ Reserve specified clearances among the servo drive, the interior surface of the electric cabinet, and other machines. Failure to comply will result in a fire or device faults. ◆ Do not put heavy objects on the device. Failure to comply may result in physical injuries or device damage. ◆ Do not exert large impact force on the device. Failure to comply may result in device damage. ◆ Do not block the air inlet/outlet port of the servo drive or allow unwanted matters to fall into the device. Failure to comply may result in a fire or device faults.

2.1 Installing the Servo Drive

2.1.1 Installation Location

- Install the servo drive into a cabinet free from sunlight and rain.
- Install the servo drive in a place that meets the following requirements:
 - a) Free from corrosive and inflammable gases and combustible materials, such as the hydrogen sulfide, chlorine, ammonia, sulphur gas, chloridize gas, acid, soda, and salt
 - b) Free from high temperature, humidity, dust, and metal powders
 - c) Free from vibration
 - d) Pollution degree: PD2

2.1.2 Environment Conditions

Table 2-1 Installation environment

Item	Description
Ambient temperature	0°C to 55°C (The average load ratio cannot exceed 80% when the ambient temperature is between 45°C to 55°C .)
Ambient humidity	Below 90% RH (without condensation)
Storage temperature	-20°C to +70°C (non-freezing)
Storage humidity	Below 90% RH (without condensation)
Vibration	Below 4.9 m/s ²
Shock	Below 19.6 m/s ²
IP rating	IP20 (except the fan and terminals)
Altitude	Below 1000 m. Derating is required for altitudes above 1000 m. For altitudes above 2000 m, install an isolation transformer besides derating. Derating standard: Derate 1% for every additional 100 m. The maximum altitude is 3000 m.

2.1.3 Dimension Drawings

■ Size A: SV630NS1R6I, SV630NS2R8I

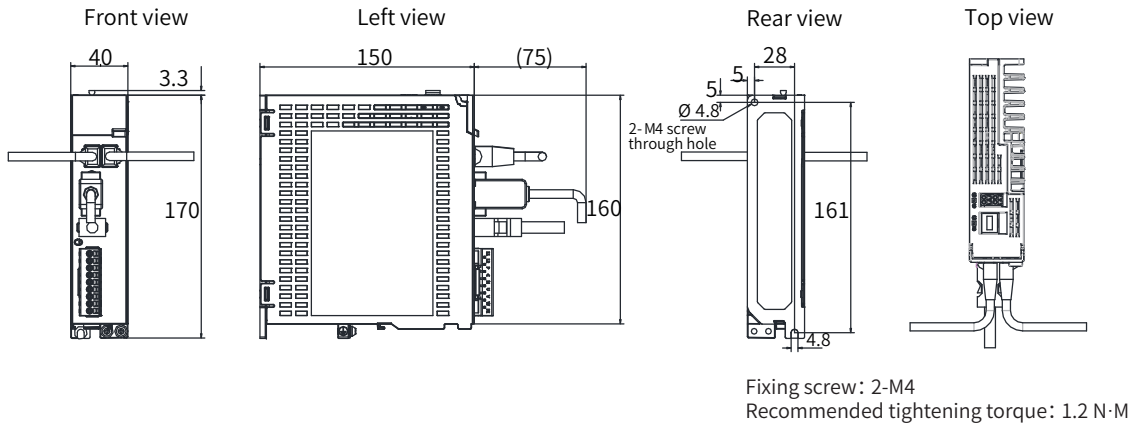

Figure 2-1 Outline dimensions of size A (unit: mm)

The weight of a servo drive in size A is 0.8 kg.

■ Size B: SV630NS5R5I

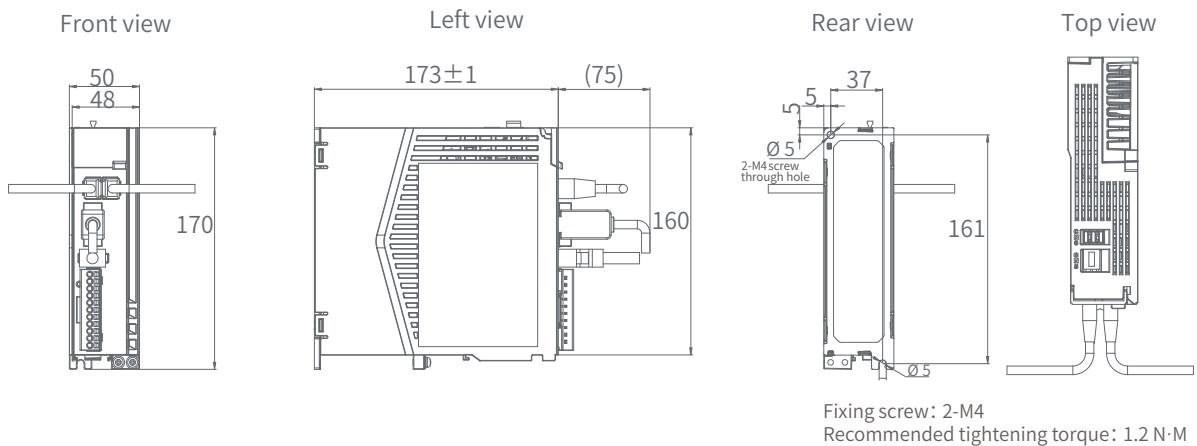

Figure 2-2 Outline dimensions of size B (unit: mm)

The weight of a servo drive in size B is 1.0 kg.

■ Size C: SV630NS7R6I, SV630NT3R5I, SV630NT5R4I

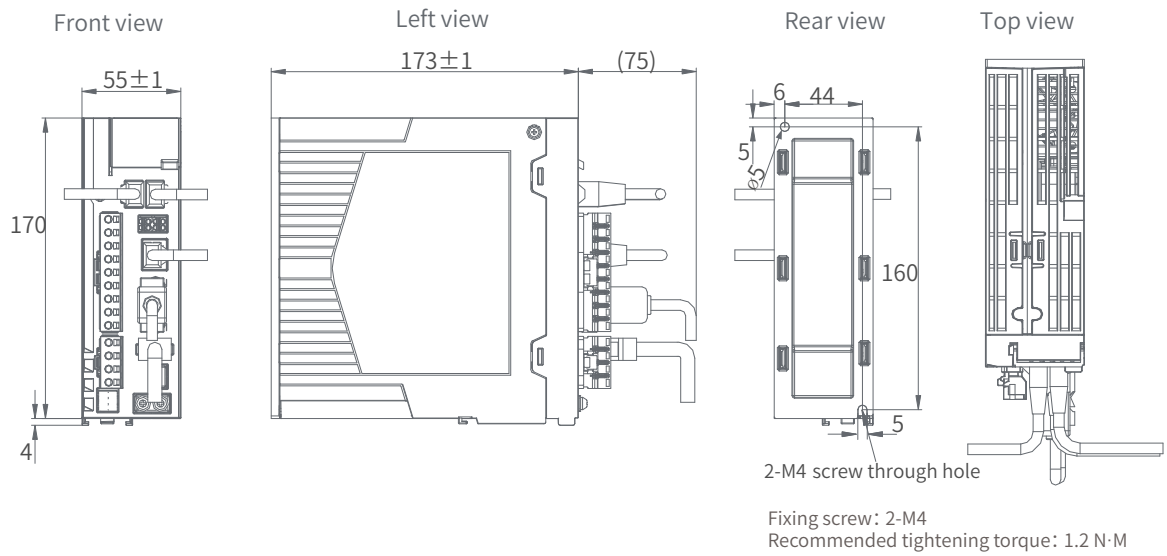

Figure 2-3 Outline dimensions of size C (unit: mm)

The weight of a servo drive in size C is 1.3 kg.

■ Size D: SV630NS012I, SV630NT8R4I, SV630NT012I

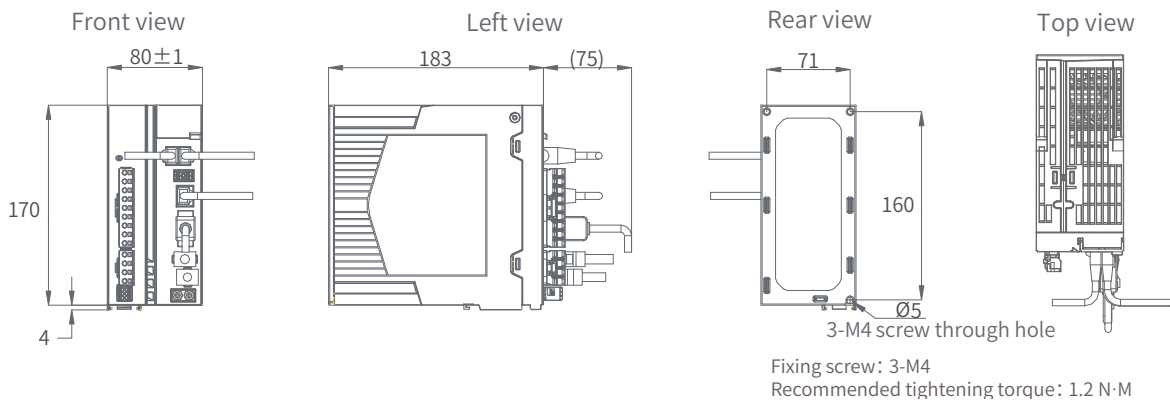

Figure 2-4 Outline dimensions of size D (unit: mm)

The weight of a servo drive in size D is 1.8 kg.

■ Size E: SV630NT017I, SV630NT021I, SV630NT026I

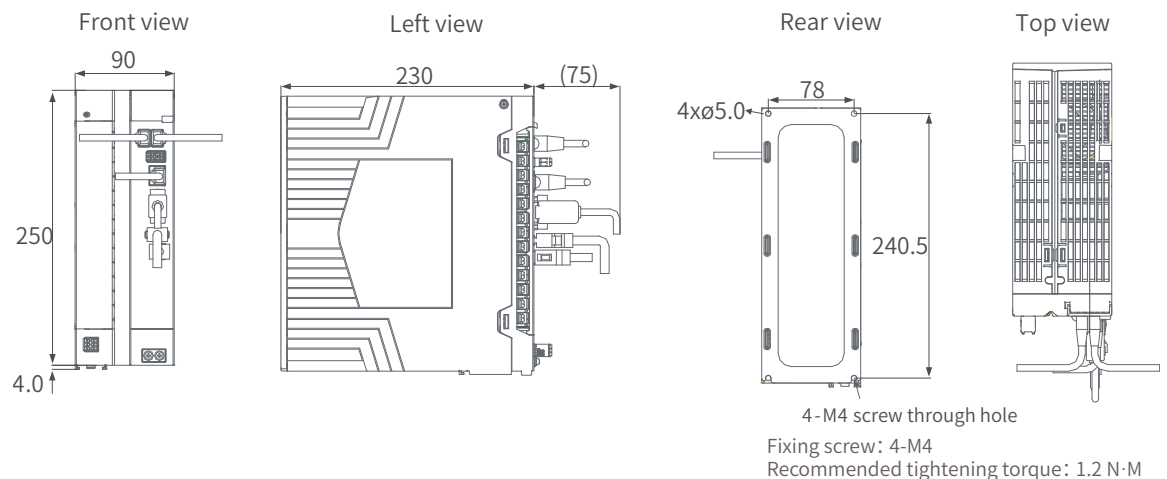

Figure 2-5 Outline dimensions of size E (unit: mm)

The weight of a servo drive in size E is 3.6 kg.

2.1.4 Installation

■ Installation method

Install the servo drive vertically to the wall, with its front side (actual mounting side) facing the operator. Cool the servo drive down with natural convection or a cooling fan. Fix the servo drive securely on the mounting surface through two to four mounting holes (number of mounting holes depends on the capacity of the servo drive).

■ Cooling

As shown in Figure 2-6, reserve sufficient space around the servo drive to ensure proper cooling by the cooling fan or natural convection. Install the cooling fan to the upper part of the servo drive to avoid excessive regional temperature rise and maintain an even temperature inside the electric cabinet.

■ Installation

When installing multiple servo drives side by side, for heat dissipation, reserve a clearance of at least 10 mm between two servo drives and at least 50 mm above and below each servo drive.

For compact installation of servo drives in size A and size B, take the installation tolerance into account and reserve a clearance of at least 1 mm between every two drives. In this case, ensure that the rms load is lower than or equal to 75%.

Install servo drives in size C, size D, and size E side by side without clearance and derating required.

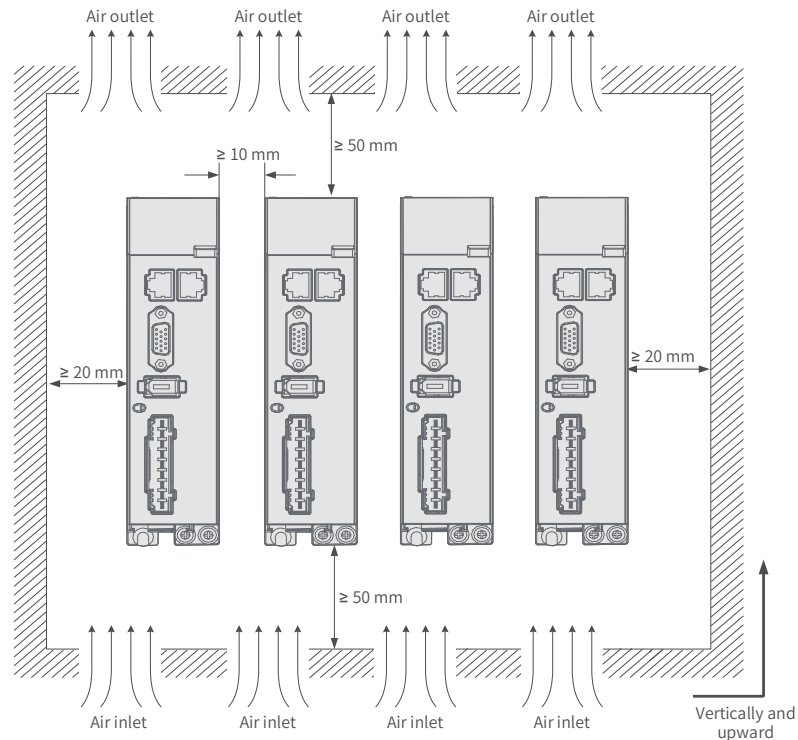

Regular installation

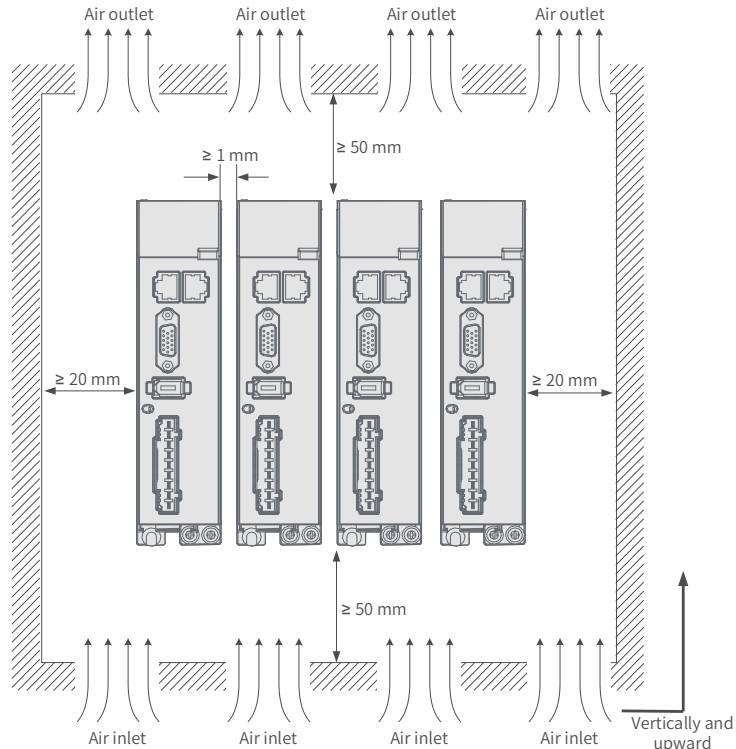

Compact installation

Figure 2-6 Installation of the servo drive

■ Grounding

The grounding terminal must be grounded properly. Failure to comply may cause electric shock or malfunction due to interference.

■ Routing direction

As shown in the following figure, route the servo drive cable downwards to prevent liquids from flowing into the servo drive along the cable.

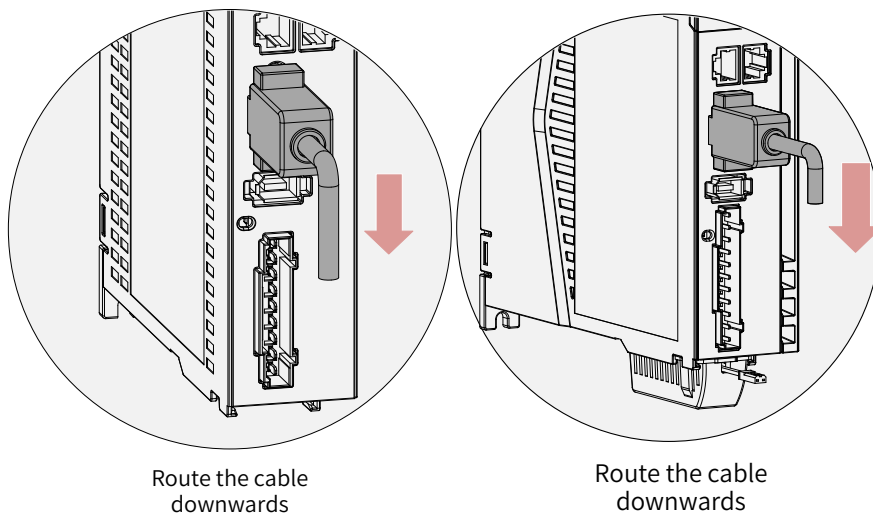

Figure 2-7 Routing direction

■ Dust-proof cover (inserted into the CN5 port by default before delivery)

Insert the dust-proof cover into the unused CN5 port. This is to prevent unwanted objects (such as solids or liquids) from falling into the servo drive and causing faults.

The dust-proof cover is included in the standard configuration. Such dust-proof covers can be purchased separately if required (model: NEX-02-N2B; manufacturer: PINGOOD).

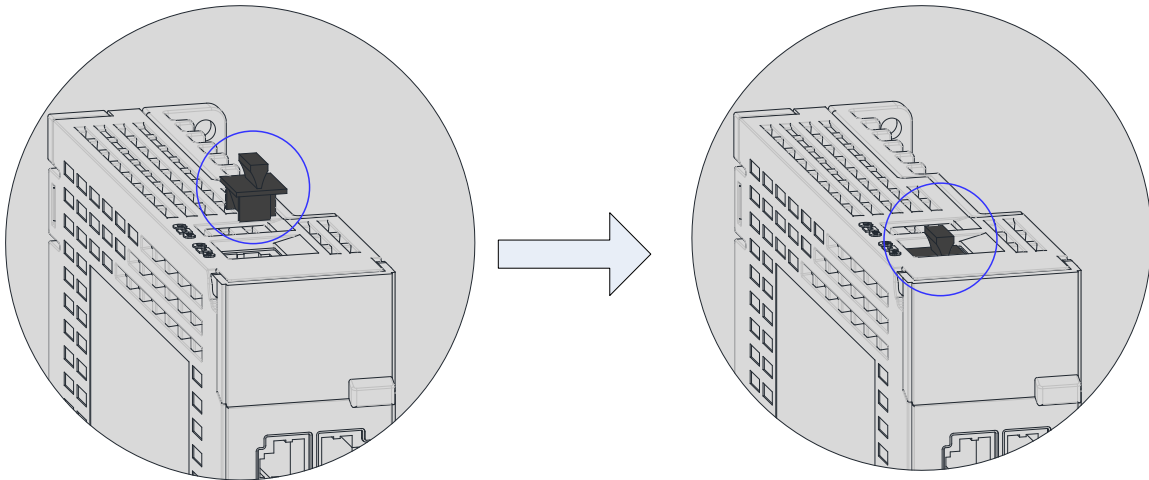

Figure 2-8 Mounting of the dust-proof cover



NOTE

- ◆ The dust-proof cover prevents unwanted objects (such as solids or liquids) from falling into the servo drive and causing faults.
- ◆ The dust-proof cover is delivered along with the servo drive. Keep the dust-proof cover in a proper place.

2.2 Installing the Servo Motor

2.2.1 Installation Location

- Install the servo motor in a place free from corrosive and inflammable gases and combustible materials, such as the hydrogen sulfide, chlorine, ammonia, sulphur gas, chloridize gas, acid, soda, and salt.
- Use the servo motor equipped with an oil seal when the motor is used in a place with grinding fluids, oil mists, iron powders or cuttings.
- Install the servo motor away from heating sources such as a heating stove.
- Do not use the servo motor in an enclosed environment. This may overheat the motor, shortening its service life.

2.2.2 Installation Environment

Table 2-2 Installation environment

Item	Description
Operating temperature	0°C to 40°C (non-freezing)
Operating humidity	20% to 80% RH (without condensation)
Storage temperature	-20°C to +60°C (peak temperature: 80°C for 72 hours)
Storage humidity	20% to 90% RH (without condensation)
Vibration	Below 49 m/s ²
Shock	Below 490 m/s ²

2 Installation

Item	Description
IP rating	IP67 (shaft opening excluded, with power cables and encoder connectors connected properly)
Altitude	Below 1000 m (derating required for altitudes above 1000 m)

2.2.3 Installation Precautions

Table 2-3 Installation precautions

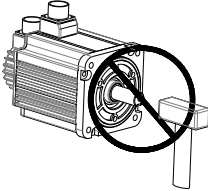
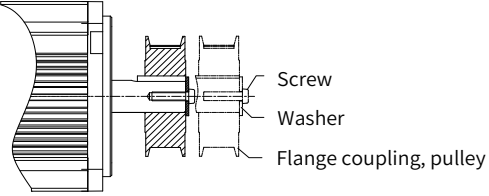
Item	Description
Rust-proof measures	<ul style="list-style-type: none"> ◆ Before installing the servo motor, wipe up the anti-rust agent applied at the motor shaft extension, and then take rust-proof measures.
Encoder	<ul style="list-style-type: none"> ◆ Do not strike the shaft extension during installation. Failure to comply will damage the encoder. 
	<ul style="list-style-type: none"> ◆ Use the screw hole at the shaft end when mounting a pulley to the servo motor shaft with a keyway. ◆ To fit the pulley, insert a double-end screw into the screw hole of the shaft. ◆ Put a washer on the surface of the coupling end, and then use a nut to push the pulley in. ◆ For the servo motor shaft with a keyway, use the screw hole at the shaft end. ◆ For the servo motor shaft without a keyway, use friction coupling or similar methods. ◆ When removing the pulley, use a pulley remover to protect the shaft from suffering severe impact from the load. ◆ To ensure safety, install a protective cover or similar device on the rotary area such as the pulley mounted on the shaft. 

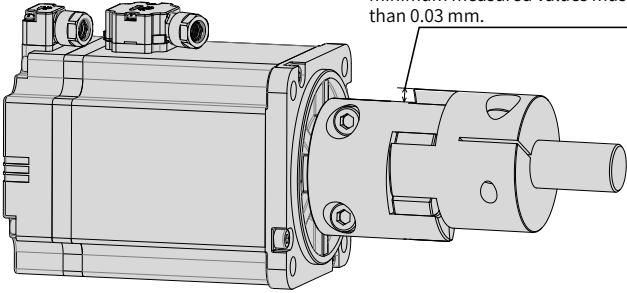
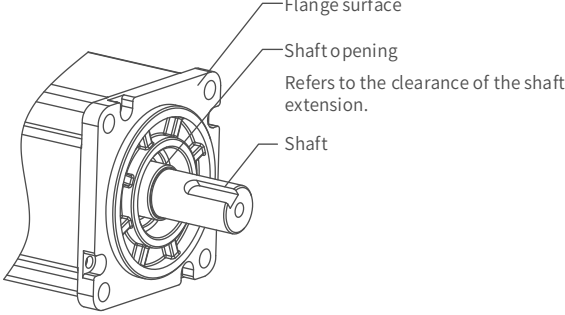
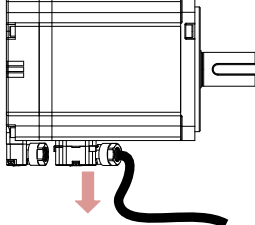
Item	Description
Alignment	<ul style="list-style-type: none"> ◆ When connecting the servo motor to a machine, use a coupling and keep the axes of the motor shaft and the machine shaft in the same line. ◆ Make sure the servo motor fulfills the required alignment precision (as shown in the following figure). Failure to comply will result in vibration or damage to the bearing and the encoder. <div style="text-align: right; margin-top: 10px;"> <p>Measure the distance at four different positions on the circumference. The difference between the maximum and the minimum measured values must be less than 0.03 mm.</p> </div> 
Installation direction	<ul style="list-style-type: none"> ◆ Install the servo motor horizontally or vertically.
Counter-measures against oil and liquid	<ul style="list-style-type: none"> ◆ Do not submerge the motor/cable in water or oil. ◆ When the application location is exposed to water drops, check the IP rating of the servo motor (except the shaft opening) and ensure that the servo motor can be installed in the location. <div style="margin-top: 10px;">  </div> <ul style="list-style-type: none"> ◆ Mount the motor with cable connecting terminal facing downwards if the application location is exposed to liquid. This is to prevent the liquid from flowing into the motor along the cable (as shown in the following figure). <div style="margin-top: 10px;">  </div> <ul style="list-style-type: none"> ◆ In environments where the shaft opening is exposed to oil drops, use a motor with oil sealing. ◆ Observe the following requirements when using a motor with oil sealing: <ol style="list-style-type: none"> 1) Make sure the oil level is lower than the oil sealing lip during use. 2) Avoid oil accumulation on the oil sealing lip when the motor is installed vertically upward.
Stress of cables	<ul style="list-style-type: none"> ◆ Do not bend or apply tension to the cables, especially the signal cables whose core wire is only 0.2 mm or 0.3 mm in thickness. Do not pull the cables too tight during wiring.

Item	Description
Connectors	<p>◆ Observe the following requirements:</p> <ol style="list-style-type: none"> 1) When connecting the connectors, make sure there is no waste or sheet metal inside the connector. 2) Connect the connector to the main circuit cable side of the servo motor first, and ensure the grounding cable of the main circuit is connected properly. If the connector is connected to the encoder cable side first, the encoder may become faulty due to the potential difference between PE terminals. 3) Ensure the pins are correctly arranged during wiring. 4) Do not strike the connector as they are made up of resins. 5) When moving a servo motor with cables connected, hold the servo motor by its main body instead of by the cable. Failure to comply may damage the connector or cable. 6) If flexible cables are used, do not apply stress on the connector during wiring. Failure to comply may damage the connector.

2.2.4 Dimension Drawings

1 Flange size: 40

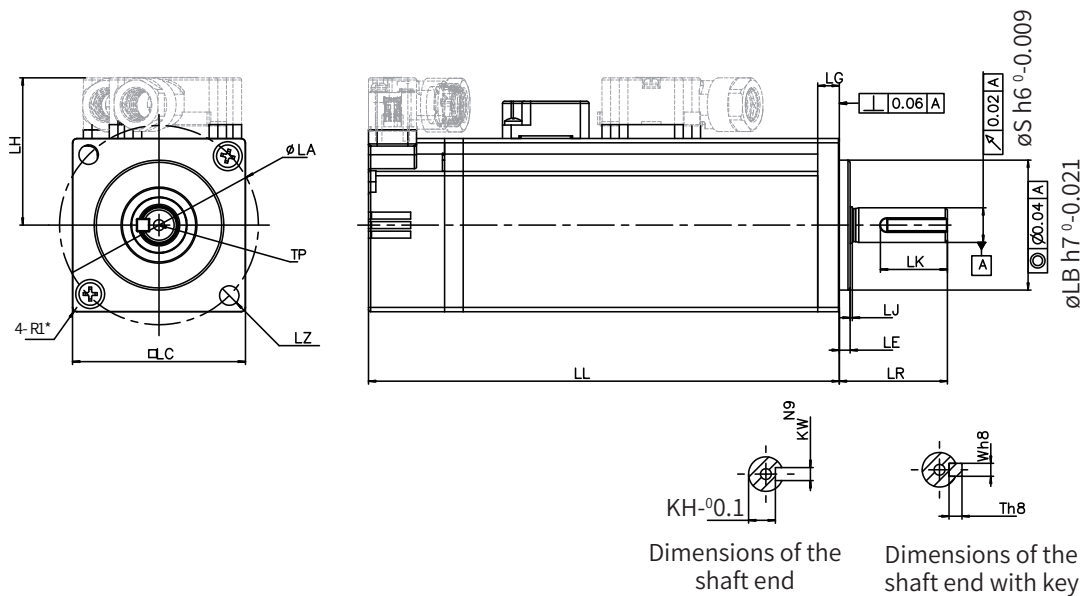

Motor Model	LL	LC	LR	LA	LZ	LH	LG	LE	LJ
MS1H1-05B30CB-****Z(-S)	65 (96)	40	25±0.5	46	2-φ4.5	34	5	2.5±0.5	0.5±0.35
MS1H1-10B30CB-**30Z	77.5 (109)	40	25±0.5	46	2-φ4.5	34	5	2.5±0.5	0.5±0.35
MS1H1-10B30CB-**32Z									
Motor Model	S	LB	TP	LK	KH	KW	W	T	Weight (kg)
MS1H1-05B30CB-****Z(-S)	8	30	M3x6	15.5	6.2	3	3	3	0.39 (0.50)
MS1H1-10B30CB-**30Z	8	30	M3x6	15.5	6.2	3	3	3	0.45 (0.64)
MS1H1-10B30CB-**32Z									

 NOTE	<p>◆ Dimensions in the preceding table are in millimeters.</p> <p>◆ Values in the parentheses "()" are for the servo motor with a holding brake.</p> <p>◆ The tightening torque for terminal screws is 0.19 N·m to 0.21 N·m, violation of which may damage the terminal.</p>
--	--

2 Flange size: 60

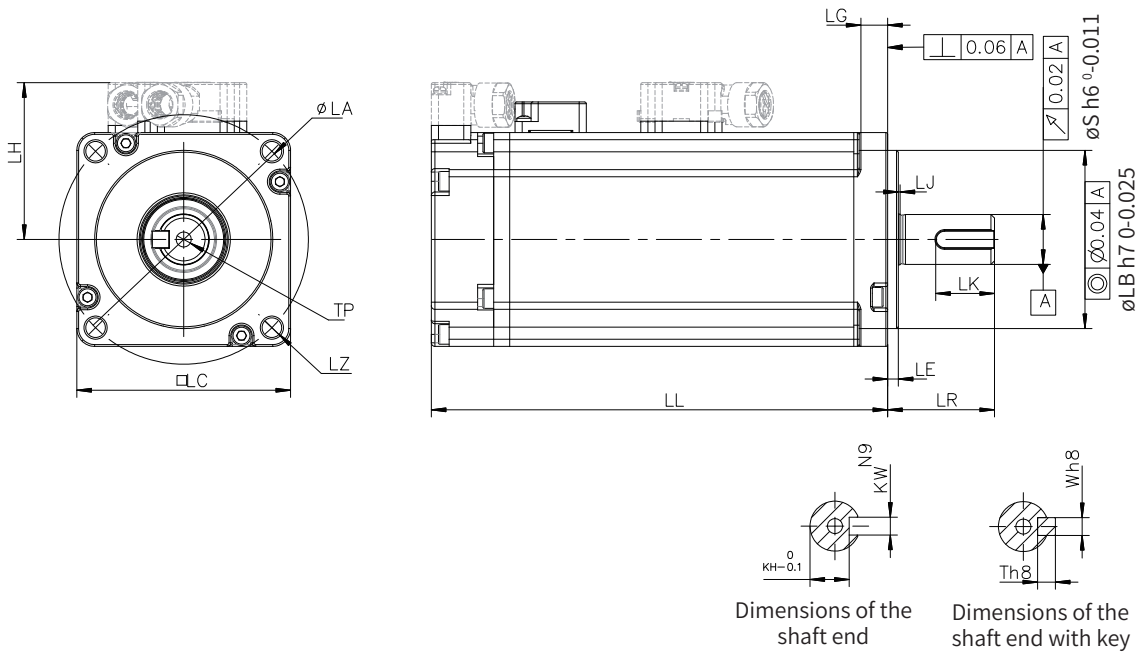

Dimensions of the shaft end

Dimensions of the shaft end with key

Motor Model	LL	LC	LR	LA	LZ	LH	LG	LE	LJ
MS1H1-20B30CB-**31Z	72.5	60	30±0.5	70	4-φ5.5	44	7.5	3±0.5	0.5±0.35
MS1H1-20B30CB-**34Z	100	60	30±0.5	70	4-φ5.5	44	7.5	3±0.5	0.5±0.35
MS1H1-40B30CB-**31Z	91	60	30±0.5	70	4-φ5.5	44	7.5	3±0.5	0.5±0.35
MS1H1-40B30CB-**34Z	119	60	30±0.5	70	4-φ5.5	44	7.5	3±0.5	0.5±0.35
MS1H4-40B30CB-**31Z	105	60	30±0.5	70	4-φ5.5	44	7.5	3±0.5	0.5±0.35
MS1H4-40B30CB-**34Z	128	60	30±0.5	70	4-φ5.5	44	7.5	3±0.5	0.5±0.35
Motor Model	S	LB	TP	LK	KH	KW	W	T	Weight (kg)
MS1H1-20B30CB-**31Z	14	50	M5x8	16.5	11	5	5	5	0.78
MS1H1-20B30CB-**34Z	14	50	M5x8	16.5	11	5	5	5	1.16
MS1H1-40B30CB-**31Z	14	50	M5x8	16.5	11	5	5	5	1.11
MS1H1-40B30CB-**34Z	14	50	M5x8	16.5	11	5	5	5	1.48
MS1H4-40B30CB-**31Z	14	50	M5x8	16.5	11	5	5	5	1.27
MS1H4-40B30CB-**34Z	14	50	M5x8	16.5	11	5	5	5	1.62



- ◆ Dimensions in the preceding table are in millimeters.
- ◆ The tightening torque for terminal screws is 0.19 N·m to 0.21 N·m, violation of which may damage the terminal.

3 Flange size: 80

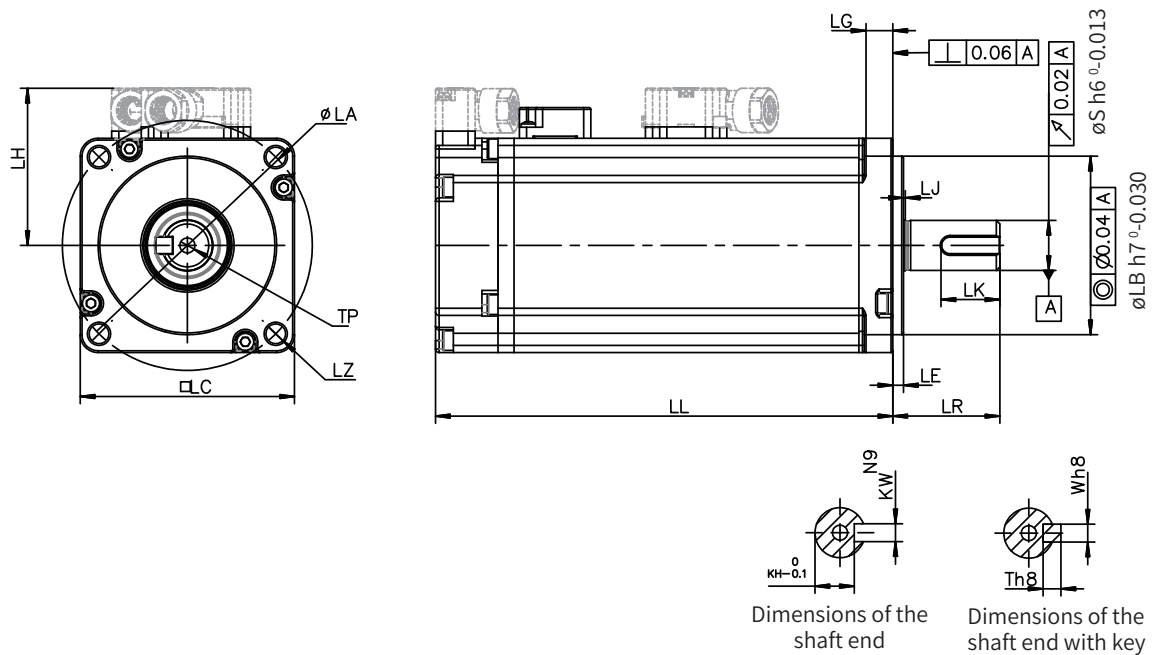

Motor Model	LL	LC	LR	LA	LZ	LH	LG	LE	LJ
MS1H1-55B30CB-***1Z	96.2	80	35±0.5	90	4-φ7	54	7.7	3±0.5	0.5±0.35
MS1H1-75B30CB-**31Z	107	80	35±0.5	90	4-φ7	54	7.7	3±0.5	0.5±0.35
MS1H1-75B30CB-**34Z	140	80	35±0.5	90	4-φ7	54	7.7	3±0.5	0.5±0.35
MS1H1-10C30CB-**31Z(-S)	118.2	80	35±0.5	90	4-φ7	54	7.7	3±0.5	0.5±0.35
MS1H4-75B30CB-**31Z	117.5	80	35±0.5	90	4-φ7	54	7.7	3±0.5	0.5±0.35
MS1H4-75B30CB-**34Z	147.5	80	35±0.5	90	4-φ7	54	7.7	3±0.5	0.5±0.35
Motor Model	S	LB	TP	LK	KH	KW	W	T	Weight (kg)
MS1H1-55B30CB-**31Z	19	70	M6x20	25	15.5	6	6	6	1.85
MS1H1-75B30CB-**31Z	19	70	M6x20	25	15.5	6	6	6	2.18
MS1H1-75B30CB-**34Z	19	70	M6x20	25	15.5	6	6	6	2.82
MS1H1-10C30CB-**31Z(-S)	19	70	M6x20	25	15.5	6	6	6	2.55
MS1H4-75B30CB-**31Z	19	70	M6x20	25	15.5	6	6	6	2.40
MS1H4-75B30CB-**34Z	19	70	M6x20	25	15.5	6	6	6	3.04



- ◆ Dimensions in the preceding table are in millimeters.
- ◆ The tightening torque for terminal screws is 0.19 N·m to 0.21 N·m, violation of which may damage the terminal.

4 Flange size: 100

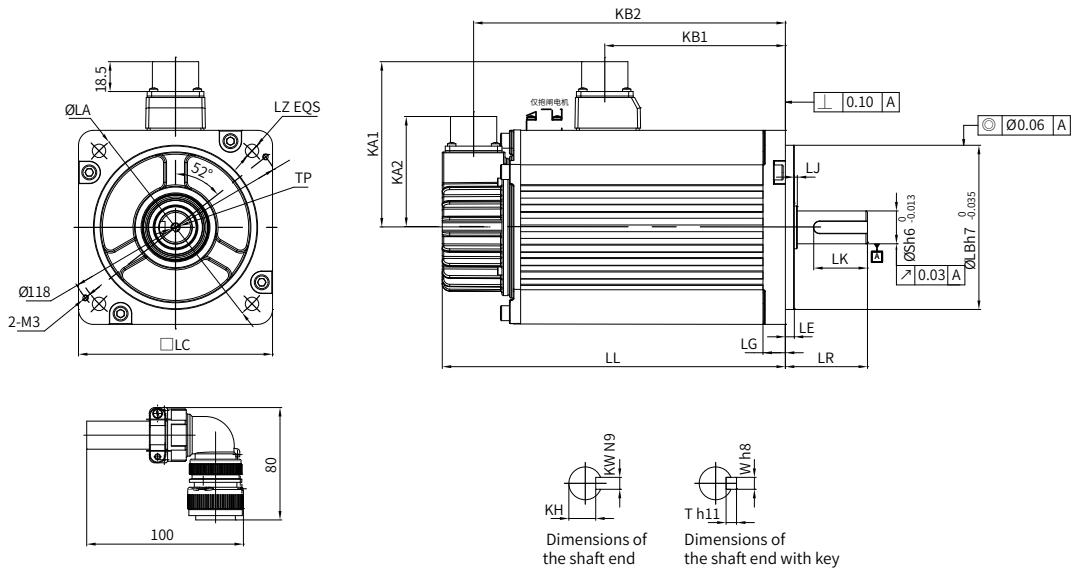

Motor Model	LC	LL	LR	LA	LZ	KA1	KB1	KA2	KB2	LG	
MS1H2-10C30CB-****Z	100	164 (213.5)	45±1	115	4-φ7	88	94.5 (101)	74	143.5 (192.5)	10	
MS1H2-15C30CB-****Z	100	189 (239)	45±1	115	4-φ7	88	119.5 (128)	74	168.5 (219.5)	10	
MS1H2-10C30CD-****Z	100	164 (213.5)	45±1	115	4-φ7	88	94.5 (101)	74	143.5 (192.5)	10	
MS1H2-15C30CD-****Z	100	189 (239)	45±1	115	4-φ7	88	119.5 (128)	74	168.5 (219.5)	10	
MS1H2-20C30CD-****Z(-S4)	100	214 (265)	45±1	115	4-φ7	88	144.5 (153)	74	193.5 (244)	10	
MS1H2-25C30CD-****Z(-S4)	100	240.5 (290)	45±1	115	4-φ7	88	169.5 (178)	74	218.5 (269)	10	
Motor Model	LE	LJ	LB	S	TP	LK	KH	KW	W	T	Weight (kg)
MS1H2-10C30CB-****Z	5±0.3	2.5±0.75	95	24	M8x16	36	20 ⁰ _{-0.2}	8	8	7	5.11 (6.41)
MS1H2-15C30CB-****Z	5±0.3	2.5±0.75	95	24	M8x16	36	20 ⁰ _{-0.2}	8	8	7	6.22 (7.52)
MS1H2-10C30CD-****Z	5±0.3	2.5±0.75	95	24	M8x16	36	20 ⁰ _{-0.2}	8	8	7	5.11 (6.41)
MS1H2-15C30CD-****Z	5±0.3	2.5±0.75	95	24	M8x16	36	20 ⁰ _{-0.2}	8	8	7	6.22 (7.52)
MS1H2-20C30CD-****Z(-S4)	5±0.3	2.5±0.75	95	24	M8x16	36	20 ⁰ _{-0.2}	8	8	7	7.39 (8.7)
MS1H2-25C30CD-****Z(-S4)	5±0.3	2.5±0.75	95	24	M8x16	36	20 ⁰ _{-0.2}	8	8	7	8.55 (9.8)



- ◆ Dimensions in the preceding table are in millimeters.
- ◆ Values in the parentheses "()" are for the servo motor with a holding brake.

5 Flange size: 130

■ Outline drawing of MS1H2

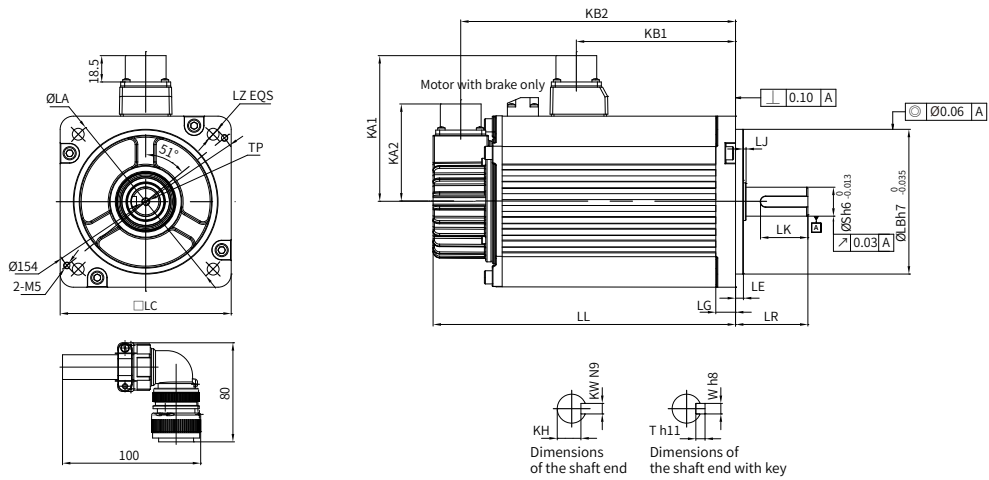

■ Outline drawing of MS1H3

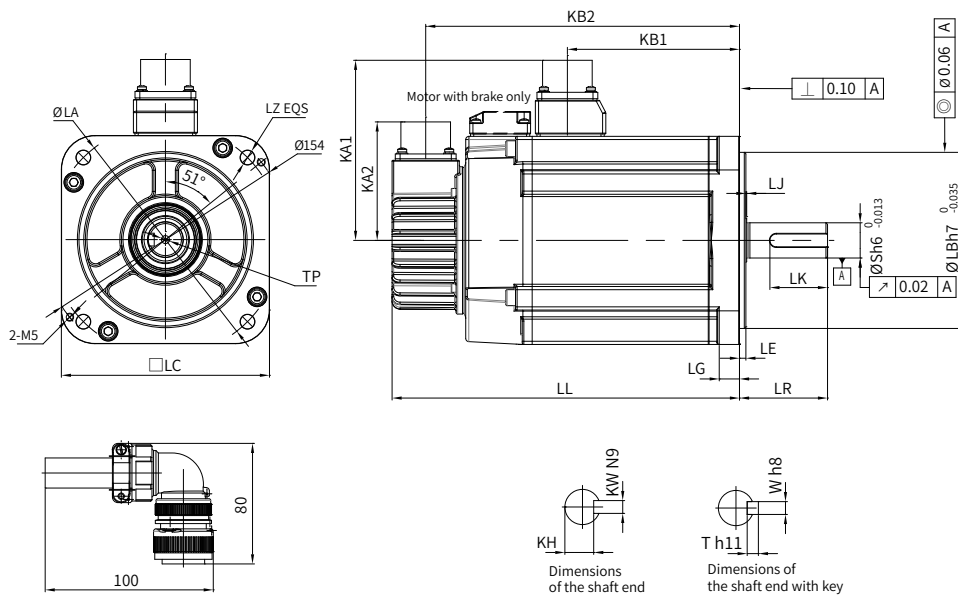

Motor Model	LC	LL	LR	LA	LZ	KA1	KB1	KA2	KB2	LG
MS1H2-30C30CD-****Z(-S4)	130	209.5 (265.5)	63±1	145	4-φ9	103	136 (139)	74	188.5 (244.5)	14
MS1H2-40C30CD-****Z(-S4)	130	252 (308)	63±1	145	4-φ9	103	178.5 (181.5)	74	231 (287)	14
MS1H2-50C30CD-****Z(-S4)	130	294.5 (350.5)	63±1	145	4-φ9	103	221 (224)	74	273.5 (329.5)	14
MS1H3-85B15CB-****Z	130	146 (182)	55±1	145	4-φ9	103	72.5	74	125 (161)	14
MS1H3-13C15CB-****Z	130	163 (199)	55±1	145	4-φ9	103	89.5	74	142 (178)	14
MS1H3-18C15CD-****Z	130	181 (217)	55±1	145	4-φ9	103	107.5	74	160 (196)	14
MS1H3-85B15CD-****Z	130	146 (182)	55±1	145	4-φ9	103	72.5	74	125 (161)	14
MS1H3-13C15CD-****Z	130	163 (199)	55±1	145	4-φ9	103	89.5	74	142 (178)	14

Motor	LE	LJ	LB	S	TP	LK	KH	KW	W	T	Weight (kg)
MS1H2-30C30CD-****Z(-S4)	6±0.3	0.5±0.75	110	28	M8x20	54	24 ⁰ _{-0.2}	8	8	7	10.73 (13.2)
MS1H2-40C30CD-****Z(-S4)	6±0.3	0.5±0.75	110	28	M8x20	54	24 ⁰ _{-0.2}	8	8	7	15.43 (17.9)
MS1H2-50C30CD-****Z(-S4)	6±0.3	0.5±0.75	110	28	M8x20	54	24 ⁰ _{-0.2}	8	8	7	16.2 (18.7)
MS1H3-85B15CB-****Z	4	0.5±0.75	110	22	M6x20	36	18 ⁰ _{-0.2}	8	8	7	7 (8)
MS1H3-13C15CB-****Z	4	0.5±0.75	110	22	M6x20	36	18 ⁰ _{-0.2}	8	8	7	8 (9.5)
MS1H3-18C15CD-****Z	4	0.5±0.75	110	22	M6x20	36	18 ⁰ _{-0.2}	8	8	7	9.5 (11)
MS1H3-85B15CD-****Z	4	0.5±0.75	110	22	M6x20	36	18 ⁰ _{-0.2}	8	8	7	7 (8)
MS1H3-13C15CD-****Z	4	0.5±0.75	110	22	M6x20	36	18 ⁰ _{-0.2}	8	8	7	8 (9.5)



NOTE

- ◆ Dimensions in the preceding table are in millimeters.
- ◆ Values in the parentheses "()" are for the motor with a holding brake.

6 Flange size: 180

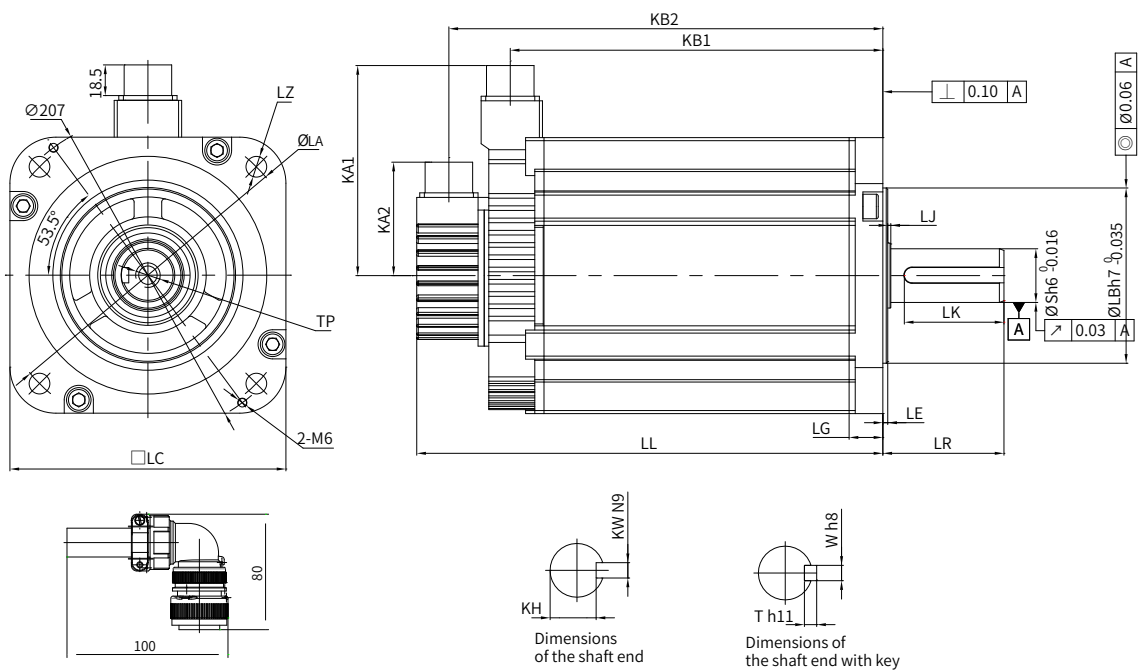

2 Installation









Motor Model	LC	LL	LR	LA	LZ	KA1	KB1	KA2	KB2	LG	
MS1H3-29C15CD-****Z	180	197 (273)	79±1	200	4-φ13.5	138	136 (134)	74	177 (253)	18	
MS1H3-44C15CD-****Z	180	230 (307)	79±1	200	4-φ13.5	138	169 (167)	74	210 (286)	18	
MS1H3-55C15CD-****Z	180	274 (350)	113±1	200	4-φ13.5	138	213 (211)	74	254 (330)	18	
MS1H3-75C15CD-****Z	180	330 (407)	113±1	200	4-φ13.5	138	269 (267)	74	310 (386)	18	
Motor Model	LE	LJ	LB	S	TP	LK	KH	KW	W	T	Weight (kg)
MS1H3-29C15CD-****Z	3.2±0.3	0.3±0.75	114.3	35	M12x25	65	30 ⁰ _{0.2}	10	10	8	15 (25)
MS1H3-44C15CD-****Z	3.2±0.3	0.3±0.75	114.3	35	M12x25	65	30 ⁰ _{0.2}	10	10	8	19.5 (30)
MS1H3-55C15CD-****Z	3.2±0.3	0.3±0.75	114.3	42	M16x32	96	37 ⁰ _{0.2}	12	12	8	28 (38)
MS1H3-75C15CD-****Z	3.2±0.3	0.3±0.75	114.3	42	M16x32	96	37 ⁰ _{0.2}	12	12	8	32 (42)

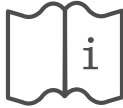

NOTE

- ◆ Dimensions in the preceding table are in millimeters.
- ◆ Values in the parentheses "()" are for the motor with a holding brake.

3 Wiring

 WARNING	
	<ul style="list-style-type: none"> ◆ Read through the safety instructions in "Safety Instructions". Failure to comply may result in serious consequences.
 WARNING	
	<ul style="list-style-type: none"> ◆ Feed the servo drive with power from grounded (TN/TT) systems. Failure to comply may result in electric shock. ◆ Between the input power supply and the main circuit power supply of the servo drive (L1 and L2 for single-phase drives; L1, L2, and L3 for three-phase drives), connect an electromagnetic contactor to form an architecture that allows independent power cutoff on the servo drive power side. This is to prevent fire accidents caused by continuous large current upon fault. ◆ Ensure the input power supply of the servo drive is within the specified voltage range. Otherwise, the servo drive may become faulty. ◆ Do not connect output terminals U, V, and W of the servo drive to a three-phase power supply. Failure to comply may cause physical injuries or fire accidents. ◆ Do not connect the motor connecting terminals U, V, and W to a mains frequency power supply. Failure to comply may cause physical injuries or fire accidents. ◆ Use the ALM (fault signal) to cut off the main circuit power supply. When the braking transistor is faulty, the regenerative resistor may be overheated, leading to a fire accident.
 WARNING	
	<ul style="list-style-type: none"> ◆ Connect the PE terminal of the servo drive to that of the control cabinet. Failure to comply may cause electric shock. ◆ Ensure the entire system is grounded. Otherwise, the servo drive may malfunction.
 WARNING	
  15min	<ul style="list-style-type: none"> ◆ After cutting off the power supply, wait for at least 15 minutes before further operations. This is because residual voltage is still present in the internal capacitor after power-off. Failure to comply may result in electric shock.



	<ul style="list-style-type: none"> ◆ The specifications and installation method of external cables must comply with applicable local regulations. ◆ Abide by the following requirements when applying the servo drive on a vertical axis. <ol style="list-style-type: none"> 1) Set the safety device properly to prevent the workpiece from falling under such status as warning and overtravel. 2) Ensure the polarity of the 24 V power supply is correct. Otherwise, the shaft may fall and cause physical injuries or damage to the servo drive. ◆ Abide by the following requirements when wiring the power supply and the main circuit: <ol style="list-style-type: none"> 1) When the main circuit terminal is a connector, remove the connector from the servo drive before wiring. 2) Insert only one cable to one terminal of the connector. 3) Insert the cable with enough care to prevent the conductor burrs from being short circuited to the neighboring cable. 4) Insulate the connecting part of the power terminals to prevent electric shock. 5) Do not connect a 220 V servo drive to a 380 V power supply directly. 6) Install safety devices such as a circuit breaker to prevent fire accidents caused by short-circuit in external circuits. 7) Cut off the main circuit power supply and switch from S-ON to S-OFF after a warning signal is detected. ◆ Connect the servo drive to the motor directly. Do not use an electromagnetic contactor during wiring. Failure to comply may cause faults. ◆ Do not put heavy objects on the cables or pull the cable with large force. Otherwise, electric shock may occur due to cable damage. ◆ When connecting DO terminals to relays, ensure the polarity of the flywheel diode is connected correctly. Otherwise, the servo drive will be damaged and the signal output may be abnormal. ◆ Reserve a clearance of at least 30 cm between main circuit cables and I/O signal/encoder cables. Failure to comply may cause malfunction of the servo drive. ◆ Use twisted pair cables or multi-core shielded twisted cables as the I/O signal/encoder cables. Failure to comply may cause malfunction of the servo drive. ◆ The maximum wiring length of the I/O signal cable and the encoder cable is 3 m and 20 m respectively. ◆ Use a noise filter to reduce the electromagnetic interference on electronic devices surrounding the servo drive. ◆ To prevent damage to the servo drive, take proper shielding measures when the servo drive is used in the following application locations: <ol style="list-style-type: none"> 1) Locations suffering from interferences caused by static electricity 2) Locations suffering from strong electric field or strong magnetic field 3) Locations with radioactive rays
--	---

3.1 Terminal Pin Layout

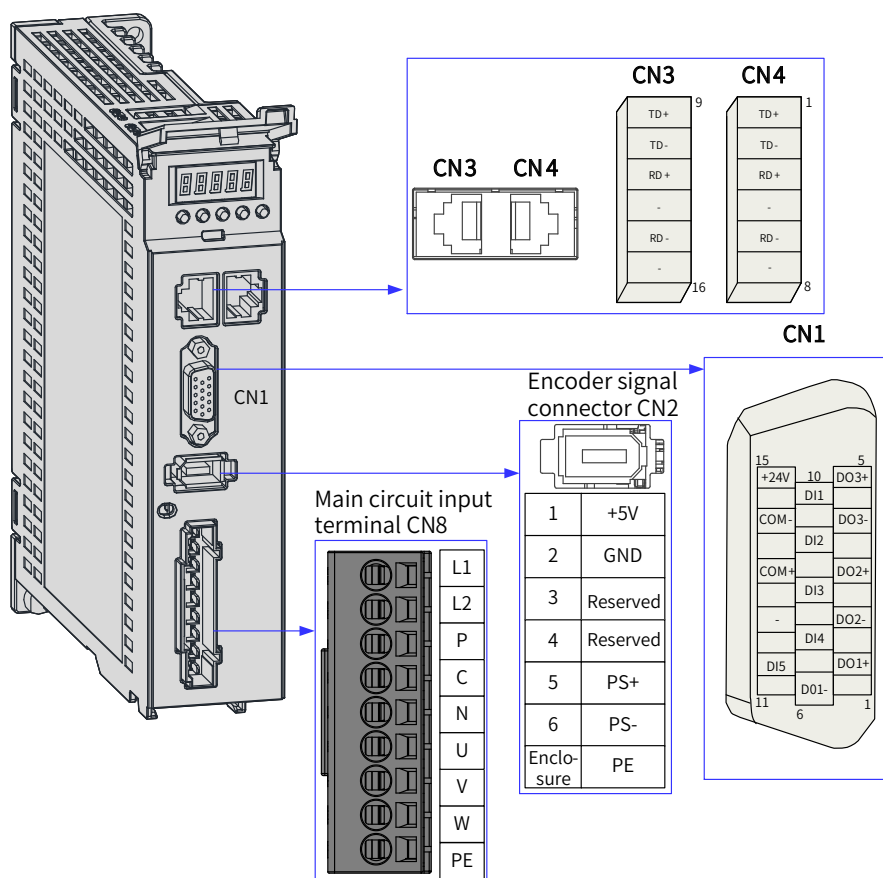

Figure 3-1 Terminal pin layout of servo drives in size A



NOTE

◆ The preceding figure shows the pin layout of the servo drive terminals.

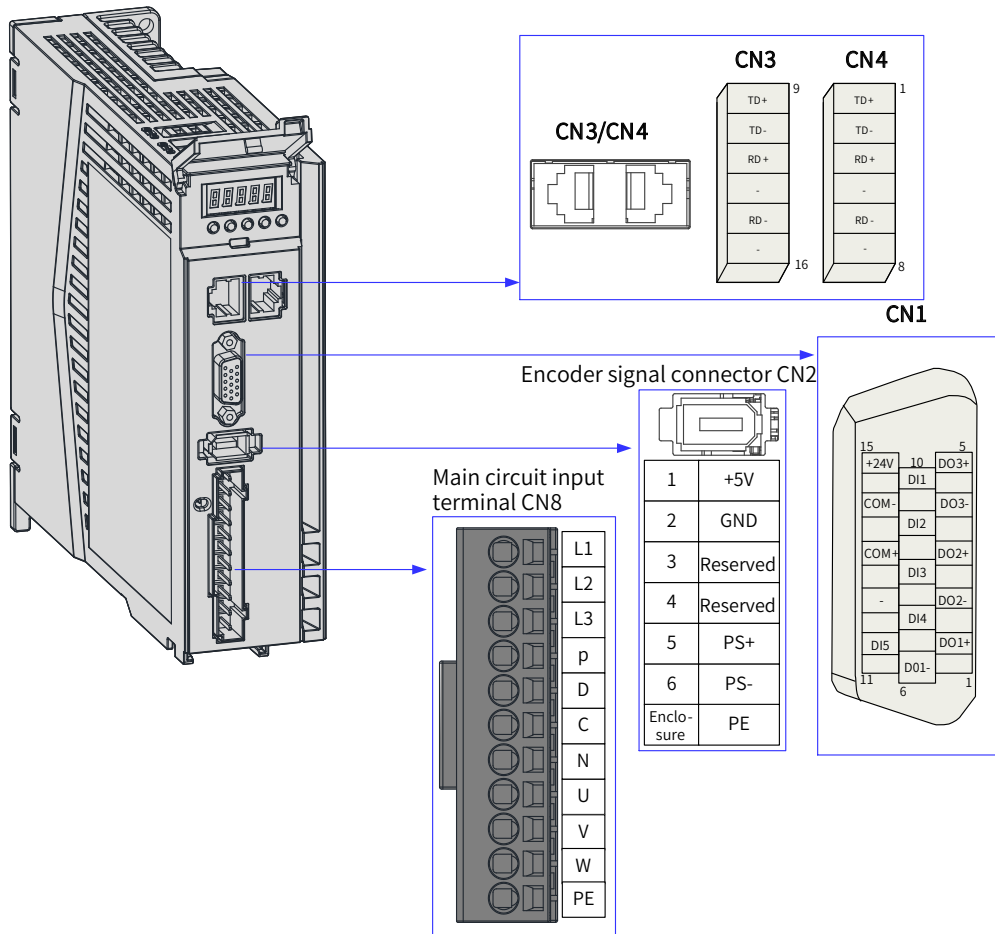

Figure 3-2 Terminal pin layout of servo drives in size B



◆ The preceding figure shows the pin layout of the servo drive terminals.

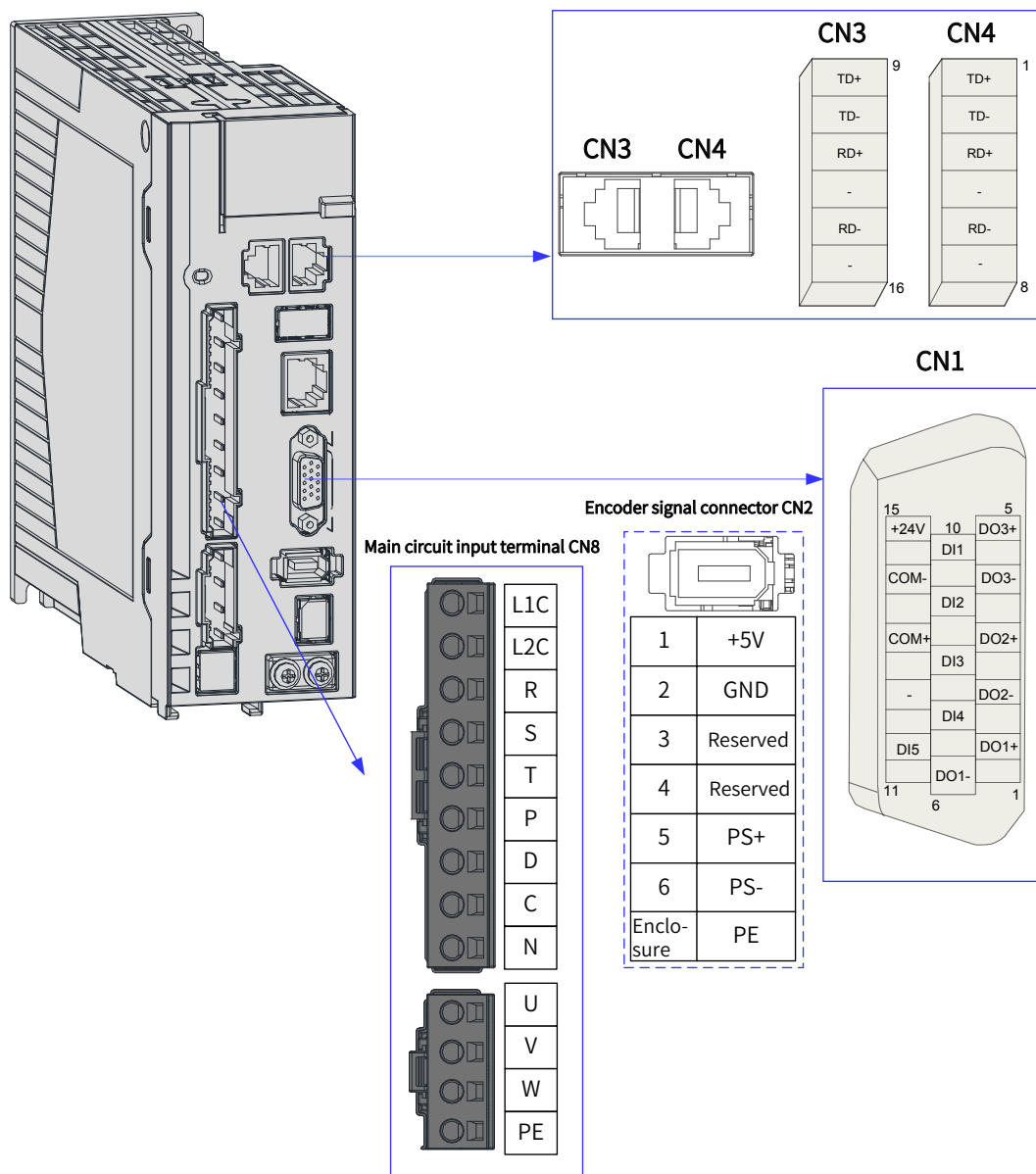

Figure 3-3 Terminal pin layout of servo drives in size C and size D



NOTE

◆ The preceding figure shows the pin layout of the servo drive terminals.

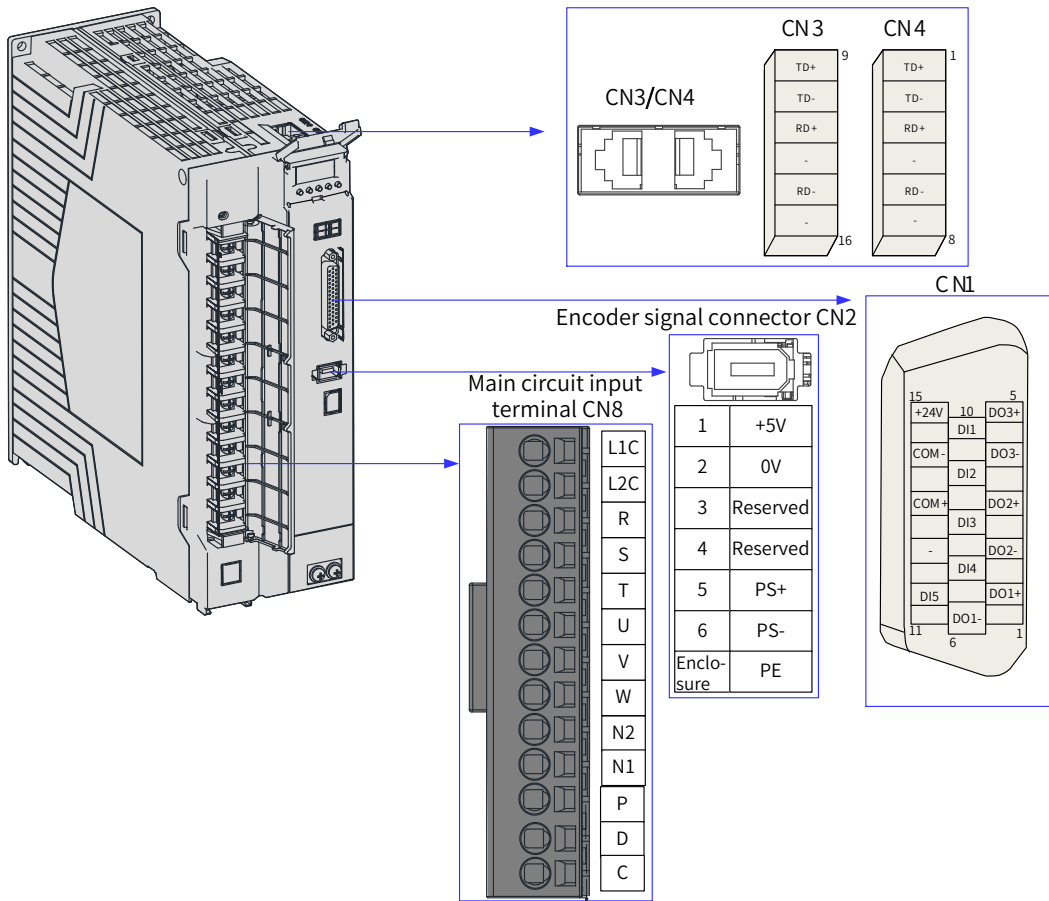

Figure 3-4 Terminal pin layout of servo drives in size E



◆ The preceding figure shows the pin layout of the servo drive terminals.

3.2 Wiring of the Main Circuit

3.2.1 Main Circuit Terminals

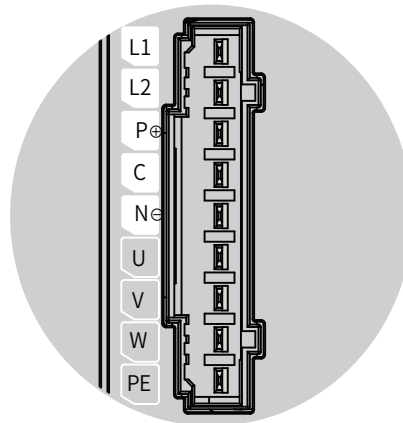

Figure 3-5 Main circuit terminal pin layout of servo drives in size A

Table 3-1 Names and functions of main circuit terminals of servo drives in size A

No.	Name	Description
1	L1, L2 (power input terminals)	See the nameplate for the rated voltage of the power supply.
2	P ⊕ , N ⊖ (DC bus terminals)	Used as the common DC bus for multiple servo drives.
	P ⊕ , C (terminals for connecting external regenerative resistor)	When an external regenerative resistor is needed, connect it between terminals P ⊕ and C.
3	U, V, W (terminals for connecting the servo motor)	Connected to U, V, and W phases of the servo motor.
4	PE (grounding terminal)	Connected to the power supply ground and the motor grounding terminal.

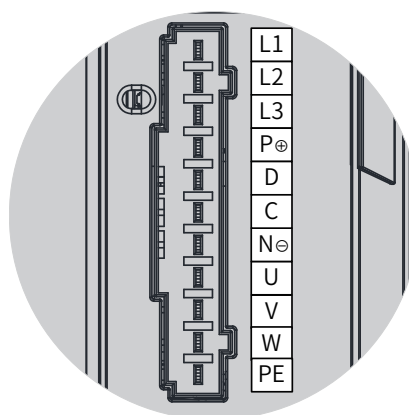

Figure 3-6 Main circuit terminal pin layout of servo drives in size B

Table 3-2 Names and functions of main circuit terminals of servo drives in size B

No.	Name	Description
1	L1, L2, L3 (Power input terminals)	See the nameplate for the rated voltage of the power supply. Note: ◆ S5R5 (750 W) servo drives: Single-phase 220 V power input, with 220 V power supply connected to L1 and L2
2	P ⊕ , N ⊖ (DC bus terminals)	Used as the common DC bus for multiple servo drives.
	P ⊕ , D, C (Terminals for connecting external regenerative resistor)	When an external regenerative resistor is needed, connect it between terminals P ⊕ and C. Servo drives in size B are equipped with a built-in regenerative resistor. In this case, terminals P and D are shorted by default.
3	U, V, W (Servo motor connecting terminals)	Connected to U, V, and W phases of the servo motor.
4	PE (Grounding terminal)	Connected to the power supply ground and the motor grounding terminal.

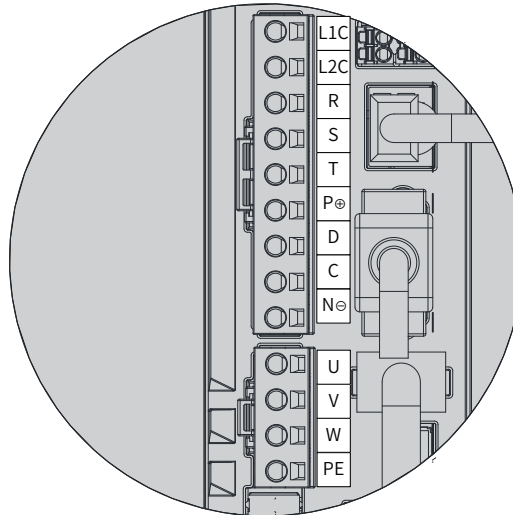

Figure 3-7 Main circuit terminal pin layout of servo drives in size C and size D

Table 3-3 Names and functions of main circuit terminals of servo drives in size C and size D

No.	Name	Description
1	L1C, L2C (control circuit power input terminals)	See the nameplate for the rated voltage of the power supply.
2	R, S, T (main circuit power input terminals)	See the nameplate for the rated voltage of the power supply.
3	P ⊕ , N ⊖ (DC bus terminals)	Used as the common bus terminal for multiple servo drives.
	P ⊕ , D, C (terminals for connecting external regenerative resistor)	When an external regenerative resistor is needed, connect it between terminals P ⊕ and C. Servo drives in sizes C and D are equipped with a built-in regenerative resistor. In this case, terminals P and D are shorted by default.
4	U, V, W (terminals for connecting the servo motor)	Connected to the U, V and W phases of the servo motor.
5	PE (grounding terminal)	Connected to the power supply ground and the motor grounding terminal.

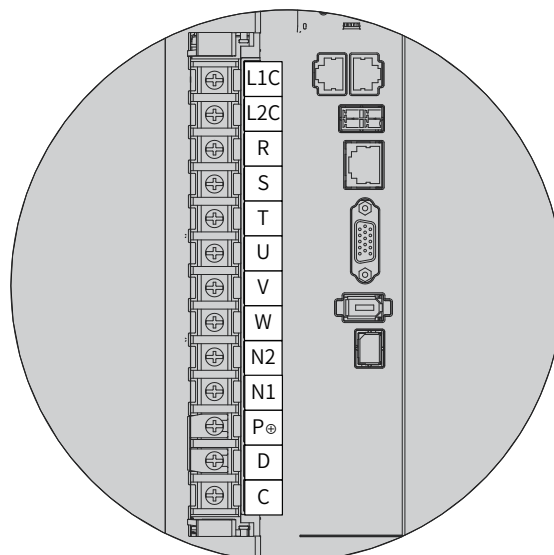

Figure 3-8 Main circuit terminal pin layout of servo drives in size E

Table 3-4 Names and functions of main circuit terminals of servo drives in size E

No.	Component Name	Description
1	L1C, L2C (control circuit power input terminals)	See the nameplate for the rated voltage of the power supply.
2	R, S, T (main circuit power input terminals)	See the nameplate for the rated voltage of the power supply.
3	U, V, W (terminals for connecting the servo motor)	Connected to the U, V and W phases of the servo motor.
4	N2, N1 (terminals for connecting external reactor)	Terminals N1 and N2 are jumpered by default. Remove the jumper first if you need to install an external DC reactor between N1 and N2.
5	P ⊕, D, C (terminals for connecting external regenerative resistor)	When an external regenerative resistor is needed, connect it between terminals P ⊕ and C. Servo drives in size E are equipped with a built-in regenerative resistor. In this case, terminals P and D are shorted by default.

3.2.2 Wiring Example of the Regenerative Resistor

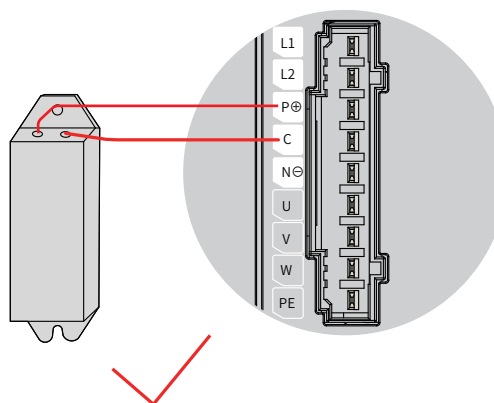



Figure 3-9 Connection of the external regenerative resistor

 WARNING	
	<p>Observe the following requirements when connecting the external regenerative resistor:</p> <ul style="list-style-type: none"> ◆ Remove the jumper between P and D before connecting the external regenerative resistor. Failure to comply will cause overcurrent and damage the braking transistor. ◆ Do not connect the external regenerative resistor to the positive/negative pole of the bus directly. Failure to comply will damage the servo drive and cause a fire. ◆ Do not select any resistor with a resistance lower than the minimum permissible value. Failure to comply will result in E201 (Overcurrent) or damage the servo drive. ◆ Make sure parameters H02-25 (Regenerative resistor setting), H02-26 (Power of external regenerative resistor) and H02-27 (Resistance of external regenerative resistor) are set properly before use. ◆ Install the external regenerative resistor on incombustible objects such as a metal.

3.2.3 Specifications of Main Circuit Cables

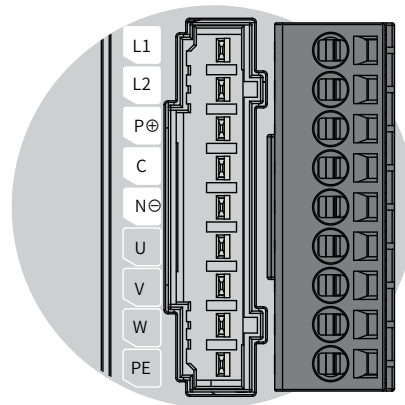

Figure 3-10 Main circuit terminal block of the servo drive

Table 3-5 Input/Output current specifications of SV630N series servo drives

Servo Drive Model SV630N****I		Rated Input Current (A)	Rated Output Current (A)	Maximum Output Current (A)
Size A	S1R6	2.3	1.6	5.8
	S2R8	4.0	2.8	10.1
Size B	S5R5	7.9 (single-phase)	5.5	16.9
Size C	S7R6	5.1	7.6	23
	T3R5	2.4	3.5	11
	T5R4	3.6	5.4	14
Size D	S012	8.0	11.6	32
	T8R4	5.6	8.4	20
	T012	8.0	11.9	29.75
Size E	T017	12.0	16.5	41.25
	T021	16.0	20.8	52.12
	T026	21.0	25.7	64.25

Table 3-6 Recommended main circuit cables

Servo Drive Model SV630N****		L1C, L2C		R, S, T		P _⊕ , C		U, V, W		PE	
		AWG	mm ²	AWG	mm ²	AWG	mm ²	AWG	mm ²	AWG	mm ²
Single-phase 220 V											
Size A	S1R6I	2x0.75	18	2x0.75	18	2x0.75	18	3x0.5	20	0.5	20
	S2R8I	2x0.75	18	2x0.75	18	2x0.75	18	3x0.5	20	0.5	20
Size B	S5R5I	2x0.75	18	2x0.75	18	2x0.75	18	3x0.5	20	0.5	20
Size C	S7R6I	3x0.75	18	3x0.75	18	3x0.75	18	Matching MS1H1-10C30CB motors: 3x0.5	20	Matching MS1H1-10C30CB motors: 0.5	20
								Matching MS1H2-10C30CB/MS1H3-85B15CB motors: 3x1.5	16	Matching MS1H2-10C30CB/MS1H3-85B15CB motors: 1.5	16
Size D	S012I	3x0.75	16	3x0.75	16	3x0.75	16	3x1.5	16	1.5	16

Servo Drive Model SV630N****		L1C, L2C		R, S, T		P _⊕ , C		U, V, W		PE	
		AWG	mm ²	AWG	mm ²	AWG	mm ²	AWG	mm ²	AWG	mm ²
Three-phase 220 V											
Size C	S7R6I	2x0.75	18	3x0.75	18	2x0.75	18	Matching MS1H1-10C30CB motors: 3x0.5	20	Matching MS1H1-10C30CB motors: 0.5	20
								Matching MS1H2-10C30CB/MS1H3-85B15CB motors: 3 x 1.5	16	Matching MS1H2-10C30CB/MS1H3-85B15CB motors: 1.5	16
Size D	S012I	2x0.75	18	3x1.5	16	2x1.5	16	3x1.5	16	1.5	16
Three-phase 380 V											
Size C	T3R5I	2x0.75	18	3x0.75	18	2x0.75	18	3x1.5	16	1.5	16
	T5R4I	2x0.75	18	3x0.75	18	2x0.75	18	3x1.5	16	1.5	16
Size D	T8R4I	2x0.75	18	3x0.75	18	2x1.5	16	3x1.5	16	1.5	16
	T012I	2x0.75	18	3x1.5	16	2x1.5	16	3x1.5	16	1.5	16
Size E	T017I	2x0.75	18	3x1.5	16	2x4.0	12	Matching MS1H2-40C30CD/MS1H2-50C30CD motors: 3x2.5	14	2.50	14
								Matching MS1H3-44C15CD motors: 3x4.0	12	4.00	12
	T021I	2x0.75	18	3x2.5	14	2x4.0	12	3x4.0	12	4.00	12
	T026I	2x0.75	18	3x4.0	12	2x4.0	12	3x4.0	12	4.00	12

See ["3.2.5 Precautions for Main Circuit Wiring"](#) for details.

Table 3-7 Recommended grounding cable lug of the main circuit

Servo Drive Model SV630N****I		PE
Size A	SV630NS1R6I	TVR 2-4
	SV630NS2R8I	TVR 2-4
Size B	SV630NS5R5I	TVR 2-4
Size C	SV630NS7R6I	TVR 2-4
	SV630NT3R5I	TVR 2-4
	SV630NT5R4I	TVR 2-4
Size D	SV630NS012I	TVR 2-4
	SV630NT8R4I	TVR 2-4
	SV630NT012I	TVR 2-4
Size E	SV630NT017I	TVR 2-4
	SV630NT021I	TVR 2-4
	SV630NT026I	TVR 2-4

Reference data for recommended cable lugs (Manufacturer: Suzhou Yuanli Metal Enterprise Co., Ltd)

Table 3-8 Dimensions and outline drawing of the grounding cable lug

Cable Lug Model		D (mm)	d2 (mm)	B (mm)	Outline Drawing
TVR	2-4	4.5	4.3	8.5	

Use the following types of cables for the main circuit.

Table 3-9 Recommended main circuit cables

Cable Type		Allowable Temperature (°C)
Model	Name	
PVC	General PVC cable	-
IV	PVC cable with a rated voltage of 600 V	60
HIV	Special PVC cable with heat-resistance capacity	75

For UVW cables, the relation between AWG specification and the allowable current is shown in the following table.

Note that the values listed in the table cannot be exceeded during use.

Table 3-10 Specifications for UVW cables

AWG Specification	Nominal Cross Sectional Area (mm ²)	Allowable Current in Different Ambient Temperatures (A)		
		30°C	40°C	50°C
20	0.519	8	7	6
19	0.653	9	8	7
18	0.823	13	11	9
16	1.31	18	15	12
14	2.08	26	23	20
12	3.31	32	28	26
10	5.26	48	43	38
8	8.37	70	65	55
6	13.3	95	85	75

3.2.4 Wiring Example of the Power Supply

- Single-phase 220 V models: SV630NS1R6I, SV630NS2R8I, SV630NS5R5I, SV630NS7R6I and SV630NS012

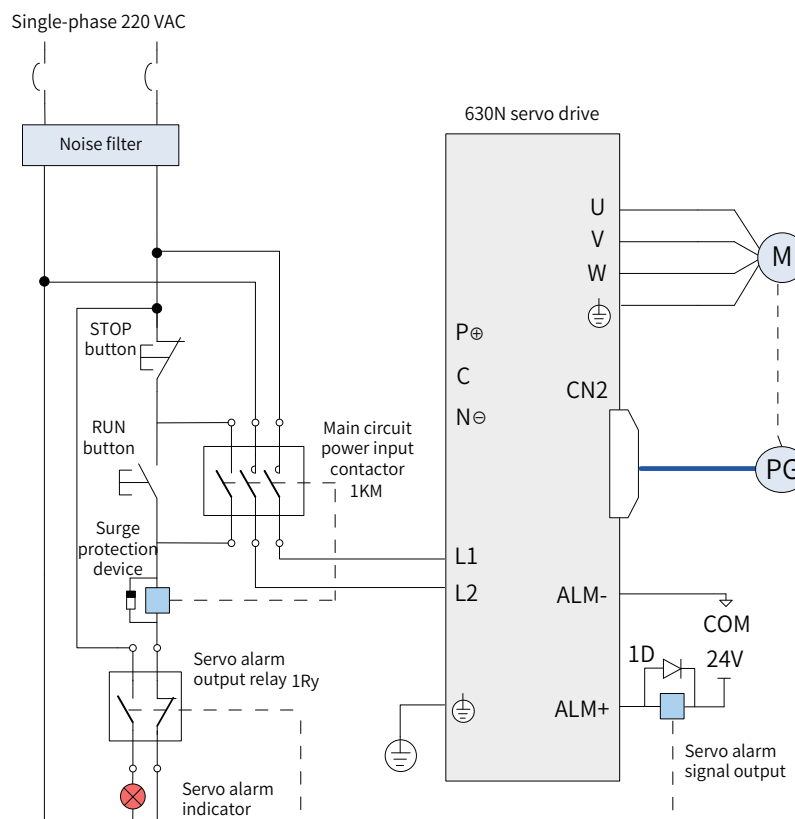
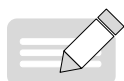

Figure 3-11 Main circuit wiring example of single-phase 220 V models



NOTE

- ◆ 1KM: Electromagnetic contactor; 1Ry: Relay; 1D: Flywheel diode
- ◆ DO is set as alarm output (ALM+/-). When the servo drive alarms, the power supply will be cut off automatically. SV630NS1R6 and SV630NS2R8 are not configured with a built-in regenerative resistor. Connect an external regenerative resistor between terminals P ⊕ and C if required.

■ Single-phase/Three-phase 220 V models: SV630NS7R6I and SV630NS012I

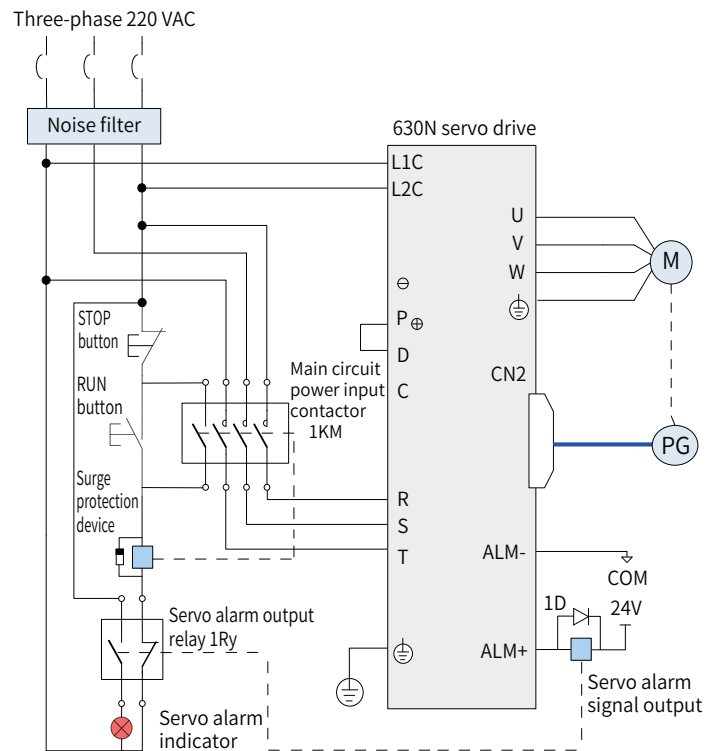

Figure 3-12 Main circuit wiring example of three-phase 220 V models



- ◆ 1KM: Electromagnetic contactor; 1Ry: Relay; 1D: Flywheel diode
- ◆ DO is set as alarm output (ALM+/-). When the servo drive alarms, the power supply will be cut off automatically and the alarm indicator will be turned on.

- Three-phase 380 V models: SV630NT3R5I, SV630NT5R4I, SV630NT8R4I, SV630NT012I, SV630NT021I, SV630NT026I

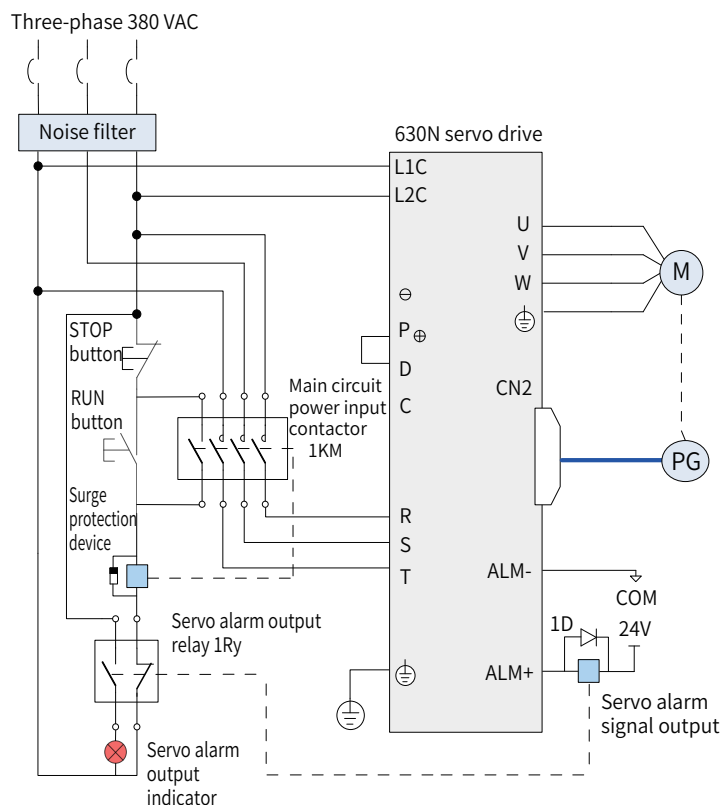

Figure 3-13 Main circuit wiring example of three-phase 380 V models



NOTE

- ◆ 1KM: Electromagnetic contactor; 1Ry: Relay; 1D: Flywheel diode
- ◆ DO is set as alarm output (ALM+/-). When the servo drive alarms, the power supply will be cut off automatically and the alarm indicator will be turned on.

3.2.5 Precautions for Main Circuit Wiring

- Do not connect the input power cables to the output terminals U, V, and W. Failure to comply will damage the servo drive.
- When cables are bundled in a duct, the cooling effect will be deteriorated. In this case, take the reduction ratio of the allowable current into consideration.
- When the temperature inside the cabinet is higher than the temperature limit of the cable, it is recommended to use a Teflon cable with a higher temperature limit. As the surface of regular cables may be easily hardened and cracked under a low temperature, take thermal insulation measures for cables laid in an environment with a low temperature.
- The bending radius of a cable must be 10 times longer than its outer diameter to prevent the internal conductor from breaking due to long-time bending.
- Use cables with a rated voltage above 600 VAC and rated temperature above 75° C. Under an ambient temperature of 30° C with normal cooling conditions, the allowable current density of the cable cannot exceed 8 A/mm² (total current < 50 A) or 5 A/mm² (total current > 50 A).
- The allowable current density (A/mm²) can be adjusted based on the following formula in case of high ambient temperatures or bundled cables.

$$\text{Allowable current density} = 8 \times \text{Reduction coefficient of conductor current-carrying density} \times \text{Current correction coefficient}$$

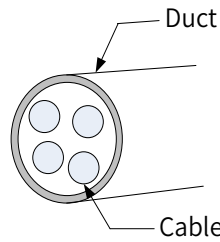

Table 3-11 Reduction coefficient of current-carrying density of the conductor

Number of Cables in the Same Duct	Current Reduction Coefficient
Less than 3	0.7
4	0.63
5-6	0.56
7-15	0.49

- Do not bundle power cables and signal cables together or route them through the same duct. Power cables and signal cables must be separated by a distance of at least 30 cm to prevent interference.
- After power-off, wait at least five minutes before operating the power terminals. This is because high voltage may be still present in the servo drive when the power supply is cut off.
- Do not turn on/off the power supply frequently. If ON/OFF interval is less than 1s, fault E740, E136, or E430 may be reported (see details in "[6 Troubleshooting](#)"). If the fault does occur, power on again based on the required ON/OFF interval. Because the capacitor in the main circuit is charged with a large current for 0.2s upon power on, the main circuit components inside the servo drive will be adversely affected by frequent ON/OFF. If frequent ON/OFF is required, ensure the time interval is at least one minute.
- Use a grounding cable with the same cross sectional area as the main circuit cable. If the cross sectional area of the main circuit cable is less than 1.6 mm², use a grounding cable with a cross sectional area of 2.0 mm².
- Ground the servo drive properly.
- Do not power on the servo drive when any screw of the terminal block or any cable is loose. Failure to comply may cause a fire.

3.2.6 Specifications of Main Circuit Options

The recommended circuit breakers and electromagnetic contactors are listed in the following table.

Table 3-12 Recommended circuit breakers and electromagnetic contactors

Main Circuit Power Supply	Servo Drive Model	Breaker		Contactor	
		Current (A)	Schneider Model	Current (A)	Schneider Model
Single-phase 220 V	SV630NS1R6I	4	OSMC32N2C4	9	LC1 D09
	SV630NS2R8I	6	OSMC32N2C6	9	LC1 D09
	SV630NS5R5I	16	OSMC32N2C16	9	LC1 D09
	SV630NS7R6I	10	OSMC32N2C10	9	LC1 D09
	SV630NS012I	20	OSMC32N2C16	9	LC1 D09
Three-phase 220 V	SV630NS7R6I	10	OSMC32N3C10	9	LC1 D09
	SV630NS012I	16	OSMC32N3C16	9	LC1 D09

Main Circuit Power Supply	Servo Drive Model	Breaker		Contactor	
		Current (A)	Schneider Model	Current (A)	Schneider Model
Single-phase 380 V	SV630NT3R5I	4	OSMC32N3C4	9	LC1 D09
	SV630NT5R4I	6	OSMC32N3C6	9	LC1 D09
	SV630NT8R4I	10	OSMC32N3C10	9	LC1 D09
	SV630NT012I	16	OSMC32N3C16	9	LC1 D09
	SV630NT017I	20	OSMC32N3C20	12	LC1 D12
	SV630NT021I	25	OSMC32N3C25	18	LC1 D18
	SV630NT026I	32	OSMC32N3C32	25	LC1 D25

3.3 Connecting the Servo Drive and Servo Motor Power Cables

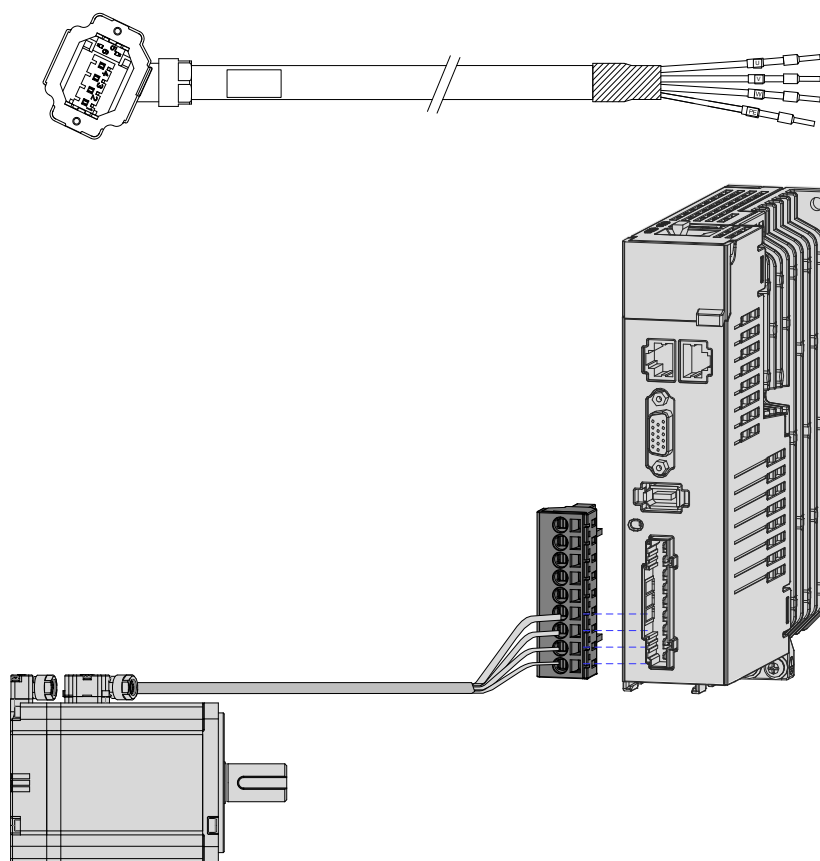
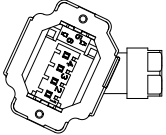
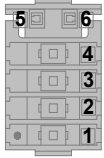

Figure 3-14 Example of the wiring between the servo drive and the terminal-type motor

Table 3-13 Power cable connector of terminal-type motors (motor side)

Outline Drawing of the Connector	Terminal Pin Layout	Applicable Flange Size ^[Note]																							
	<p data-bbox="667 309 888 338">Black 6-pin connector</p>  <table border="1" data-bbox="528 555 1027 808"> <thead> <tr> <th>Pin No.</th> <th>Signal Name</th> <th>Color</th> </tr> </thead> <tbody> <tr> <td>1</td> <td>PE</td> <td>Yellow/Green</td> </tr> <tr> <td>2</td> <td>W</td> <td>Red</td> </tr> <tr> <td>3</td> <td>V</td> <td>Black</td> </tr> <tr> <td>4</td> <td>U</td> <td>White</td> </tr> <tr> <td>5</td> <td>Brake</td> <td>Polarity</td> <td>Brown</td> </tr> <tr> <td>6</td> <td>Brake</td> <td>insensitive</td> <td>Blue</td> </tr> </tbody> </table>	Pin No.	Signal Name	Color	1	PE	Yellow/Green	2	W	Red	3	V	Black	4	U	White	5	Brake	Polarity	Brown	6	Brake	insensitive	Blue	<p data-bbox="1139 490 1358 519">Terminal-type motor:</p> <p data-bbox="1233 530 1257 560">40</p> <p data-bbox="1233 568 1257 598">60</p> <p data-bbox="1233 607 1257 636">80</p>
Pin No.	Signal Name	Color																							
1	PE	Yellow/Green																							
2	W	Red																							
3	V	Black																							
4	U	White																							
5	Brake	Polarity	Brown																						
6	Brake	insensitive	Blue																						



- ◆ The flange size refers to the width of the mounting flange.
- ◆ Power cable colors are subject to the colors of the actual product. Cable colors mentioned in this user guide refer to Inovance's cable colors.

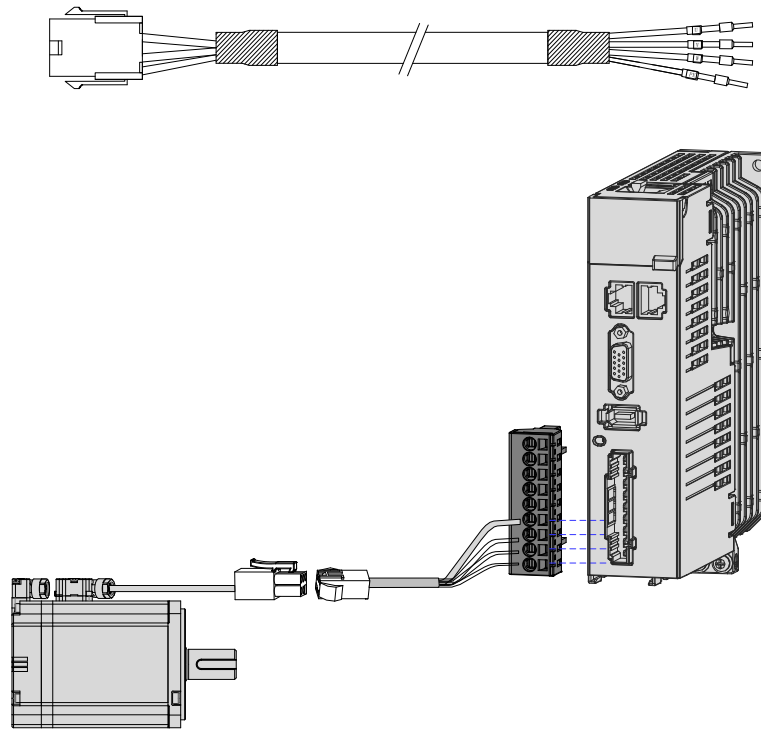
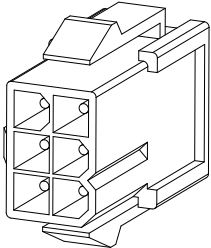
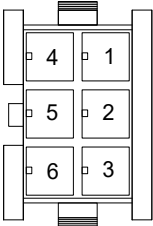
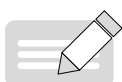

Figure 3-15 Example of the wiring between the servo drive and the lead wire-type motor

Table 3-14 Power cable connector of lead-wire type motors (motor side)

Outline Drawing of the Connector	Terminal Pin Layout	Applicable Flange Size ^[Note]																				
	<p style="text-align: center;">Black 6-pin connector</p>  <table border="1" data-bbox="550 633 1082 891"> <thead> <tr> <th>Pin No.</th> <th>Signal Name</th> <th>Color</th> </tr> </thead> <tbody> <tr> <td>1</td> <td>U</td> <td>White</td> </tr> <tr> <td>2</td> <td>V</td> <td>Black</td> </tr> <tr> <td>4</td> <td>W</td> <td>Red</td> </tr> <tr> <td>5</td> <td>PE</td> <td>Yellow/Green</td> </tr> <tr> <td>3</td> <td rowspan="2">Brake (polarity insensitive)</td> <td></td> </tr> <tr> <td>6</td> <td></td> </tr> </tbody> </table> <p>Recommendations: Plastic housing: MOLEX-50361736 Terminal: MOLEX-39000061</p>	Pin No.	Signal Name	Color	1	U	White	2	V	Black	4	W	Red	5	PE	Yellow/Green	3	Brake (polarity insensitive)		6		<p style="text-align: center;">Lead wire-type motor:</p> <p style="text-align: center;">40 60 80</p>
Pin No.	Signal Name	Color																				
1	U	White																				
2	V	Black																				
4	W	Red																				
5	PE	Yellow/Green																				
3	Brake (polarity insensitive)																					
6																						



NOTE

- ◆ The flange size refers to the width of the mounting flange.
- ◆ Power cable colors are subject to the colors of the actual product. Cable colors mentioned in this user guide refer to Inovance's cable colors.

Table 3-15 Connectors for power cables on the servo motor side

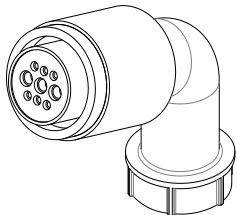
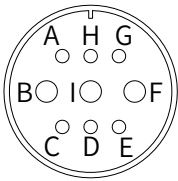
Outline Drawing of the Connector	Terminal Pin Layout	Applicable Flange Size																																						
	<p style="text-align: center;">MIL-DTL-5015 series 3108E20-18S aviation plug</p> <p style="text-align: center;">20-18 aviation plug</p>  <table border="1" data-bbox="604 1637 1176 2033"> <thead> <tr> <th colspan="2">New Structure</th> <th colspan="2">Old Structure</th> <th rowspan="2">Color</th> </tr> <tr> <th>Pin No.</th> <th>Signal Name</th> <th>Pin No.</th> <th>Signal Name</th> </tr> </thead> <tbody> <tr> <td>B</td> <td>U</td> <td>B</td> <td>U</td> <td>Blue</td> </tr> <tr> <td>I</td> <td>V</td> <td>I</td> <td>V</td> <td>Black</td> </tr> <tr> <td>F</td> <td>W</td> <td>F</td> <td>W</td> <td>Red</td> </tr> <tr> <td>G</td> <td>PE</td> <td>G</td> <td>PE</td> <td>Yellow/ Green</td> </tr> <tr> <td>C</td> <td rowspan="2">Brake (polarity insensitive)</td> <td></td> <td></td> <td></td> </tr> <tr> <td>E</td> <td></td> <td></td> <td></td> </tr> </tbody> </table>	New Structure		Old Structure		Color	Pin No.	Signal Name	Pin No.	Signal Name	B	U	B	U	Blue	I	V	I	V	Black	F	W	F	W	Red	G	PE	G	PE	Yellow/ Green	C	Brake (polarity insensitive)				E				<p style="text-align: center;">100 130</p>
New Structure		Old Structure		Color																																				
Pin No.	Signal Name	Pin No.	Signal Name																																					
B	U	B	U	Blue																																				
I	V	I	V	Black																																				
F	W	F	W	Red																																				
G	PE	G	PE	Yellow/ Green																																				
C	Brake (polarity insensitive)																																							
E																																								

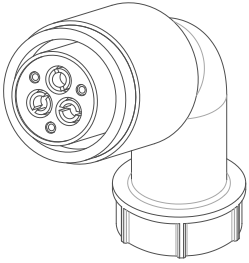
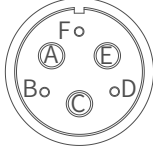
Outline Drawing of the Connector	Terminal Pin Layout	Applicable Flange Size																																						
	<p>MIL-DTL-5015 series 3108E20-22S aviation plug 20-22 aviation plug</p>  <table border="1" data-bbox="584 528 1195 826"> <thead> <tr> <th colspan="2">Definition of Y Series Terminal</th> <th colspan="2">Definition of Z series Terminal</th> <th rowspan="2">Color</th> </tr> <tr> <th>Pin No.</th> <th>Signal Name</th> <th>Pin No.</th> <th>Signal Name</th> </tr> </thead> <tbody> <tr> <td>A</td> <td>U</td> <td>A</td> <td>U</td> <td>Blue</td> </tr> <tr> <td>C</td> <td>V</td> <td>C</td> <td>V</td> <td>Black</td> </tr> <tr> <td>E</td> <td>W</td> <td>E</td> <td>W</td> <td>Red</td> </tr> <tr> <td>F</td> <td>PE</td> <td>F</td> <td>PE</td> <td>Yellow/ Green</td> </tr> <tr> <td></td> <td></td> <td>B</td> <td rowspan="2">Brake (polarity insensitive)</td> <td></td> </tr> <tr> <td></td> <td></td> <td>D</td> <td></td> </tr> </tbody> </table>	Definition of Y Series Terminal		Definition of Z series Terminal		Color	Pin No.	Signal Name	Pin No.	Signal Name	A	U	A	U	Blue	C	V	C	V	Black	E	W	E	W	Red	F	PE	F	PE	Yellow/ Green			B	Brake (polarity insensitive)				D		<p>180</p>
Definition of Y Series Terminal		Definition of Z series Terminal		Color																																				
Pin No.	Signal Name	Pin No.	Signal Name																																					
A	U	A	U	Blue																																				
C	V	C	V	Black																																				
E	W	E	W	Red																																				
F	PE	F	PE	Yellow/ Green																																				
		B	Brake (polarity insensitive)																																					
		D																																						

3.4 Connecting the Servo Drive and Servo Motor Encoder Cables

1 Installing the absolute encoder battery box

- The S6-C4 battery box contains the following items:

One plastic box

One 3.6 V/2600 mAh battery

Terminal block and crimping terminal

- Installing the battery box:

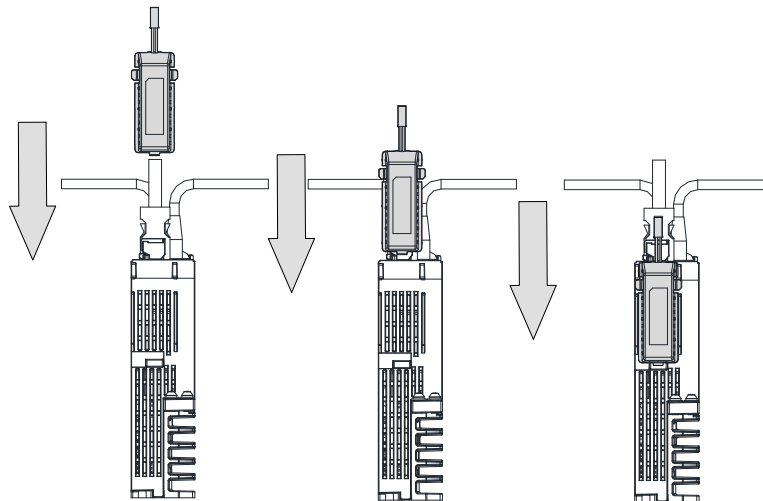
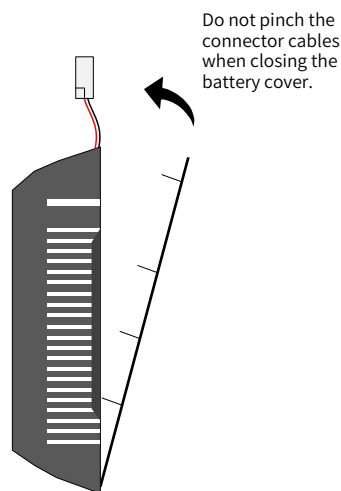

Figure 3-16 Installing the absolute encoder battery box (bottom view)

- Removing the battery box

The battery may have leakage liquids after a long-time use. It is recommended to replace the battery every two years. Remove the battery box in steps in reverse to those shown in the preceding figure.

When closing the battery box cover, do not pinch the connector cables.



 CAUTION



Improper use of the battery may result in battery leakage, corroding the components or causing battery explosion. Observe the following requirements during use:

- ◆ Insert the battery with correct +/- polarity.
- ◆ Using a battery continuously or leaving the battery unused inside the device can cause liquid leakage. The electrolyte inside the battery can corrode surrounding components and give rise to the danger of short circuit. Therefore, replace the battery regularly (recommended interval: every 2 years).
- ◆ Do not disassemble the battery because the internal electrolyte may spread out and cause physical injuries.
- ◆ Do not throw a battery into the fire or heat up the battery. Failure to comply may cause an explosion.
- ◆ Do not short-circuit the battery or strip off the battery tube. If terminals + and - of the battery contact the metal, a large current will be generated, not only deteriorating the battery power but also incurring the risk of explosion due to violent overheating.
- ◆ This battery is non-rechargeable.
- ◆ Dispose of the retired battery according to local regulations.

■ Selecting the battery model

Select an appropriate battery according to the following table.

Table 3-16 Description of the absolute encoder battery

Battery Model and Specifications	Items	Ratings			Condition
		Minimum Value	Typical Value	Maximum Value	
Output: 3.6 V, 2600 mAh Recommended manufacturer and model: Shenzhen Jieshun LS14500	External battery voltage (V)	3.2	3.6	5	In standby mode ^[2]
	Circuit fault voltage (V)	-	2.6	-	In standby mode
	Battery warning voltage (V)	2.85	3	3.15	-
	Current consumed by circuit (μA)	-	2	-	In normal status ^[1]
		-	10	-	In standby mode, shaft at a standstill
		-	80	-	In standby mode, shaft rotating
	Ambient temperature for operation (°C)	0	-	40	Same as that required by the motor
Ambient temperature for storage (°C)	-20	-	60		

The preceding data is obtained under an ambient temperature of 20°C.

- [1] During normal operation, the absolute encoder supports single-turn or multi-turn data counting and data transceiving. A well-connected encoder will, upon switch-on of the servo drive, enter normal operation status and transmit/receive data after a delay of 5s. Switching from standby mode to normal operation mode upon power-on requires the motor to rotate at a speed less than 10 RPM. Otherwise, the servo drive reports E740 (Encoder fault). In this case, you need to power on the servo drive again.
- [2] Standby mode means the servo drive is not powered on and the absolute encoder is powered up by an external battery to count the multi-turn data. In this case, data transceiving stops.

■ Design life of the battery

The following calculation only covers the current consumed by the encoder.

Suppose that the servo drive works normally for T1 in a day, the motor rotates for T2 after the servo drive is powered off, and the motor stops rotating for T3 after power-off (unit: hour (h)).

Example:

Table 3-17 Design life of the absolute encoder battery

Item	Working Time 1	Working Time 2
Days of working in different operating conditions in 1 year (day)	313	52
T1 (hour H)	8	0
T2 (hour H)	0.1	0
T3 (hour H)	15.9	24

Capacity consumed in 1 year = $(8 \text{ h} \times 2 \mu\text{A} + 0.1 \text{ h} \times 80 \mu\text{A} + 15.9 \text{ h} \times 10 \mu\text{A}) \times 313 + (0 \text{ h} \times 2 \mu\text{A} + 0 \text{ h} \times 80 \mu\text{A} + 24 \text{ h} \times 10 \mu\text{A}) \times 52 \approx 70 \text{ mAH}$

Design life = Battery capacity/Annual consumption = $2600 \text{ mAH}/70 \text{ mAH} = 37.1 \text{ years}$

2 Connecting the absolute encoder

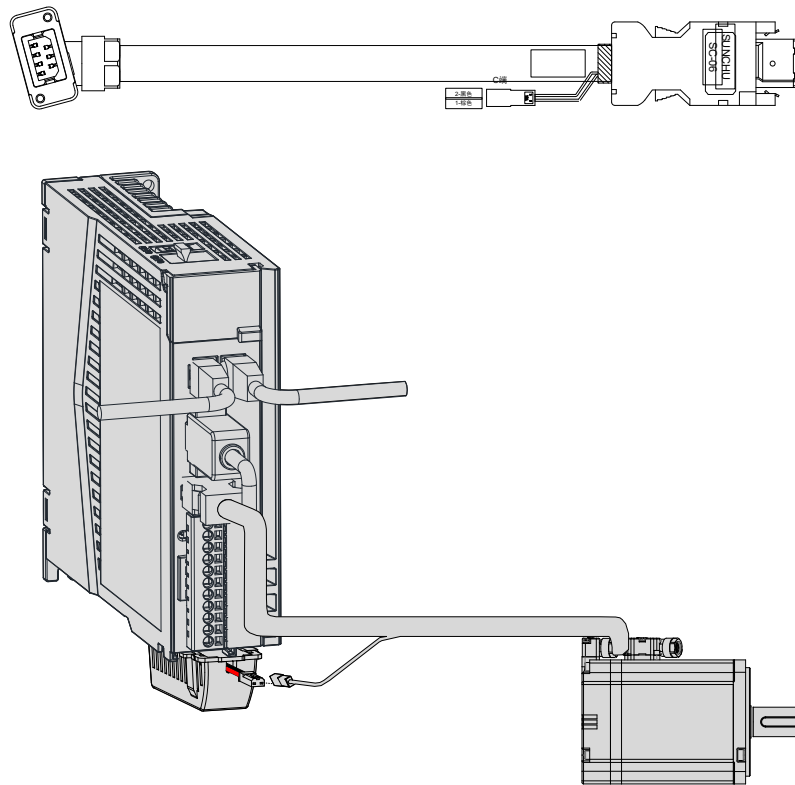

Figure 3-17 Wiring example of absolute encoder signals^[1]

[1] The preceding figure shows the wiring diagram of absolute encoder cables, which is similar to that of incremental encoder (without a battery box) cables.



NOTE

The encoder cable color is subject to the color of the actual product. Cable colors mentioned in this user guide refer to Inovance's cable colors.

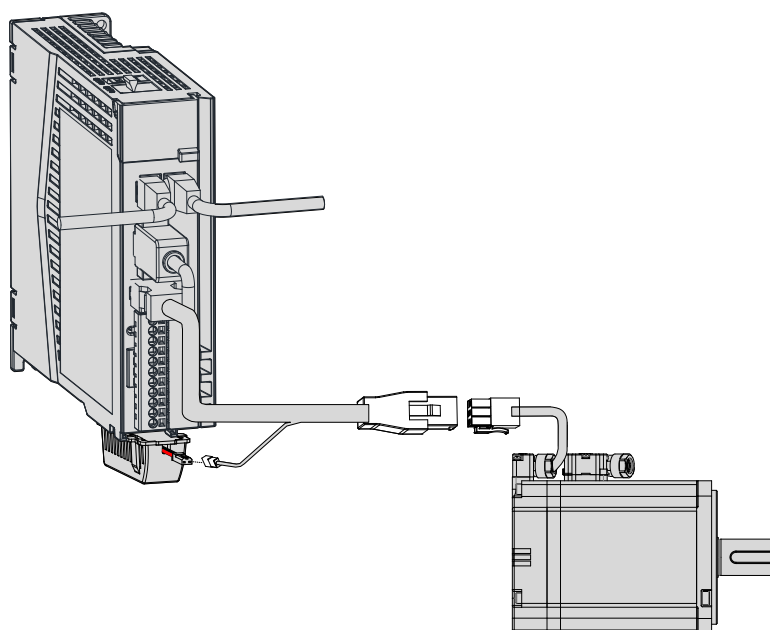

Lead wires of the battery box:

Pin No.	Color	Definition
1	Red	Power supply (+)

Pin No.	Color	Definition
2	Black	Power supply (-)

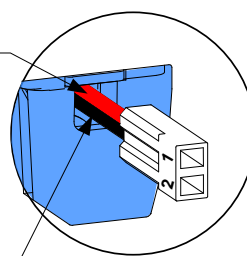

Figure 3-18 Lead wires of the absolute encoder battery



NOTE

- ◆ Store the battery under an allowable temperature and ensure reliable contact and sufficient battery power. Failure to comply may cause encoder data loss.
- ◆ Model of the battery box (battery included): S6-C4

Table 3-18 Encoder cable connector of terminal-type motors (motor side)

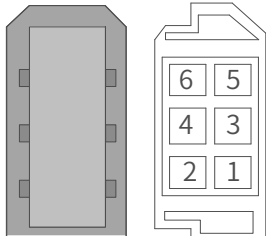
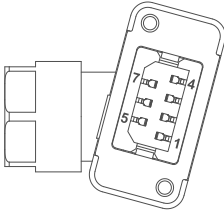
Outline Drawing and Pin Layout of the Connector				Applicable Flange Size ^[1]																																																	
Servo Drive Side		Motor Side		Terminal-type motors: 40 60 80																																																	
6-pin male (Left: connecting side Right: soldering side)		7-pin connector																																																			
																																																					
<table border="1"> <thead> <tr> <th>Pin No.</th> <th>Signal Name</th> <th>Color</th> <th>Type</th> </tr> </thead> <tbody> <tr> <td>1</td> <td>+5V</td> <td>Red</td> <td rowspan="2">Twisted pair</td> </tr> <tr> <td>2</td> <td>GND</td> <td>Orange</td> </tr> <tr> <td>5</td> <td>PS+</td> <td>Blue</td> <td rowspan="2">Twisted pair</td> </tr> <tr> <td>6</td> <td>PS-</td> <td>Purple</td> </tr> <tr> <td>Enclosure</td> <td>PE</td> <td>-</td> <td>-</td> </tr> </tbody> </table>	Pin No.	Signal Name	Color	Type	1	+5V	Red	Twisted pair	2	GND	Orange	5	PS+	Blue	Twisted pair	6	PS-	Purple	Enclosure	PE	-	-	<table border="1"> <thead> <tr> <th>Pin No.</th> <th>Signal Name</th> <th>Color</th> <th>Type</th> </tr> </thead> <tbody> <tr> <td>1</td> <td>PS+</td> <td>Blue</td> <td rowspan="2">Twisted pair</td> </tr> <tr> <td>2</td> <td>PS-</td> <td>Purple</td> </tr> <tr> <td>3</td> <td>DC+</td> <td>Brown</td> <td rowspan="2">Twisted pair</td> </tr> <tr> <td>4</td> <td>DC-</td> <td>Black</td> </tr> <tr> <td>5</td> <td>+5V</td> <td>Red</td> <td rowspan="2">Twisted pair</td> </tr> <tr> <td>6</td> <td>0V</td> <td>Orange</td> </tr> <tr> <td>7</td> <td>PE</td> <td>-</td> <td>-</td> </tr> </tbody> </table>	Pin No.	Signal Name	Color	Type	1	PS+	Blue	Twisted pair	2	PS-	Purple	3	DC+	Brown	Twisted pair	4	DC-	Black	5	+5V	Red	Twisted pair	6	0V	Orange	7	PE	-	-	
Pin No.	Signal Name	Color	Type																																																		
1	+5V	Red	Twisted pair																																																		
2	GND	Orange																																																			
5	PS+	Blue	Twisted pair																																																		
6	PS-	Purple																																																			
Enclosure	PE	-	-																																																		
Pin No.	Signal Name	Color	Type																																																		
1	PS+	Blue	Twisted pair																																																		
2	PS-	Purple																																																			
3	DC+	Brown	Twisted pair																																																		
4	DC-	Black																																																			
5	+5V	Red	Twisted pair																																																		
6	0V	Orange																																																			
7	PE	-	-																																																		

[1] The flange size refers to the width of the mounting flange.

Table 3-19 Encoder cable connector of lead wire-type motors (motor side)

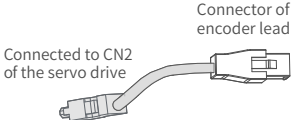
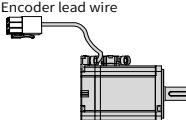
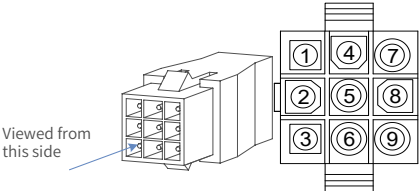
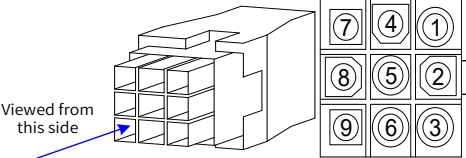
Outline Drawing and Pin Layout of the Connector				Applicable Flange Size ^[1]																																														
				Lead wire-type motors: 40 60 80																																														
9-pin connector		Encoder lead wire																																																
																																																		
<table border="1"> <thead> <tr> <th>Pin No.</th> <th>Signal Name</th> <th>Type</th> </tr> </thead> <tbody> <tr> <td>1</td> <td>Battery (+)</td> <td rowspan="2">-</td> </tr> <tr> <td>4</td> <td>Battery (-)</td> </tr> <tr> <td>3</td> <td>PS+</td> <td rowspan="2">Twisted pair</td> </tr> <tr> <td>6</td> <td>PS-</td> </tr> <tr> <td>9</td> <td>+5V</td> <td rowspan="3">-</td> </tr> <tr> <td>8</td> <td>GND</td> </tr> <tr> <td>7</td> <td>Shield</td> </tr> </tbody> </table>	Pin No.	Signal Name	Type	1	Battery (+)	-	4	Battery (-)	3	PS+	Twisted pair	6	PS-	9	+5V	-	8	GND	7	Shield	<table border="1"> <thead> <tr> <th>Pin No.</th> <th>Signal Name</th> <th>Color</th> <th>Type</th> </tr> </thead> <tbody> <tr> <td>1</td> <td>Battery (+)</td> <td>Blue</td> <td rowspan="2">Twisted pair</td> </tr> <tr> <td>4</td> <td>Battery (-)</td> <td>Blue and black</td> </tr> <tr> <td>3</td> <td>PS+</td> <td>Yellow</td> <td rowspan="2">Twisted pair</td> </tr> <tr> <td>6</td> <td>PS-</td> <td>Yellow and black</td> </tr> <tr> <td>9</td> <td>+5V</td> <td>Red</td> <td rowspan="3">-</td> </tr> <tr> <td>8</td> <td>GND</td> <td>Black</td> </tr> <tr> <td>7</td> <td>Shield</td> <td>-</td> </tr> </tbody> </table>	Pin No.	Signal Name	Color	Type	1	Battery (+)	Blue	Twisted pair	4	Battery (-)	Blue and black	3	PS+	Yellow	Twisted pair	6	PS-	Yellow and black	9	+5V	Red	-	8	GND	Black	7	Shield	-	
Pin No.	Signal Name	Type																																																
1	Battery (+)	-																																																
4	Battery (-)																																																	
3	PS+	Twisted pair																																																
6	PS-																																																	
9	+5V	-																																																
8	GND																																																	
7	Shield																																																	
Pin No.	Signal Name	Color	Type																																															
1	Battery (+)	Blue	Twisted pair																																															
4	Battery (-)	Blue and black																																																
3	PS+	Yellow	Twisted pair																																															
6	PS-	Yellow and black																																																
9	+5V	Red	-																																															
8	GND	Black																																																
7	Shield	-																																																
Recommendations: Plastic housing: AMP 172161-1 Terminal: AMP 770835-1																																																		

[1] The flange size refers to the width of the mounting flange.

Table 3-20 Absolute encoder cable connector (MIL-DTL-5015 series 3108E20-29S connector)

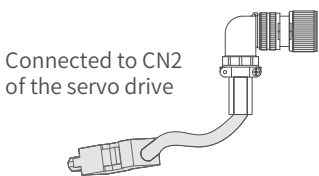
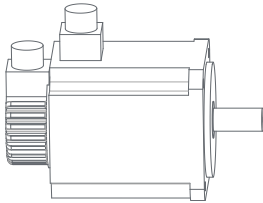
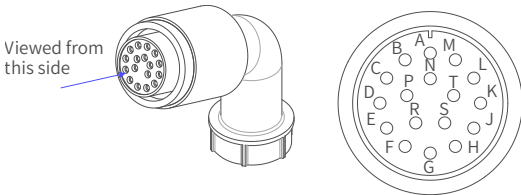
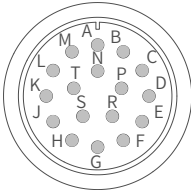
Outline Drawing and Terminal Layout of the Connector		Applicable Flange Size ^[1]																																																	
<p>Connector of the encoder lead wire</p> <p>Connected to CN2 of the servo drive</p> 	<p>Encoder connector</p> 	<p>100</p> <p>130</p> <p>180</p>																																																	
<p>20-29 connector</p> <p>Viewed from this side</p>  <table border="1" data-bbox="330 871 810 1126"> <thead> <tr> <th>Pin No.</th> <th>Signal Name</th> <th>Type</th> </tr> </thead> <tbody> <tr> <td>A</td> <td>PS+</td> <td rowspan="2">Twisted pair</td> </tr> <tr> <td>B</td> <td>PS-</td> </tr> <tr> <td>E</td> <td>Battery +</td> <td rowspan="2"></td> </tr> <tr> <td>F</td> <td>Battery -</td> </tr> <tr> <td>G</td> <td>+5V</td> <td rowspan="2"></td> </tr> <tr> <td>H</td> <td>GND</td> </tr> <tr> <td>J</td> <td>Shield</td> <td></td> </tr> </tbody> </table>	Pin No.		Signal Name	Type	A	PS+	Twisted pair	B	PS-	E	Battery +		F	Battery -	G	+5V		H	GND	J	Shield		<p>20-29 connector</p>  <table border="1" data-bbox="869 846 1321 1158"> <thead> <tr> <th>Pin No.</th> <th>Signal Name</th> <th>Color</th> <th>Type</th> </tr> </thead> <tbody> <tr> <td>A</td> <td>PS+</td> <td>Yellow</td> <td rowspan="2">Twisted pair</td> </tr> <tr> <td>B</td> <td>PS-</td> <td>Yellow and black</td> </tr> <tr> <td>E</td> <td>Battery+</td> <td>Blue</td> <td rowspan="2"></td> </tr> <tr> <td>F</td> <td>Battery-</td> <td>Blue and black</td> </tr> <tr> <td>G</td> <td>+5V</td> <td>Red</td> <td rowspan="2"></td> </tr> <tr> <td>H</td> <td>GND</td> <td>Black</td> </tr> <tr> <td>J</td> <td>Shield</td> <td></td> <td></td> </tr> </tbody> </table>	Pin No.	Signal Name	Color	Type	A	PS+	Yellow	Twisted pair	B	PS-	Yellow and black	E	Battery+	Blue		F	Battery-	Blue and black	G	+5V	Red		H	GND	Black	J	Shield	
Pin No.	Signal Name	Type																																																	
A	PS+	Twisted pair																																																	
B	PS-																																																		
E	Battery +																																																		
F	Battery -																																																		
G	+5V																																																		
H	GND																																																		
J	Shield																																																		
Pin No.	Signal Name	Color	Type																																																
A	PS+	Yellow	Twisted pair																																																
B	PS-	Yellow and black																																																	
E	Battery+	Blue																																																	
F	Battery-	Blue and black																																																	
G	+5V	Red																																																	
H	GND	Black																																																	
J	Shield																																																		

[1] The flange size refers to the width of the mounting flange.

3.5 Connecting Control Signal Terminal CN1

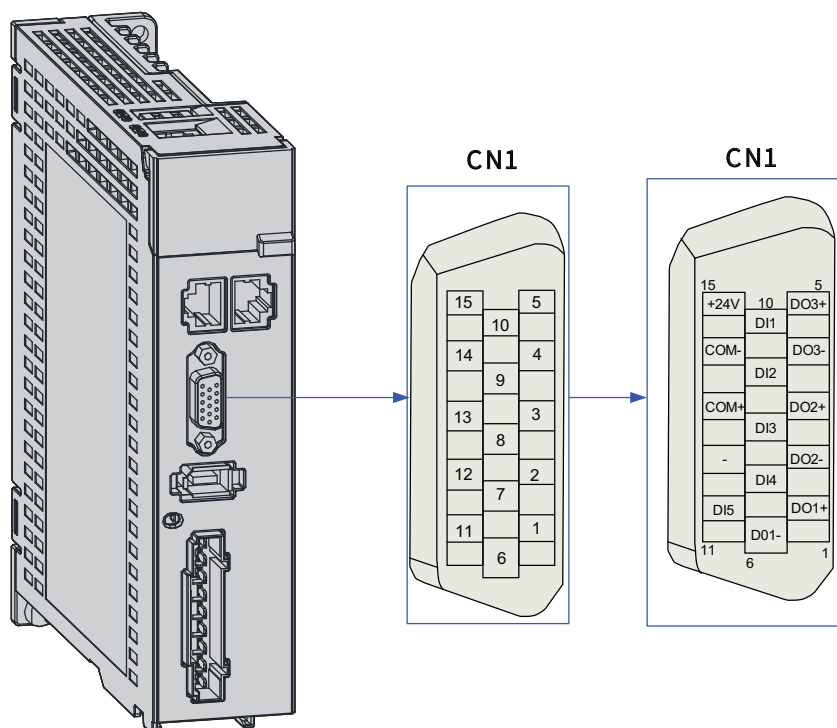

Figure 3-19 Pin layout of CN1

CN1 terminal: Plastic housing of the plug on the cable side: DB15P (SZTDK), black housing
 Core: HDB15P (SZTDK), male



◆ It is recommended to use cables of 24AWG to 26AWG.

3.5.1 DI/DO Signals

Table 3-21 Description of DI/DO signals

Signal Name	Function	Pin No.	Function	
DI1	P-OT	10	Positive limit switch	
DI2	N-OT	9	Negative limit switch	
DI3	HomeSwitch	8	Home switch	
DI4	TouchProbe2	7	Touch probe 2	
DI5	TouchProbe1	11	Touch probe 1	
General	+24V	15	Internal 24 V power supply, voltage range: 20 V to 28 V, maximum output current: 200 mA	
	COM-	14		
	COM+	13	Power input terminal (12 V to 24 V)	
	DO1+	S-RDY+	1	Servo ready
	DO1-	S-RDY-	6	
	DO2+	ALM+	3	Fault
	DO2-	ALM-	2	
	DO3+	BK+	5	Brake
	DO3-	BK-	4	

1 DI circuit

DI1 to DI5 circuits are the same. The following description takes DI1 circuit as an example.

- 1) The host controller provides relay output.
- When using the internal 24 V power supply of the servo drive

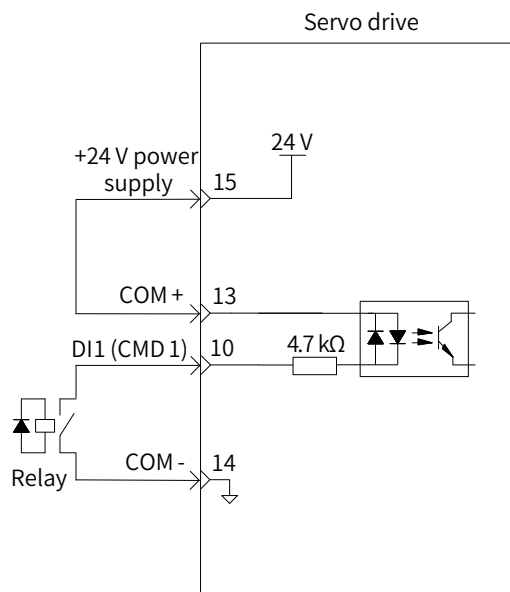

■ When using an external power supply

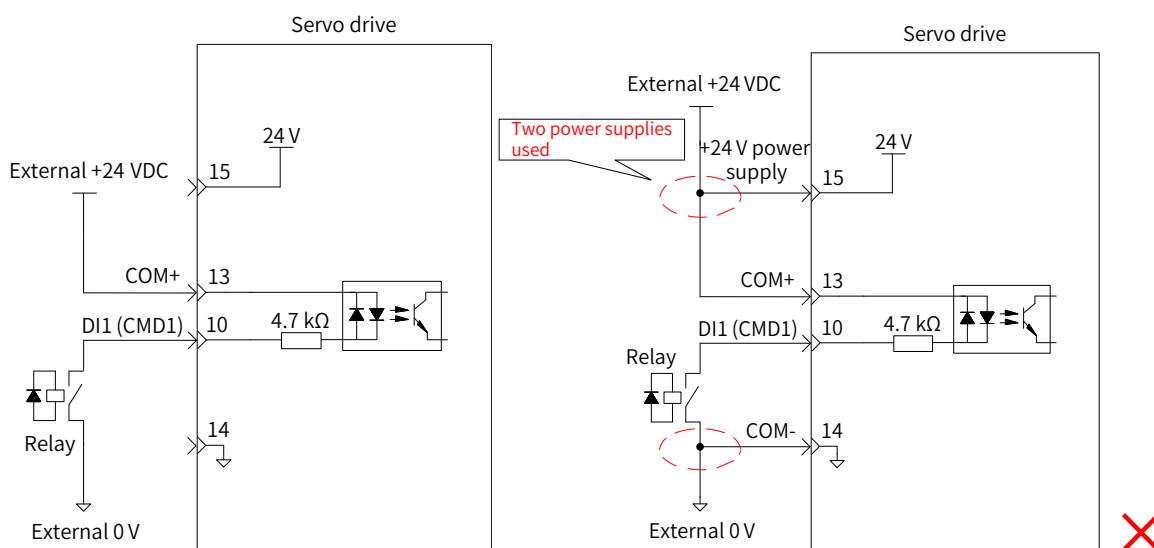

2) The host controller provides open-collector output.

■ When using the internal 24 V power supply of the servo drive

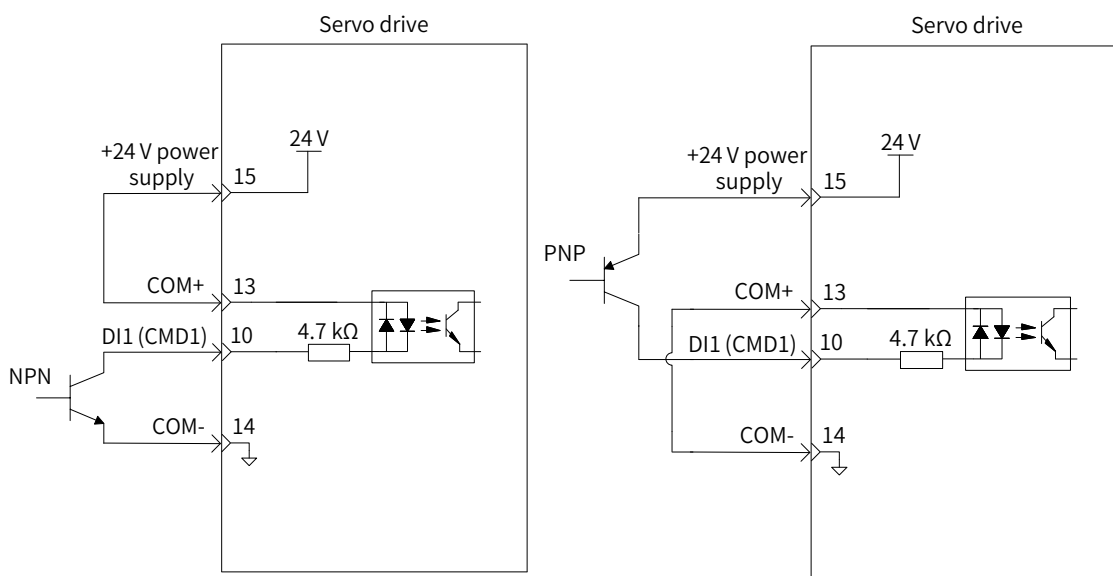

■ When using an external power supply

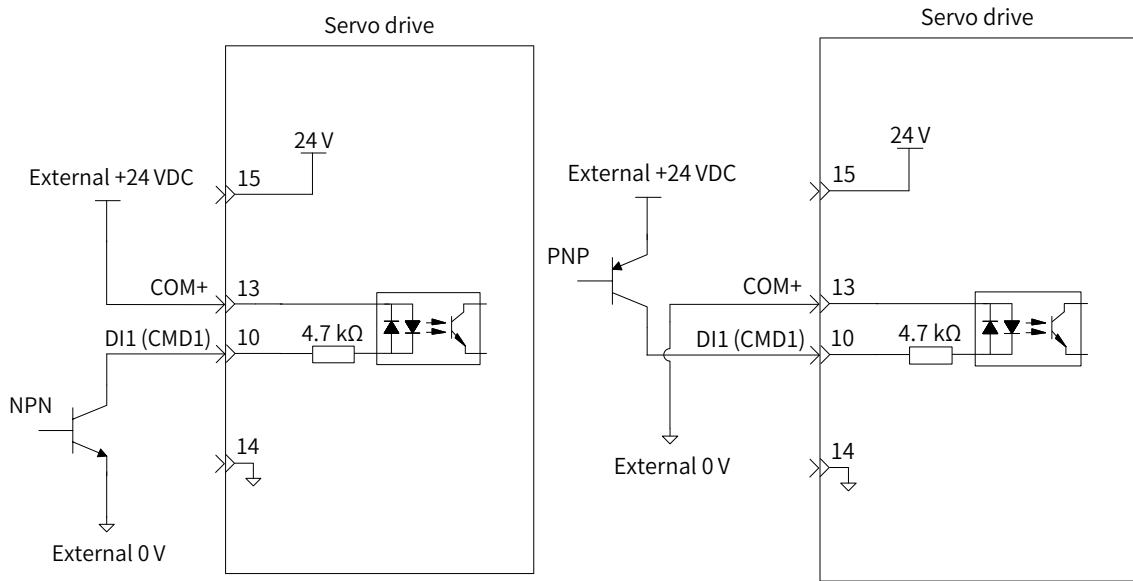

PNP and NPN inputs cannot be mixed in the same servo drive.

2 DO circuit

DO1 to DO3 circuits are the same. The following description takes DO1 circuit as an example.

- 1) The output terminal is connected to a relay-type device.

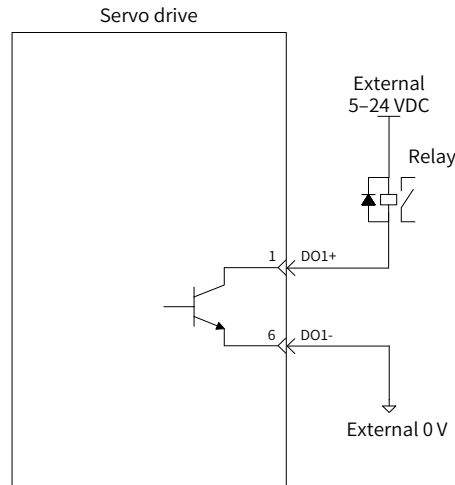

When the output terminal is connected to a relay-type device, a flywheel diode must be installed. Otherwise, the DO terminals may be damaged.

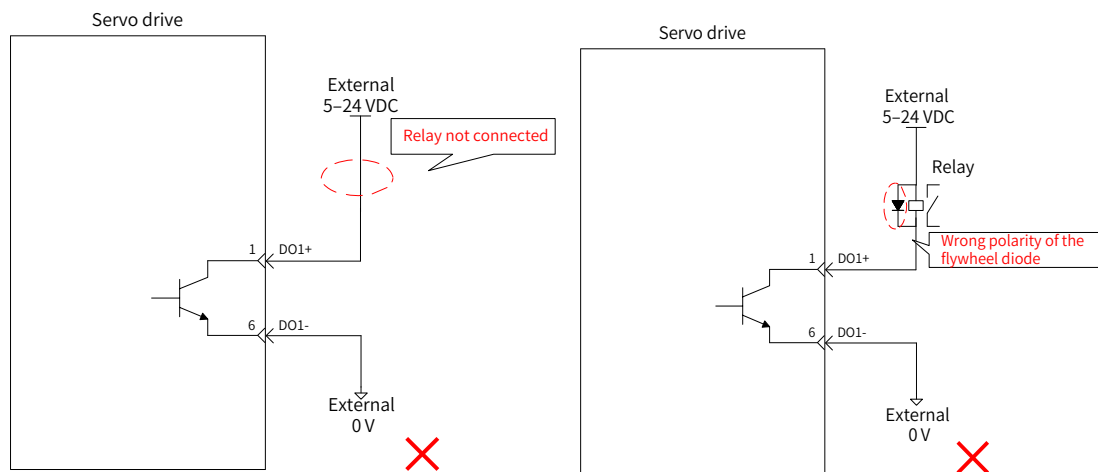

2) The output terminal is connected to an optocoupler-type device.

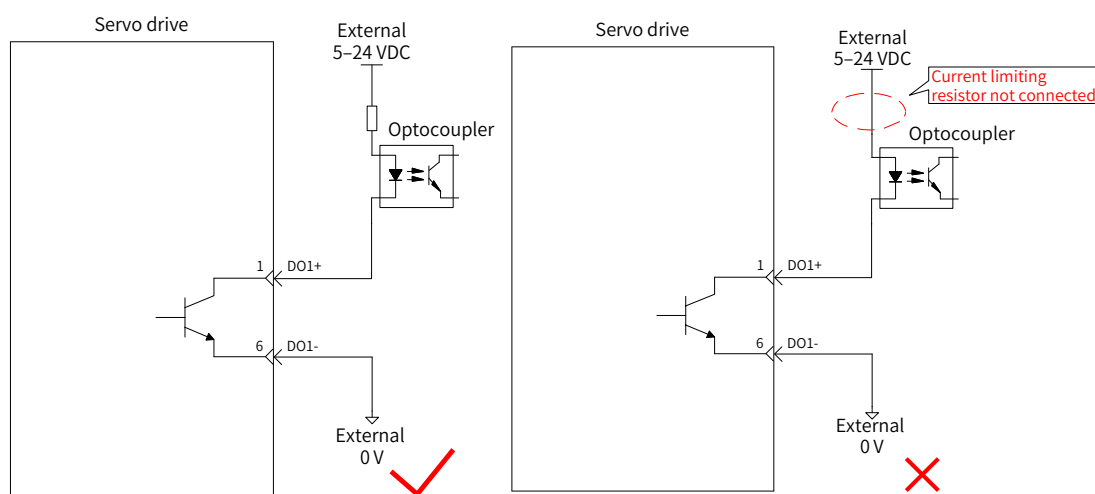

The maximum allowable voltage and current of the optocoupler output circuit inside the servo drive are as follows:

- Voltage: 30 VDC
- Current: DC 50 mA

3.5.2 Wiring of the Brake

The brake is used to prevent the servo motor shaft from rotating during non-operating status of the servo drive. This is to keep the motor and the mechanical load in locked positions.

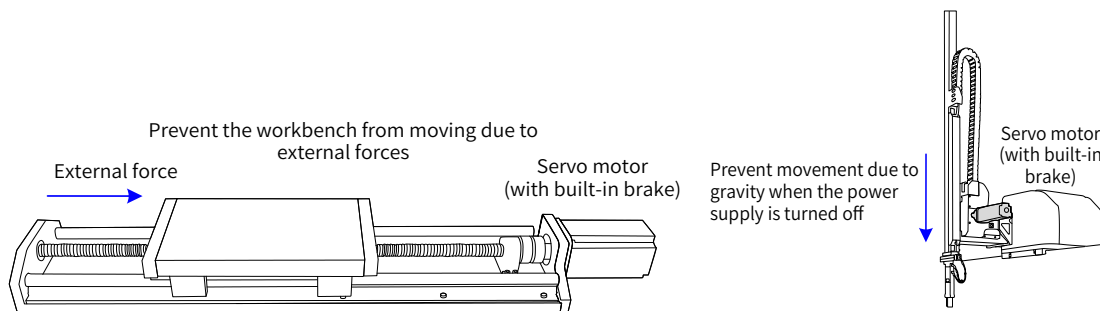

Figure 3-20 Application of the brake

CAUTION

- ◆ Use the built-in brake for position-lock only in the stop state.
- ◆ The brake coil has no polarity.
- ◆ Switch off the S-ON signal after the servo motor stops.
- ◆ When the servo motor with a built-in brake runs, the brake may generate a clattering sound. Such sound is normal.
- ◆ When brake coils are energized (brake released), magnetic flux leakage may occur at the shaft end. Be cautious when using magnetic sensors around the servo motor.

The brake input signal is connected without polarity differentiation. You need to prepare a 24 V external power supply. The following figure shows the standard wiring of the brake signal (BK) and the brake power supply.

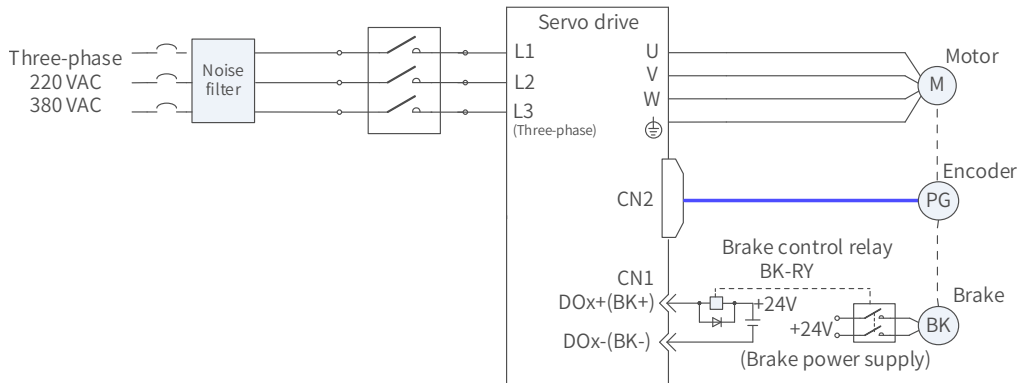

Figure 3-21 Wiring of the brake

Pay attention to the following precautions during wiring:

The length of the motor brake cable is subject to the voltage drop caused by cable resistance. The input voltage must be at least 21.6 V to enable the brake to work properly. The following table lists brake specifications of Inovance servo motors.

Table 3-22 Brake specifications

Motor Model	Holding Torque (N·m)	Supply Voltage (VDC) ±10%	Rated Power (W)	Coil Resistance (Ω) (±7%)	Excitation Current (A)	Apply Time (ms)	Release Time (ms)	Backlash (°)
MS1H1-05B/10B	0.32	24	6.1	94.4	0.25	≤ 40	≤ 20	≤ 1.5
MS1H1-20B/40B MS1H4-40B	1.5		7.6	75.79	0.32	≤ 60	≤ 20	≤ 1.5
MS1H1/H4-75B	3.2		10	57.6	0.42	≤ 60	≤ 40	≤ 1.0
MS1H3-85B/13C/18C	12		19.4	29.7	0.81	≤ 120	≤ 60	≤ 0.5
MS1H2-10C/15C/20C/25C	8		23	25	0.96	≤ 85	≤ 30	≤ 0.5
MS1H2-30C/40C/50C	16		27	21.3	1.13	≤ 100	≤ 60	≤ 0.5
MS1H3-29C/44C/55C/75C	50		40	14.4	1.67	≤ 200	≤ 100	≤ 0.5



NOTE

- ◆ The brake cannot share the same power supply with other electrical devices. This is to prevent malfunction of the brake due to voltage or current drop caused by other working devices.
- ◆ It is recommended to use cables of 0.5 mm² and above.

3.6 Wiring of Communication Signals CN3/CN4

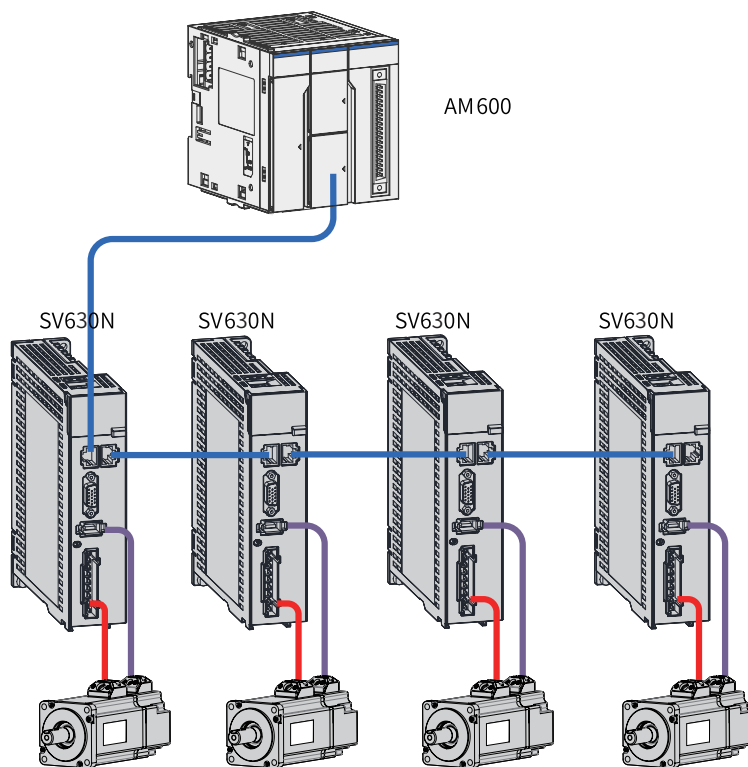

Figure 3-22 Network topology

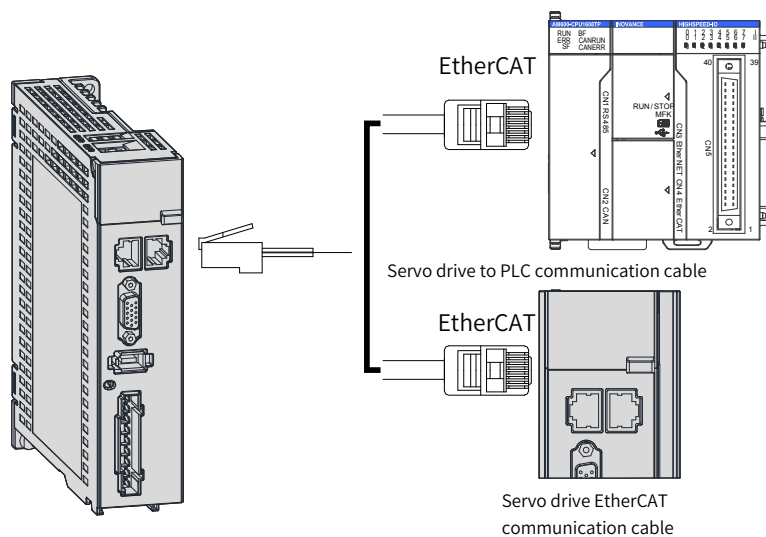

Figure 3-23 Wiring of communication cables

3.6.1 Pin Assignment of Communication Signal Connectors

CN3 and CN4 connectors are the EtherCAT interface connectors. CN3 (IN) is connected to the master and CN4 (OUT) is connected to the next slave.

Table 3-23 Pin assignment of CN3 and CN4

Pin No.	Name	Description	Terminal Pin Layout
1	TD+	Data transmitting (+)	
2	TD-	Data transmitting (-)	
3	RD+	Data receiving (+)	
4 and 5	-	-	
6	RD-	Data receiving (-)	
7 and 8	-	-	
9	TD+	Data transmitting (+)	
10	TD-	Data transmitting (-)	
11	RD+	Data receiving (+)	
12 and 13	-	-	
14	RD-	Data receiving (-)	
15 and 16	-	-	

3.6.2 Communication Cable Selection

■ Principle for cable selection

Cable Specifications	Supplier	Price
0.2 m to 10 m	Inovance, Haituo and others	See the following content for information on cable ordering.
Above 10 m		The cable price is added by RMB 5 for every additional 1 m based on the price of S6-L-T04-10.0. The cable price is also related to the magnitude of the order.



◆ Cable selection is subject to the cable supplier. See "Instructions for purchasing servo encoder cables/power cables" in Inovance business system.

■ Basic information of Inovance EtherCAT communication cables

Cable models are described in the following figure.

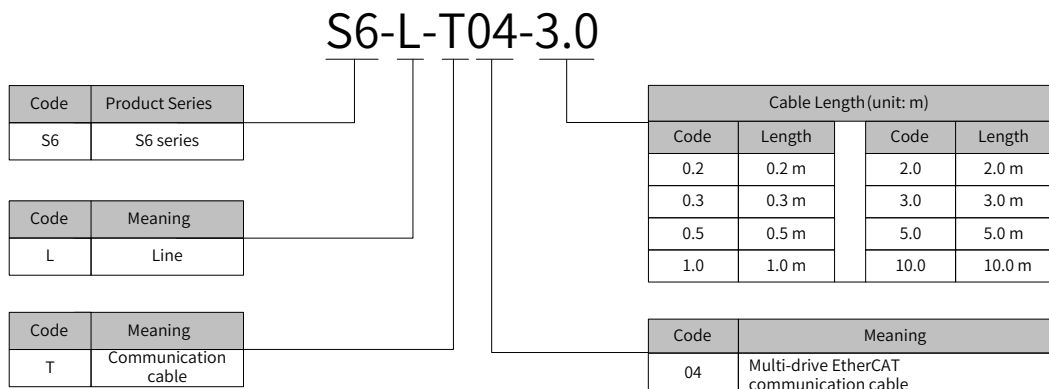

■ Cable ordering information

Material Code	Cable Model	Length (m)
15040261	S6-L-T04-0.3	0.3
15040262	S6-L-T04-3.0	3.0
15041960	S6-L-T04-0.2	0.2
15041961	S6-L-T04-0.5	0.5
15041962	S6-L-T04-1.0	1.0
15041963	S6-L-T04-2.0	2.0
15041964	S6-L-T04-5.0	5.0
15041965	S6-L-T04-10.0	10.0

Cables need to be purchased from Haituo. (Guide price: The cable price is added by RMB 5 for every additional 1 m based on the price of S6-L-T04-10.0. The cable price is also related to the magnitude of the order.)

◆ The thickness of the head of dual network ports cannot be too large, otherwise, interference may occur. The recommended thickness is 2.4 mm, as shown below.



NOTE

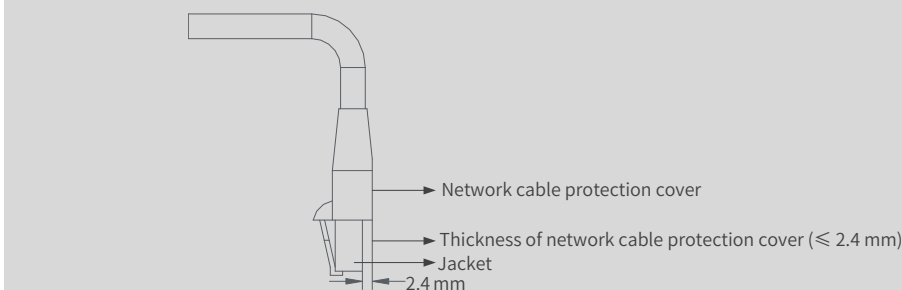

■ Specifications

Item	Description
UL certification	UL-compliant
Cat 5e cable	Cat 5e cable
Double shield	Braided shield (coverage: 85%), aluminum foil shield (coverage: 100%)
Environment worthiness	Ambient temperature: -30°C to +60°C, resistant to industrial oil and corrosive acid and alkali
EMC test standard	GB/T 24808-2009

3.6.3 Communication Connection with PC (RS232 Communication)

Connect the servo drive and the PC by using the PC communication cable as shown below. It is recommended to use the common communication interface RS232.

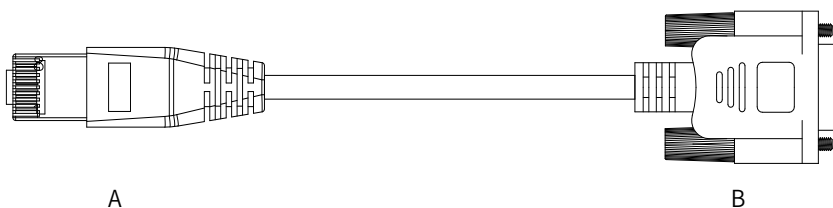

Figure 3-24 Outline drawing of the PC communication cable

Table 3-24 Connection relation between the servo drive and PC communication cable pins

RJ45 on Servo Drive Side (A)		DB9 on PC Side (B)	
Signal Name	Pin No.	Signal Name	Pin No.
RS232-TXD	6	PC-RXD	2
RS232-RXD	7	PC-TXD	3
GND	8	GND	5
PE (shield)	Enclosure	PE (shield)	Enclosure

The definition of DB9 terminal on the PC side is shown in the following table.

Table 3-25 Pin definition of DB9 ("B" in the preceding figure) on the PC side

Pin No.	Definition	Description	Terminal Pin Layout
2	PC-RXD	PC receiving end	
3	PC-TXD	PC transmitting end	
5	GND	Ground	
Enclosure	PE	Shield	

If the host controller is not equipped with serial ports and offers an USB interface only, use a serial-to-USB converter.

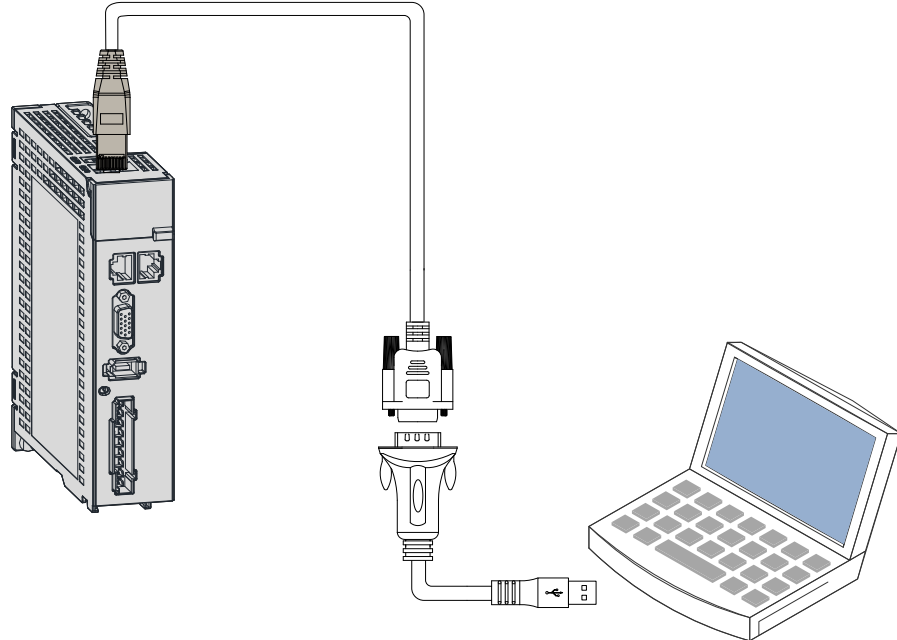

Figure 3-25 Serial-to-USB conversion

Recommendation:
 Manufacture: Z-TEK
 Model: ZE551A, equipped with a 0.8 m USB extension cable
 Chip model: FT232

3.7 Definition and Connection of STO terminals

This section describes the definition and functions of the I/O terminal (CN6) for the safe torque off (STO) functional safety function.

1 Terminal layout

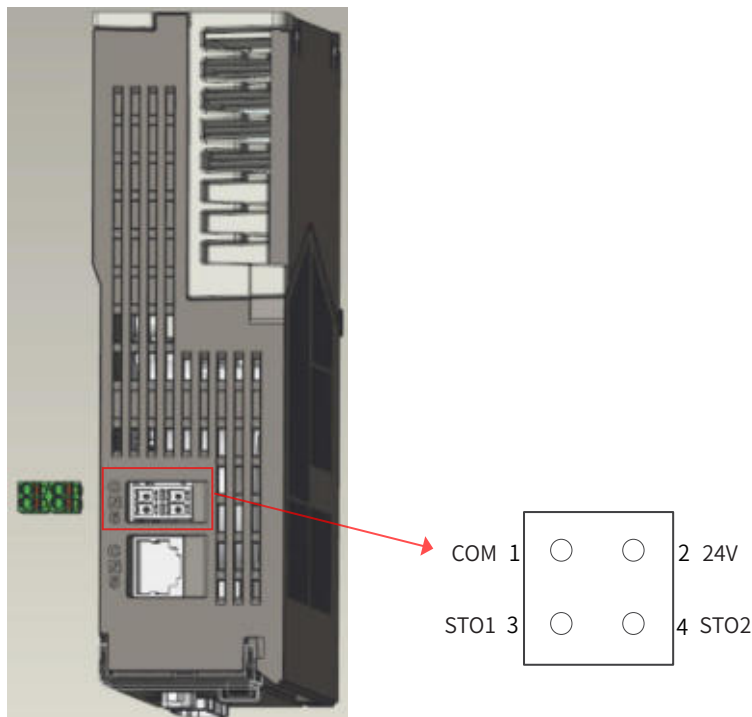

1) Pin assignment of the input connector

Terminal	Pin No.	Name	Value	Description
CN6	1	COM	0 V	STO reference ground
	2	24V	24 V	24 V power supply
	3	STO1	-	Control input for STO1
	4	STO2	-	Control input for STO2

- Two isolated inputs STO1 and STO2 are configured to dual-channel inputs of STO function.
- For convenient and safe installation, an additional pin with supply voltage (+24V) is integrated. If the safety circuit is installed without the STO function, the bridging of the 24 volts is needed.



NOTE

Remove the short-circuit jumper when the STO function is needed in actual applications.

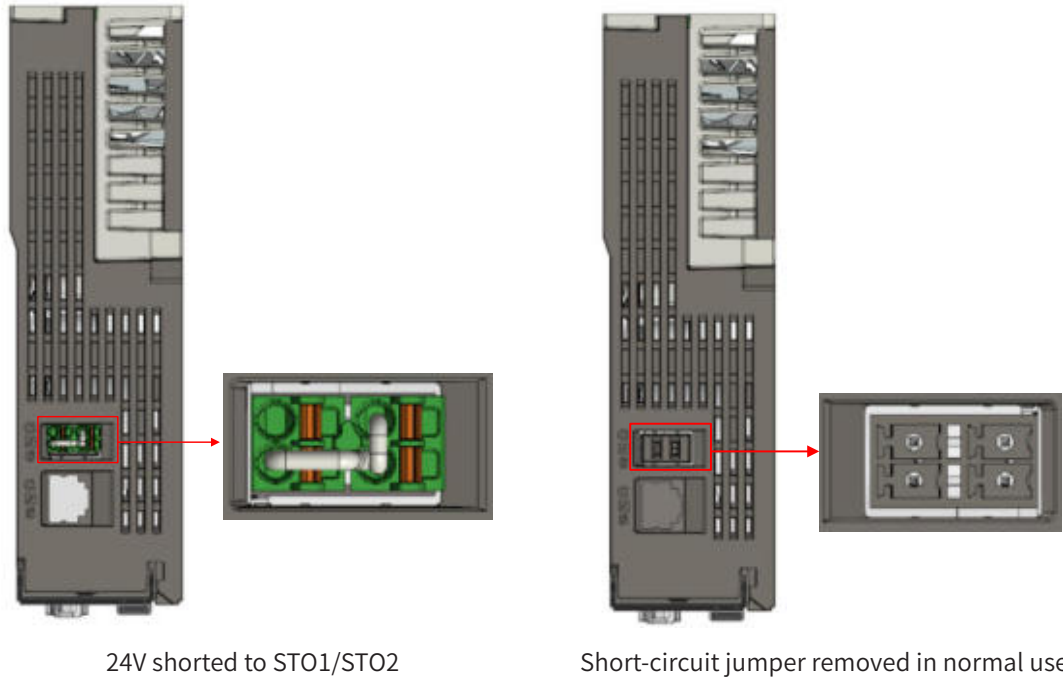

2 Electrical specifications and connections of the input circuit

This section describes the characteristics of the input signals assigned to the CN6 connector.

■ Specifications

The servo drive can operate normally only if the input status of both STO1 and STO2 is "1" or "H".

If the input status of either STO1 or STO2 (or both) is "0" or "L", the servo drive cannot run.

■ Electrical characteristics of the safety request input signal

Items	Characteristics	Description
Voltage range	24 VDC ($\pm 15\%$)	-
Input current	4 mA (Typ.)	Value per channel
Standards of logic levels	"0" < 3 V, "1" > 15 V	-
Digital input impedance	5.78 k Ω	-

■ Example of external 24 V connection

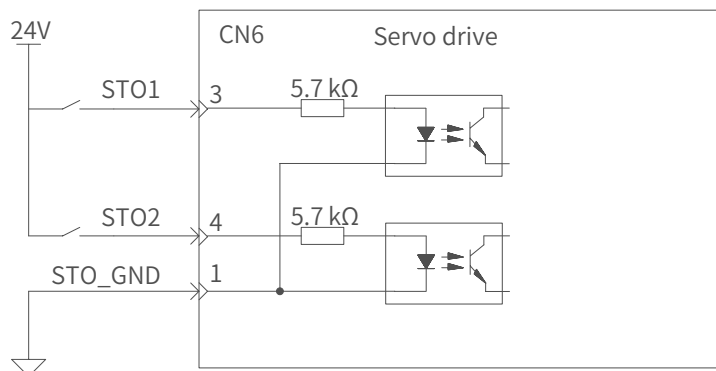

- Example of internal 24 V connection

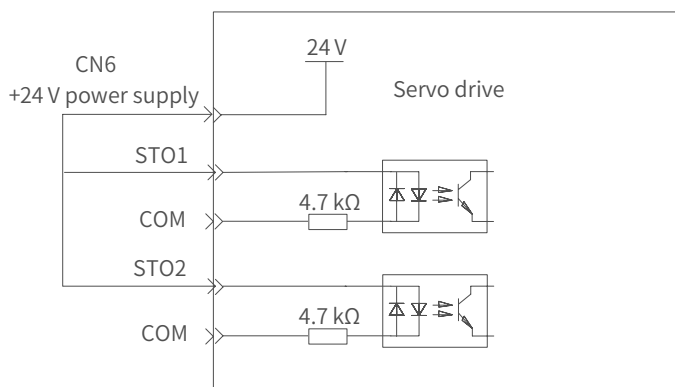

3 EMC requirements

- To avoid short circuit between two adjacent conductors, either use a shielded cable with its shield connected to the protective ground or a flat cable with one earthed conductor between two signal conductors.
- Double-shielded or single-shielded twisted multi-pair cables are strongly recommended.
- Fix and ground the cable shield using a piece of conductive metal.

Example of cable clamp:

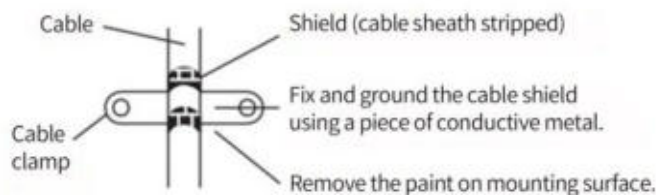

- The maximum allowable cable length between the drive and the activation switch is 30 m.

4 Additional requirements

- All cables must be well protected, routed, and clamped where practicable.
- Ensure that there is no pulling or pinching on the cables during installation.
- To avoid the cable faults that commonly occur during cabling the DIs of the STO, route the two channels through two routes, or protect the cable with a double-layer shield.

Cable	Description
Type	Low voltage, double-shielded or single-shielded twisted multi-pair cable
Maximum size	0.8 mm ² (18 AWG)
Minimum size	0.3 mm ² (28 AWG)
Maximum length	30 m between STO inputs and the operating contact

3.8 Anti-interference Measures for Electrical Wiring

Take the following measures to suppress interference:

- Ensure the lengths of the command input cable and the encoder cable are below 3 m and 20 m respectively.
- Use a thick cable as the grounding cable (above 2.0 mm²).

- 1) It is recommended to adopt D class (or higher) grounding (grounding resistance below 100 Ω).
- 2) Adopt single-point grounding.
 - Use a noise filter to prevent radio frequency interferences. In domestic applications or an unfavorable environment with strong power noise interference, install a noise filter on the input side of the power cable.
 - To prevent malfunction caused by electromagnetic interference, take the following measures:
 - 1) Install the host controller and the noise filter near the servo drive.
 - 2) Install a surge protection device on the relay, solenoid and electromagnetic contactor coils.
 - 3) Separate the electrical circuit from the electronic circuit during wiring and keep a distance of at least 30 cm between them. Do not put these cables in the same duct or bundle them together.
 - 4) Do not share the same power supply with an electric welder or electrical discharge machine. When the servo drive is placed near a high-frequency generator, install a noise filter on the input side of the power cable.

3.8.1 Anti-interference Wiring Example and Grounding

The servo drive uses high-speed switch elements in the main circuit. The switching noise may affect the normal operation of the system due to different peripheral wiring and grounding of the servo drive. Therefore, wire and ground the servo drive properly, and add a noise filter if necessary.

1 Anti-interference wiring example

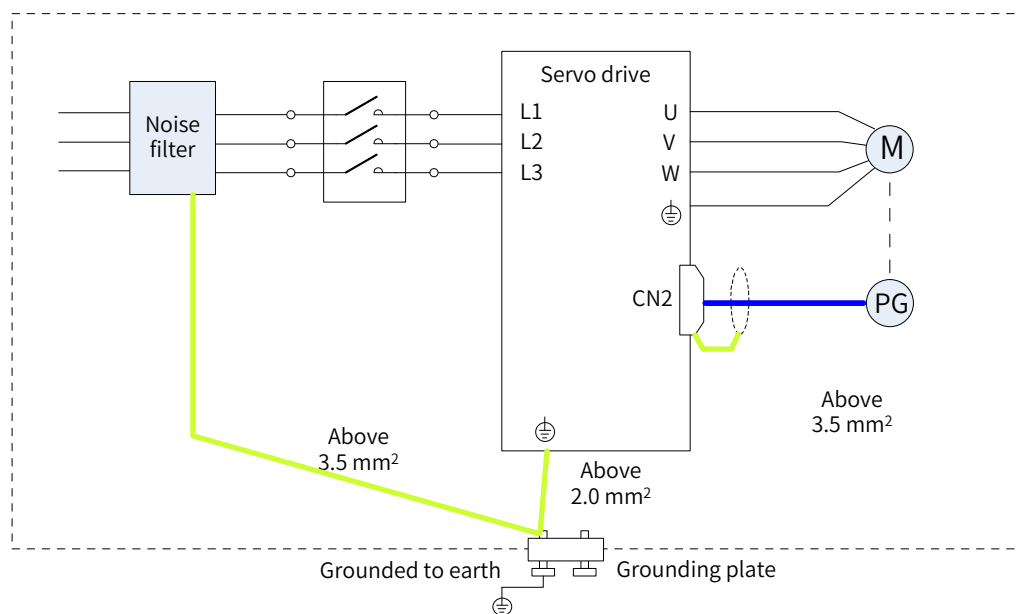

Figure 3-26 Anti-interference wiring example

For the grounding cable connected to the enclosure, use a cable of at least 3.5 mm² (braided copper cables recommended).

If a noise filter is used, observe the precautions described in ["3.7 Definition and Connection of STO terminals"](#).

2 Grounding

To prevent potential electromagnetic interferences, observe the following instructions during grounding.

- 1) Grounding the motor enclosure

Connect the grounding terminal of the servo motor to the PE terminal of the servo drive and ground the PE terminal properly.

- 2) Grounding the encoder cable shield

Ground both ends of the encoder cable shield.

3.8.2 Instructions for Use of the Noise Filter

To prevent interference from power cables and reduce impact of the servo drive to other sensitive devices, install a noise filter on the input side of the power supply according to the magnitude of the input current. In addition, install a noise filter on the power cable part of peripheral devices if necessary. To ensure the filtering effect, observe the following requirements when installing and wiring the noise filter.

- Do not put the input and output cables of the noise filter in the same duct or bundle them together.

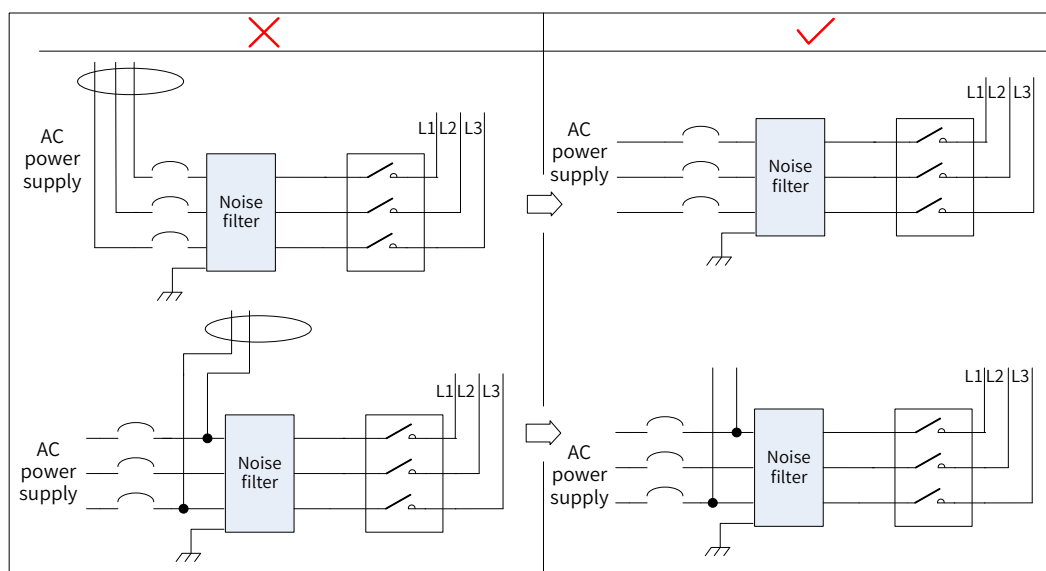

Figure 3-27 Separate routing of input and output cables

- Do not lay the grounding cable and the power output cable of the noise filter in the same duct.

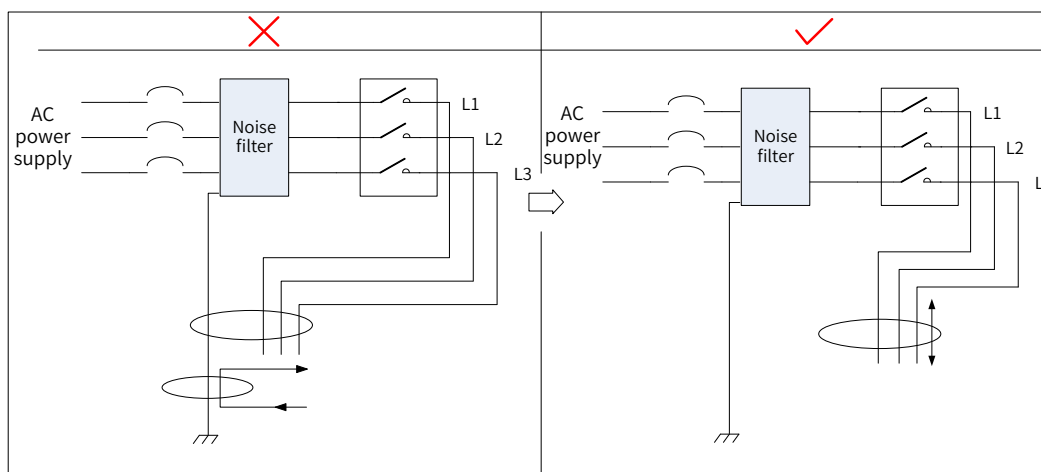

Figure 3-28 Separate routing of the grounding cable and the power output cable

- Use a separate, thick grounding cable as short as possible for the noise filter. Do not share the same

grounding cable with other grounding devices.

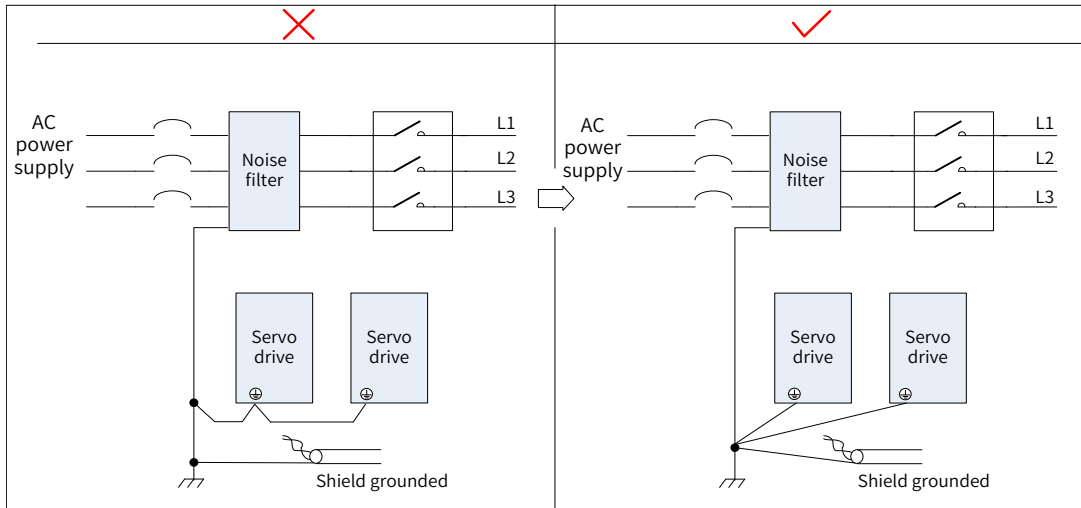

Figure 3-29 Single-point grounding

- Ground the noise filter installed inside the control cabinet.

If the noise filter and the servo drive are installed in the same control cabinet, secure the noise filter and the servo drive on the same metal plate. Make sure the contact part is conductive and well bonded, and ground the metal plate properly.

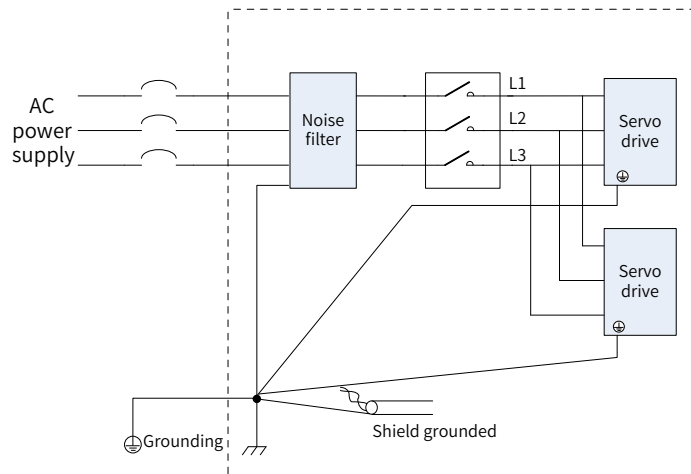

Figure 3-30 Grounding cable of the noise filter

3.9 Precautions for Use of Cables

- Do not bend or apply any tension to cables. The conductor of a signal cable is only 0.2 mm or 0.3 mm in diameter. Handle the cables carefully to prevent fracture.
- Use flexible cables for cable carriers. This is because ordinary cables may be easily damaged after being bent for a long time. Cables suitable for small-power servo motors do not fit for cable carriers.

Ensure the following requirements are fulfilled for use of cable carriers:

- Ensure that the bending radius of the cable is 10 times longer than its outer diameter.
- Do not secure or bundle the cables inside the cable carrier. Cables can be bundled and secured only at the two fixed ends of the cable carrier.
- Do not wind or twist the cables.

- Ensure the space factor inside the cable carrier is below 60%.
- Do not use cables with different sizes together. This is to prevent thin cables from being crushed by thick cables. If thick and thin cables need to be used together, use a spacer plate to separate them.

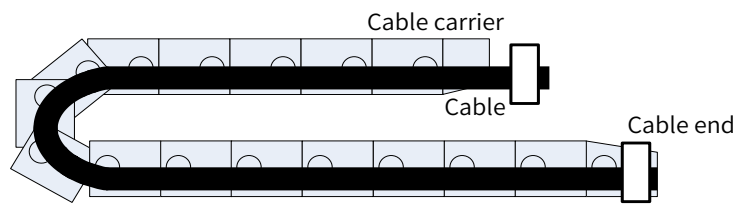

Figure 3-31 Cable carrier

4 Keypad Display and Operations

4.1 Introduction to the Keypad

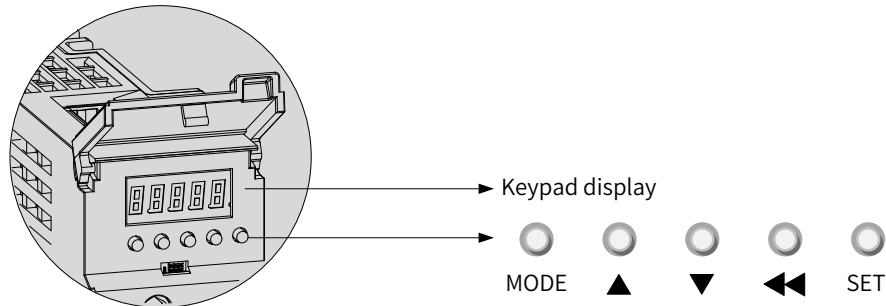







Figure 4-1 Appearance of the LED keypad

The keypad on the SV630N servo drive consists of five LEDs and five buttons. The keypad is used for data display, parameter settings, password settings, and general function executions. When the keypad is used for parameter settings, the functions of the buttons are described as follows.

Table 4-1 Functions of buttons

Name	Symbol	Description
MODE		Used to switch the mode and return to the previous menu.
UP		Used to increase the value of the blinking digit.
DOWN		Used to decrease the value of the blinking digit.
SHIFT		Used to shift the blinking digit for viewing the high digits of a number consisting of more than 5 digits.
SET		Used to enter the next menu and save parameter settings.

4.2 Display

The keypad displays the status, parameters, faults, and monitored values during operation.

- Status display: Displays current servo drive status, such as servo ready or running.
- Parameter display: Displays parameters and their setpoints.
- Fault display: Displays faults and warnings that occur on the servo drive.
- Monitored value display: Displays present running parameters of the servo drive.

4.2.1 Mapping Relation Between Keypad Display and Operation Objects

The mapping relation between the parameter (decimal) displayed by the keypad and the object dictionary operated by the host controller (hexadecimal, "Index" and "Sub-index") is as follows:

Object dictionary index = 0x2000 + Parameter group number

Object dictionary sub-index = Hexadecimal offset within the parameter group + 1

Example:

Display	Object Dictionary Operated by the Host Controller
H00-00	2000-01h
H00-01	2000-02h
...	...
H01-09	2001-0Ah
H01-10	2001-0Bh
...	...
H02-15	2002-10h



NOTE

The following describes the displayed content and parameter settings on the keypad (decimal) side, which are different from those displayed on the software tool (hexadecimal). Make necessary conversions when performing operations through the software tool in the host controller.

4.2.2 Display Modes Switchover

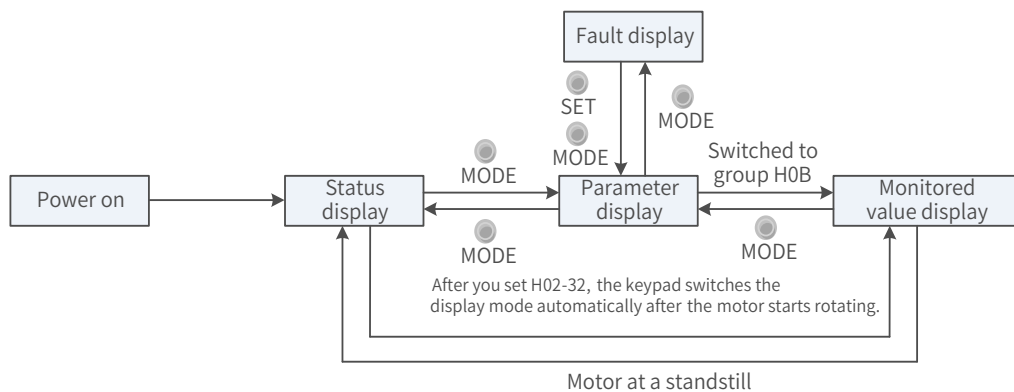





Figure 4-2 Switchover between different display modes

- After power-on, the keypad enters status display mode.
- Press  to switch between different modes, as shown in the preceding figure.
- In the status display mode, set H02-32 (Default keypad display) and select parameters to be monitored. When the motor rotates, the keypad automatically switches to the monitored value display mode. After the motor stops, the keypad automatically returns to the status display mode.
- In the parameter display mode, set parameters in group H0B to select the parameters to be pre-monitored. After setting, the keypad switches to the monitored value display mode.
- Once a fault occurs, the keypad enters the fault display mode immediately, and all the five LEDs blink. Press  to stop the LEDs from blinking, and then press  to switch to the parameter display mode.

4.2.3 Status Display

Display	Name	Display Condition	Meaning
	reset (servo initialization)	Upon power-on	The servo drive is in the initialization or reset status. After initialization or reset is done, the servo drive automatically switches to other status.
	nr (servo not ready)	Initialization done, but servo drive not ready	As the main circuit is not powered on, the servo drive is not ready to run. See " 6 Troubleshooting " for details.
	ry (servo ready)	Servo drive ready	The servo drive is ready to run and waits for the S-ON signal to be sent from the host controller.
	rn (servo running)	S-ON signal activated	The servo drive is running.
	1-A (control mode)	-	Displays present operation mode of the servo drive in hexadecimal digits. 1: Profile position control 3: Profile velocity mode 4: Profile torque mode 6: Homing mode 8: Cyclic synchronous position mode 9: Cyclic synchronous velocity mode A: Cyclic synchronous torque mode
	1-8 (communication status)	-	Displays the status of the slave EtherCAT state machine in the form of characters. 1: Initialization 2: Pre-operational 4: Safe operational 8: Operational
	- CN4 (connection indication)	EtherCAT output connected successfully	Solid OFF: No communication connection is detected in the physical layer.
	- CN3 (connection indication)	EtherCAT input connected successfully	Solid ON: Communication connection is detected in the physical layer.

4.2.4 Parameter Display

SV630N servo drive parameters are divided into 14 groups based on parameter functions. A parameter can be located quickly based on the group it belongs to. See "[7.2 List of Object Groups](#)" to view the parameter list.

■ Display of the parameter group

Display	Name	Description
HXX.YY	Parameter group	XX: Parameter group No. (decimal) YY: Parameter No. within the group (hexadecimal)

For example, H02-00 is displayed as follows.

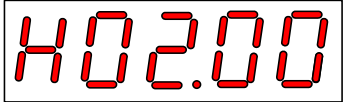
Display	Name	Description
	H02-00	02: Parameter group No. 00: Parameter No. within the group

■ Display of negative numbers and data of different lengths

- 1) Signed number of 4 digits and below or unsigned number of 5 digits and below

Such numbers are displayed in a single page (five LEDs). For signed numbers, the highest bit "-" indicates the negative symbol.

For example, -9999 and 65535 are displayed as follows.

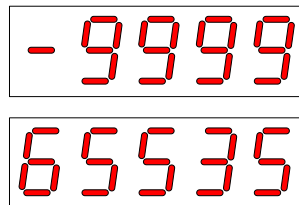

- 2) Signed number of more than 4 digits or unsigned number of more than 5 digits

Such numbers are displayed from low to high digits through several pages with each page displaying five digits. The display mode is shown in the following figure (current page + value on the current page). Hold down  for more than 2s to switch to the next page.

For example, -1073741824 is displayed as follows.

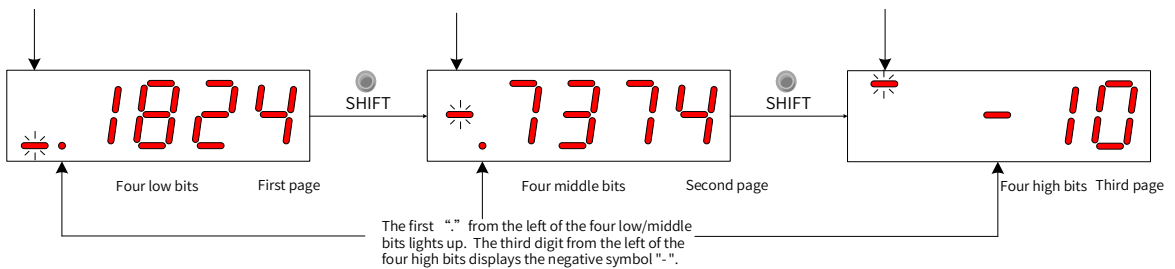

Figure 4-3 Display of "-1073741824"

For example, 1073741824 is displayed as follows.

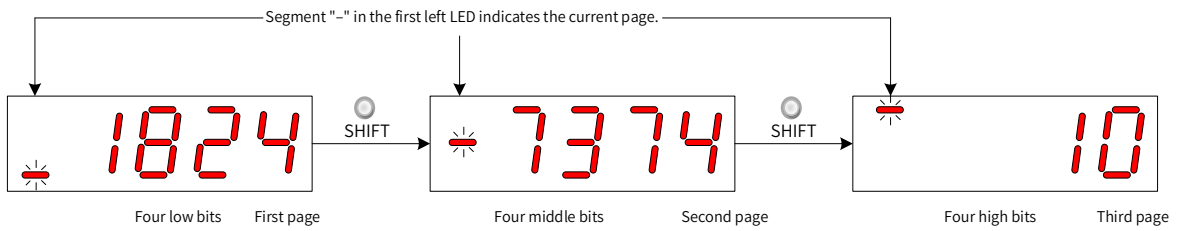

Figure 4-4 Display of "1073741824"

■ Decimal point display

The segment "." of the ones position indicates the decimal point, and this segment does not blink.

Display	Name	Description
	Decimal point	100.0

■ Parameter setting display

Display	Name	Display Condition	Meaning
	Done (parameter setting done)	Parameter setting done	The parameter value is set and stored in the servo drive. The servo drive is ready to perform other operations.
	F.InIt (parameter restored to default setting)	Parameter initialization in progress (H02-31 = 1)	The servo drive is in the process of parameter initialization. After parameter initialization is done, restart the control circuit power supply.
	Error (wrong password)	User password (H02-30) applied and wrong password entered	The password entered is wrong. Enter the password again.
	TunE	One-button tuning enabled	The one-button tuning is in progress.
	FAIL	One-button tuning failed	The one-button tuning failed.

4.2.5 Fault Display

- The keypad can display present or previous faults and warnings. For analysis and solutions to the faults and warnings, see "[6 Troubleshooting](#)".
- When an individual fault or warning occurs, the keypad displays the fault or warning code immediately. When multiple faults or warnings occur, the keypad displays the warning code of the highest level.

- Set the fault to be viewed in H0B-33 (Fault log). View the fault code of the selected fault in H0B-34.
- Set H02-31 (Parameter initialization) to 2 (Clear fault log) to clear the latest 10 faults or warnings saved in the servo drive.

For example, E941.0 is displayed as follows.

Display	Name	Description
	E941.0	E: Fault or warning 941.0: Fault or warning code

4.2.6 Monitored Value Display

Group H0B: Displays parameters used to monitor the operating state of the servo drive.



Set H02-32 (Default keypad display). After the servo motor runs, the keypad switches from the status display mode to the parameter display mode and displays the parameter No. defined by H02-32 in group H0B.



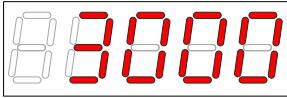
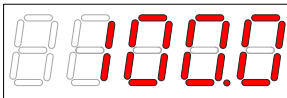
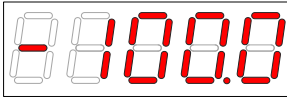



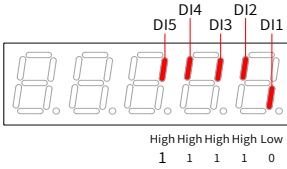
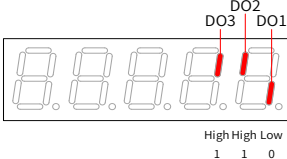
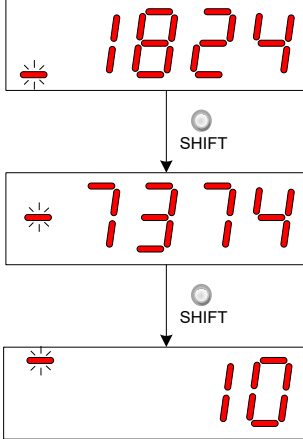

For example, if H02-32 is set to 00, the keypad displays the value of H0B-00 when the motor speed is not 0 RPM.

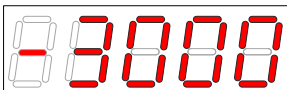
See details of the monitored value display mode in the following table.



Para. No.	Name	Unit	Meaning	Display Example
H0B-00	Motor speed actual value	RPM	Displays the actual value of the motor speed after round-off, which is accurate to 1 RPM.	Display of 3000 RPM:  Display of -3000 RPM: 
H0B-01	Speed reference	RPM	Displays present speed reference of the servo drive.	Display of 3000 RPM:  Display of -3000 RPM: 
H0B-02	Internal torque reference	0.1%	Displays the percentage of the actual motor output torque to the rated motor torque.	Display of 100.0%:  Display of -100.0%: 

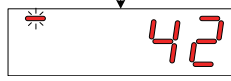
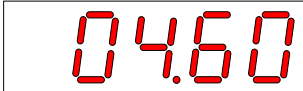

4 Keypad Display and Operations

Para. No.	Name	Unit	Meaning	Display Example
H0B-03	Monitored DI status	-	<p>Displays the level status of DI1 to DI5:</p> <p>Upper LED segment ON: High level (indicated by "1")</p> <p>Lower LED segment ON: Low level (indicated by "0")</p> <p>The value of H0B-03 read using the software tool is a decimal number.</p>	<p>In the case where DI1 input is low level and DI2 to DI5 inputs are high level, the corresponding binary value is 11110, the value of H0B-03 read using the software tool is 0x001E, and the corresponding display status is as follows.</p> 
H0B-05	Monitored DO status	-	<p>Displays the level status of DO1 to DO3:</p> <p>Upper LED segment ON: High level (indicated by "1")</p> <p>Lower LED segment ON: Low level (indicated by "0")</p> <p>The value of H0B-05 read using the software tool is a decimal number.</p>	<p>In the case where DO1 is low level and DO2 to DO3 are high level, the corresponding binary value is 110, the value of H0B-05 read using the software tool is 0x0006, and the corresponding display status is as follows.</p> 
H0B-07	Absolute position counter (32-bit decimal value)	Reference unit	Displays the absolute position of the motor (reference unit).	<p>Display of 1073741824 in reference unit:</p> 
H0B-09	Mechanical angle	0.1°	Displays the present mechanical angle of the motor.	<p>Display of 360.0°:</p> 
H0B-10	Rotation angle (Electrical angle)	0.1°	Displays the present electrical angle of the motor.	<p>Display of 360.0°:</p> 

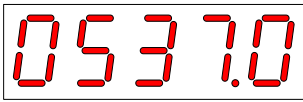
Para. No.	Name	Unit	Meaning	Display Example
H0B-11	Speed information corresponding to the input position reference	RPM	Displays the speed corresponding to the position reference in an individual control cycle.	Display of 3000 RPM:  Display of -3000 RPM: 
H0B-12	Average load rate	0.1%	Displays the percentage of the average load torque to the rated torque of the motor.	Display of 100.0%: 
H0B-15	Encoder position deviation counter (displayed in 32-bit decimal)	Encoder unit	Encoder position deviation = Sum of input position references (encoder unit) - Sum of pulses fed back by the encoder (encoder unit)	Display of 10000 in encoder unit:  SHIFT 
H0B-17	Feedback pulse counter (displayed in 32-bit decimal)	Encoder unit	Counts and displays the number of servo motor encoder pulses (encoder unit). Note: When an absolute motor is used, H0B-17 only shows the low 32-bit value of the motor position feedback. To obtain the actual motor position feedback, view H0B-77 and H0B-79.	Display of 1073741824 in encoder unit:  SHIFT  SHIFT 
H0B-19	Total power-on time (displayed in 32-bit decimal)	0.1s	Counts and displays the total power-on time of the servo drive.	Display of 429496729.5s:  Hold down SHIFT  Hold down SHIFT 
H0B-24	RMS value of phase current	0.1 A	Displays the RMS value of the servo motor phase current.	Display of 4.60 A: 

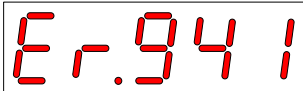
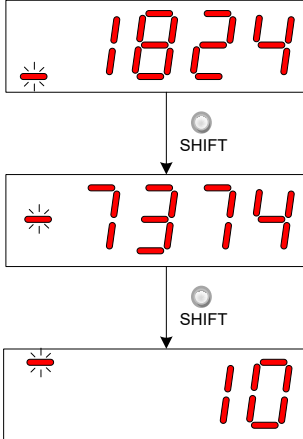

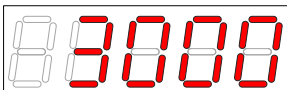
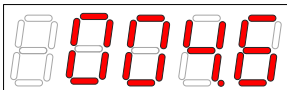
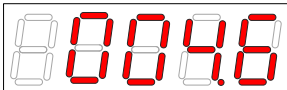
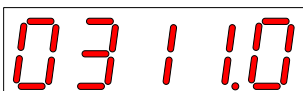

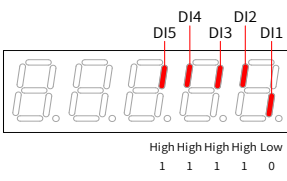
4 Keypad Display and Operations

Para. No.	Name	Unit	Meaning	Display Example
H0B-26	Bus voltage	0.1 V	Displays the main circuit DC bus voltage between terminals P and -.	<p>Display of 311.0 V rectified from 220 VAC:</p>  <p>Display of 537.0 V rectified from 380 VAC:</p> 
H0B-27	Power module temperature	°C	Displays the temperature of the power module inside the servo drive.	<p>Display of 27°C :</p> 
H0B-33	Fault log	-	<p>Displays the previous fault to be viewed.</p> <p>0: Present fault 1: Last fault 2: 2nd to last fault ... 9: 9th to last fault</p>	<p>0-Display of present fault:</p> 
H0B-34	Fault code of the selected fault	-	<p>Displays the fault code of the fault defined by H0B-33.</p> <p>When no fault occurs, H0B-34 displays "Er.000".</p>	<p>If H0B-33 = 0, H0B-34 = Er.941, the present fault code will be 941. Corresponding display:</p> 
H0B-35	Time stamp of the selected fault	s	<p>Displays the total operating time of the servo drive when the fault defined by H0B-33 occurs.</p> <p>When there is no fault, H0B-35 displays "0".</p>	<p>If H0B-34 = Er.941, and H0B-35 = 107374182.4, the present fault code will be 941 and the total operating time of the servo drive is 107374182.4s when the fault occurs.</p> 

Para. No.	Name	Unit	Meaning	Display Example
H0B-37	Motor speed upon occurrence of the selected fault	RPM	Displays the servo motor speed when the fault defined by H0B-33 occurred. When there is no fault, H0B-37 displays "0".	<p>Display of 3000 RPM:</p>  <p>Display of -3000 RPM:</p> 
H0B-38	Motor phase U current upon occurrence of the selected fault	0.1 A	Displays the RMS value of phase U winding current of the servo motor when the fault defined by H0B-33 occurred. When there is no fault, H0B-38 displays "0".	<p>Display of 4.60 A:</p> 
H0B-39	Motor phase V current upon occurrence of the selected fault	0.1 A	Displays the RMS value of phase V winding current of the servo motor when the fault defined by H0B-33 occurred. When there is no fault, H0B-39 displays "0".	<p>Display of 4.60 A:</p> 
H0B-40	Bus voltage upon occurrence of the selected fault	V	Displays the DC bus voltage of the main circuit when the fault defined by H0B-33 occurred. When there is no fault, H0B-40 displays "0".	<p>Display of 311.0 V rectified from 220 VAC:</p>  <p>Display of 537.0 V rectified from 380 VAC:</p> 
H0B-41	Input terminal status upon occurrence of the selected fault	-	Displays the electrical status of the five DIs when the fault defined by H0B-33 occurred. The viewing method is the same as that of H0B-03. When there is no fault, all the DIs are low level, as displayed in H0B-41, and the corresponding hexadecimal value is "0".	<p>In the case where the value of H0B-41 read using the software tool is 0x0001, the corresponding binary code will be 0000 0000 0000 0001.</p> 

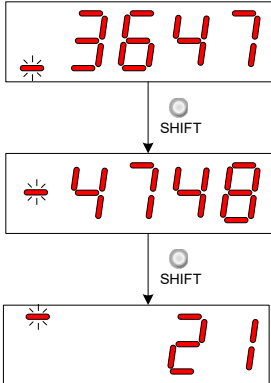
4 Keypad Display and Operations

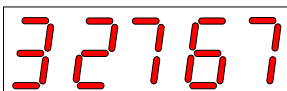
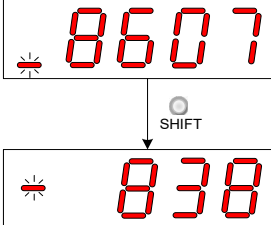
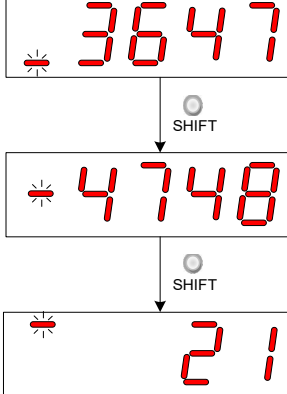
Para. No.	Name	Unit	Meaning	Display Example
H0B-43	Output terminal status upon occurrence of the selected fault	-	<p>Displays the electrical status of the three DOs when the fault defined by H0B-33 occurred.</p> <p>The viewing method is the same as that of H0B-05.</p> <p>When there is no fault, all the DOs are low level, as displayed in H0B-43, and the corresponding decimal value is "0".</p>	<p>Display of H0B-43 = 0x0003:</p>
H0B-53	Position deviation counter (displayed in 32-bit decimal)	Reference unit	<p>Position deviation = Sum of input position references (reference unit) - Sum of pulses fed back by the encoder (reference unit)</p>	<p>Display of 10000 in reference unit:</p>
H0B-55	Motor speed actual value	0.1 RPM	<p>Displays the actual value of the motor speed, which is accurate to 0.1 RPM.</p>	<p>Display of 3000.0 RPM:</p> <p>Display of -3000.0 RPM:</p>
H0B-57	Control circuit voltage	0.1 V	<p>Displays the DC voltage of the control circuit.</p>	<p>Display of 12.0 V:</p>

Para. No.	Name	Unit	Meaning	Display Example
H0B-58	Mechanical absolute position (low 32 bits)	Encoder unit	Displays the mechanical absolute position (low 32 bits) when an absolute encoder is used.	Display of 2147483647 in encoder unit: 
H0B-60	Mechanical absolute position (high 32 bits)	Encoder unit	Displays the mechanical absolute position (high 32 bits) when an absolute encoder is used.	Display of "-1" in encoder unit: 
H0B-70	Number of absolute encoder revolutions	Rev	Displays the present number of revolutions of an absolute encoder.	Display of 32767: 
H0B-71	Single-turn position feedback of the absolute encoder	Encoder unit	Displays the single-turn position feedback of the absolute encoder.	Display of 8388607 in encoder unit: 
H0B-77	Absolute encoder position (low 32 bits)	Encoder unit	Displays the absolute position (low 32 bits) of the motor when the absolute encoder is used.	Display of 2147483647 in encoder unit: 
H0B-79	Absolute encoder position (high 32 bits)	Encoder unit	Displays the absolute position (high 32 bits) of the motor when an absolute encoder is used.	Display of "-1" in encoder unit: 

Para. No.	Name	Unit	Meaning	Display Example
H0B-81	Single-turn position feedback of the load in rotation mode (low 32 bits)	Encoder unit	Displays the position feedback of the mechanical load (low 32 bits) when the absolute system works in the rotation mode.	Display of 2147483647 in encoder unit:
H0B-83	Single-turn position feedback of the load in rotation mode (high 32 bits)	Encoder unit	Displays the position feedback of the mechanical load (high 32 bits) when the absolute system works in the rotation mode.	Display of 1 in encoder unit:
H0B-85	Single-turn position of the load in rotation mode	Reference unit	Displays the absolute mechanical position when the absolute system works in the rotation mode.	Display of 1073741824 in reference unit:

4.3 Parameter Settings

Parameter settings can be performed through the keypad. For details on parameters, see "[7.2 List of Object Groups](#)". The following figure shows how to change from position control mode to speed control mode after the power supply is switched on.

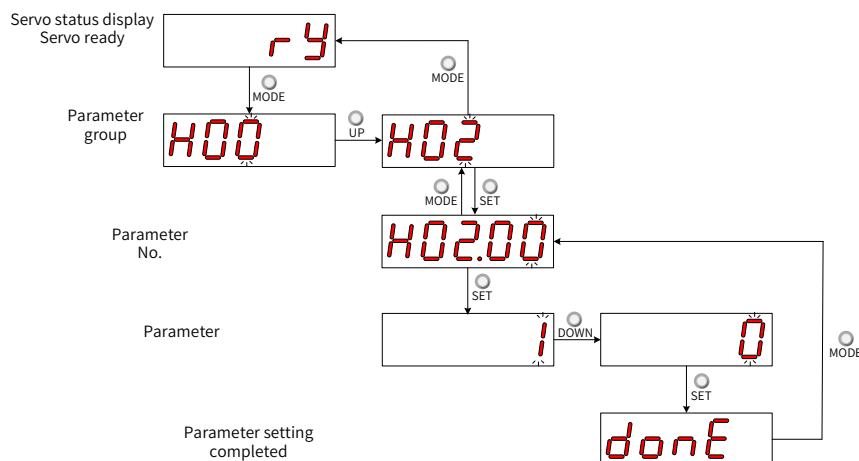



Figure 4-5 Procedure for parameter setting

-  : Used to switch the keypad display mode and return to the previous menu.
- "▲"/"▼": Used to increase or decrease the value of the blinking digit.
- "◀◀": Used to shift the blinking digit.
-  : Used to save present setpoint or switch to the next menu.

After setting the parameters, that is, "Done" is displayed on the keypad, press  to return to parameter group display (interface of "H02-00").

4.4 User Password

After the user password (H02-30) is enabled, only the authorized user can set parameters; other users can only view the parameter.

- Setting the user password

The following figure shows how to set the password to "00001".

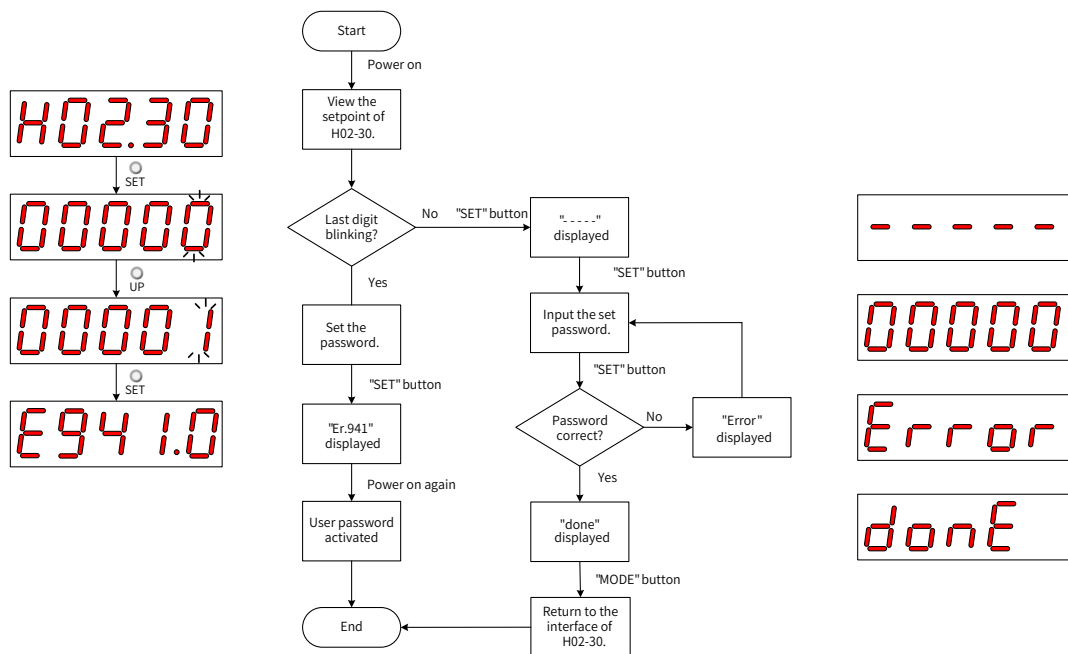

Figure 4-6 Procedure for user password setting

To change the user password, input the present password first to authorize the access to parameter setting, and then enter H02-30 again to set a new password according to the method described in the preceding figure.



NOTE



If the last digit does not blink, access to parameters is password protected. If the last digit blinks, no password is set or a correct password has been entered.

- Canceling user password

Enter the set user password, and set H02-30 to "00000" to cancel the user password.

4.5 General Functions

4.5.1 Jog

 CAUTION	
	The jog function requires the S-ON signal to be deactivated. Otherwise, jogging cannot be executed.

Users can perform trial running on the servo motor and the servo drive through jogging.

■ Operating process

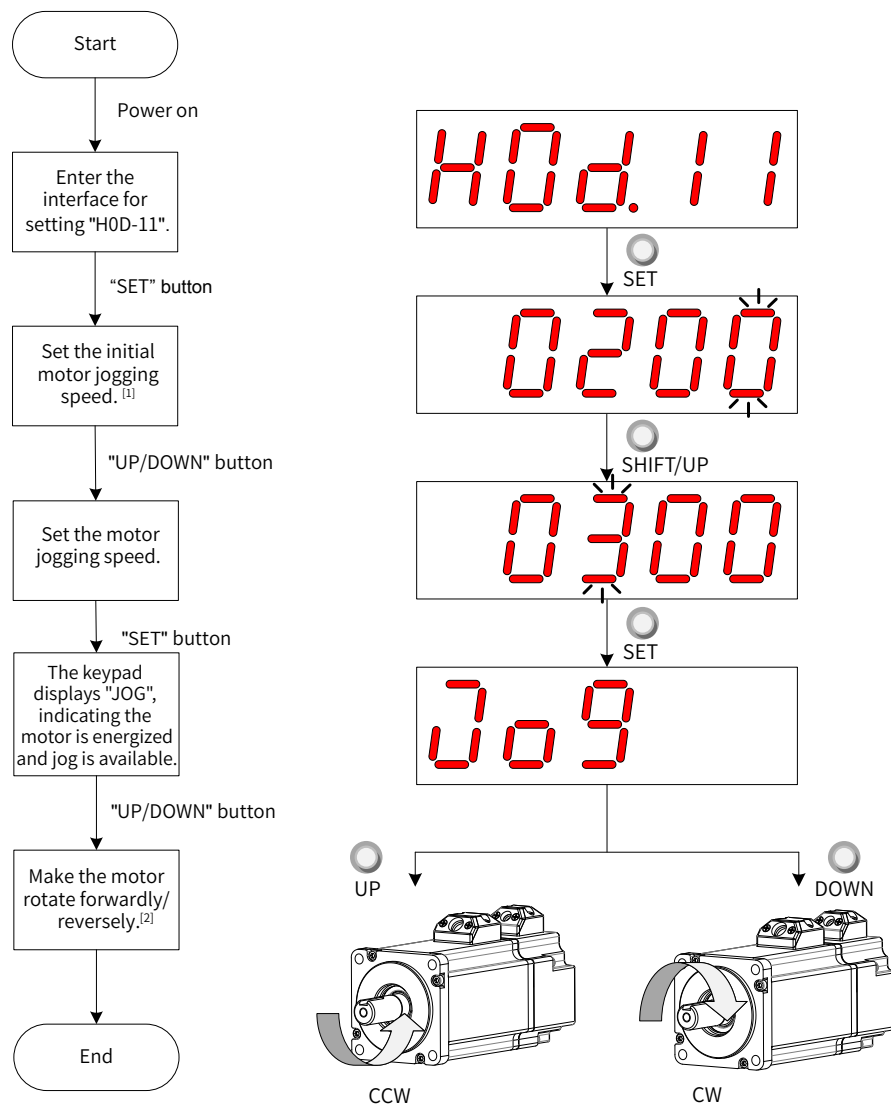



Figure 4-7 Procedure for setting the jog function

- [1] Press ▲ or ▼ to increase or decrease the motor jogging speed. After exiting from the jog mode, the motor returns to the initial speed.
- [2] Press ▲ or ▼ to make the servo motor rotate in forward or reverse direction. After you release the button, the servo motor stops immediately.

■ Exiting from jog

Press  to exit from the jog status and return to the previous menu.

4.5.2 Forced DI/DO Signals

There are five DI signals and three DO signals on the CN1 terminal. Users can assign DI/DO functions and logics to parameters in group H03/H04 using the keypad (or host controller communication), so that the host controller can control corresponding functions through the DI/DO signal output by the servo drive.

The servo drive also offers forced DI/DO function. The forced DI can be used to test the DI function of the servo drive, and the forced DO can be used to check the DO signal connection between the host controller and the servo drive.

■ Definition of DI/DO functions

Code	Name	Function	Description	Remarks
Consisting of two digits which indicate DI terminal function				
Functions of DI signals				
01	S-ON	Servo ON	Inactive - Servo motor disabled in local mode Active - Servo motor enabled in local mode	The S-ON function is active only in the non-bus control mode. The corresponding DI logic must be level-triggered.
02	ALM-RST	Fault reset	Active: Fault reset under local mode Inactive: Fault not reset under local mode	This function is active only in the non-bus control mode. It is recommended the corresponding DI logic be level-triggered.
14	P-OT	Positive limit switch	Active - Forward drive inhibited Inactive - Forward drive permitted	Overtravel prevention applies when the mechanical movement is beyond the movable range. It is recommended the corresponding DI logic be level-triggered.
15	N-OT	Negative limit switch	Active - Reverse drive inhibited Inactive - Reverse drive permitted	Overtravel prevention applies when the mechanical movement is beyond the movable range. It is recommended the corresponding DI logic be level-triggered.
31	HomeSwitch	Home switch	Inactive - Mechanical load beyond the home switch range Active - Mechanical load within the home switch range	The corresponding DI logic must be level-triggered.
34	EmergencyStop	Emergency stop	Active: Position locked after stopping at zero speed Inactive: Current running status not affected	It is recommended the corresponding DI logic be level triggered.
38	TouchProbe1	Touch probe 1	Inactive - Probe not triggered Active - Probe can be triggered	The probe logic is related only to the probe function (60B8h).
39	TouchProbe2	Touch probe 2	Inactive - Probe not triggered Active - Probe can be triggered	The probe logic is related only to the probe function (60B8h).
Functions of DO signals				

Code	Name	Function	Description	Remarks
01	S-RDY	Servo ready	Active - Servo ready Inactive - Servo not ready	The servo drive is ready to run.
02	TGON	Motor rotating	Inactive - Absolute value of filtered motor speed smaller than the value of H06-16. Active - Absolute value of filtered motor speed reaching the value of H06-16.	-
09	BRK	Brake output	Active: Brake signal outputted Inactive: Brake signal not outputted	-
10	WARN	Warning	Active - Warning occurred on the servo drive Inactive - No warning occurred on the servo drive or the warning has been reset	-
11	ALM	Fault	Active - Fault occurred on the servo drive Inactive - No fault occurred on the servo drive or the fault has been reset	-
25	CMP	Position comparison	Active: Servo drive passing the target position comparison point Inactive: Servo drive not passing the target position comparison point	-
32	EDM	Safety status	Active: STO function triggered Inactive: STO function not triggered	The EDM outputs active signals only when the 24 V input voltages for STO1 and STO2 are disconnected simultaneously.

1 Forced DI function

When this function is enabled, all DI levels are controlled by H0D-18 (Forced DI value), which is not related to the external DI signal status.

■ Operating process

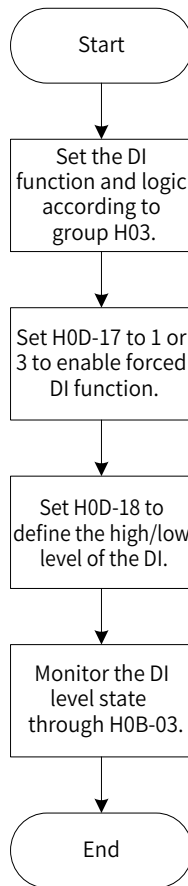

Figure 4-8 Procedure for setting forced DI function

☆ Related parameter

Parameter No.		Name	Value Range	Function	Setting Condition	Effective Time	Default
Keypad Side	Software Tool Side						
H0D-17	200D-12h	Forced DI/DO selection	0: No operation 1: Forced DI enabled, forced DO disabled 2: Forced DO enabled, forced DI disabled 3: Forced DI and DO enabled 4: EtherCAT forced DO	This parameter is used to select the forced DI/DO function.	During running	Immediately	0

H0D-18 is used to set the forced DI level. The display value is a hexadecimal. After the hexadecimal is converted to a binary, the number "1" indicates high level and the number "0" indicates low level.

The DI logic is defined by parameters in group H03. The DI level status is monitored by H0B-03 and displayed on the keypad. The value of H0B-03 (Monitored DI signal) read through the software tool is a hexadecimal.

■ Example

To activate the function assigned to DI1 and deactivate functions assigned to DI2...DI5, set as follows (logic of all the five DIs being "active low"):

As the number "1" indicates high level and "0" indicates low level, the binary value is "11110", which corresponds to the hexadecimal number "1E". Therefore, set the value of H0D-18 (Forced DI value) to "1E" through the keypad.

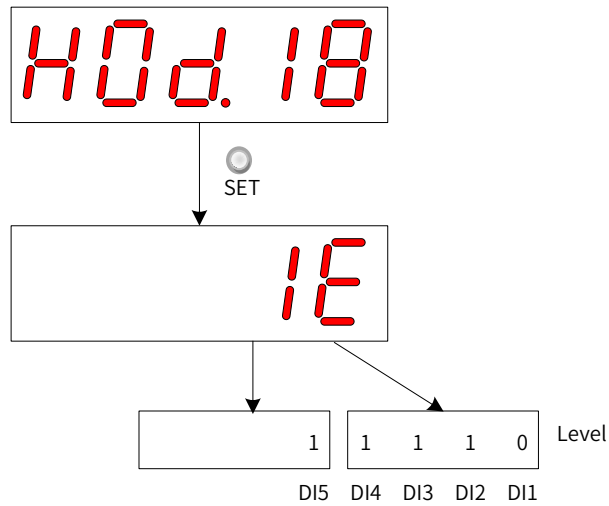

Figure 4-9 Description of the setpoint of H0D-18

Monitoring the DI level status through H0B-03:

If the DI function is normal, the display value of H0B-03 is always the same as that of H0D-18.

In this case, DI1 is displayed as low level and DI2 to DI5 are displayed as high level on the keypad, and the value of H0B-03 read through the software tool is 1E (hexadecimal). The keypad displays as follows.

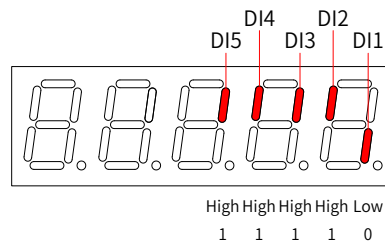



Figure 4-10 DI level status corresponding to H0B-03

■ Exit

The forced DI function is not retentive upon power-off. Normal DIs apply after restart, or you can set H0D-17 (Forced DI/DO selection) to 0 (No operation) to return to the normal DI mode.

2 Forced DO function

After this function is enabled, all DO levels are controlled by H0D-19 (Forced DO value).

 CAUTION	
	<p>In cases where the servo motor is used in vertical motion, if the brake output signal (FunOUT.9: BK, brake output) is used, the brake is released and the load may fall. Therefore, take protective measures on the machine to prevent falling.</p>

■ Operating process

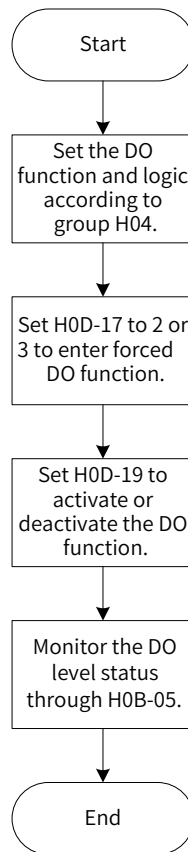

Figure 4-11 Procedure for setting forced DO function

H0D-19 (Forced DO value) is used to set whether the DO function is active. The keypad displays the value in hexadecimal. After the hexadecimal is converted to a binary, the number "1" indicates the DO function is active and "0" indicates the DO function is inactive.

The DO logic is defined by parameters in group H04. The DO level status is monitored by H0B-05 and displayed on the keypad. The value of H0B-05 (Monitored DO signal) read through the software tool is a hexadecimal.

Example: To activate the DO function assigned to DO1 and deactivate DO functions assigned to DO2...DO3, set as follows:

As the number "1" indicates the DO function is active and "0" indicates the DO function is inactive, the binary value is "110", which corresponds to the hexadecimal number "6". Therefore, set H0D-19 (Forced DO value) to 6 through the keypad.

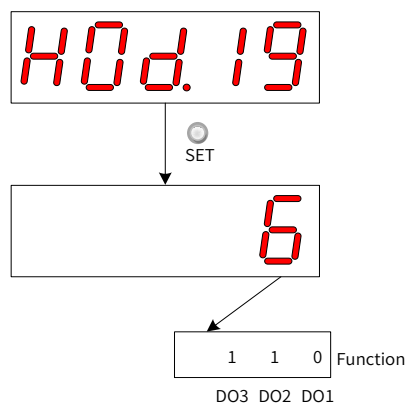

Figure 4-12 Description of the setpoint of H0D-19

Monitoring the DO level status through H0B-05

If the logics of DO1 to DO3 are "active low", then DO1 is high level and DO2 to DO3 are low level, and the corresponding binary number is "001". In this case, the value of H0B-05 (Monitored DO signal) read through the software tool is 1 (decimal). The keypad displays as follows.

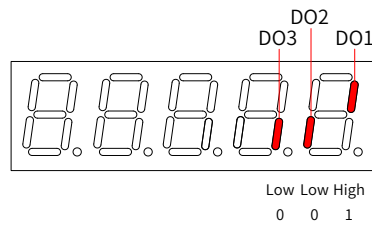

Figure 4-13 Display of H0B-05 when all DOs are "active low"

If the logics of DO1 to DO3 are "active high", then DO1 is low level and DO2 to DO3 are high level, the corresponding binary number is "110", and the value of H0B-05 (Monitored DO signal) read through the software tool is 6 (decimal). The keypad displays as follows.

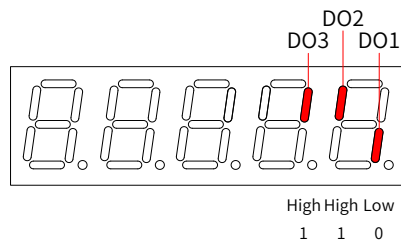

Figure 4-14 Display of H0B-05 when all DOs are "active high"

■ Exit

The forced DO function is not retentive upon power-off. Normal DOs apply after restart, or you can set H0D-17 (Forced DI/DO selection) to 0 (No operation) to return to the normal DO mode.

3 EtherCAT-controlled forced DO function

After this function is enabled, all DO signal levels are controlled by 60FE-01h (Physical output).

In cases where the servo motor is used in vertical motion, if the brake output signal (FunOUT.9: BK, brake output) is used, the brake is released and the load may fall. Therefore, take protective measures to prevent falling.

■ Operating process

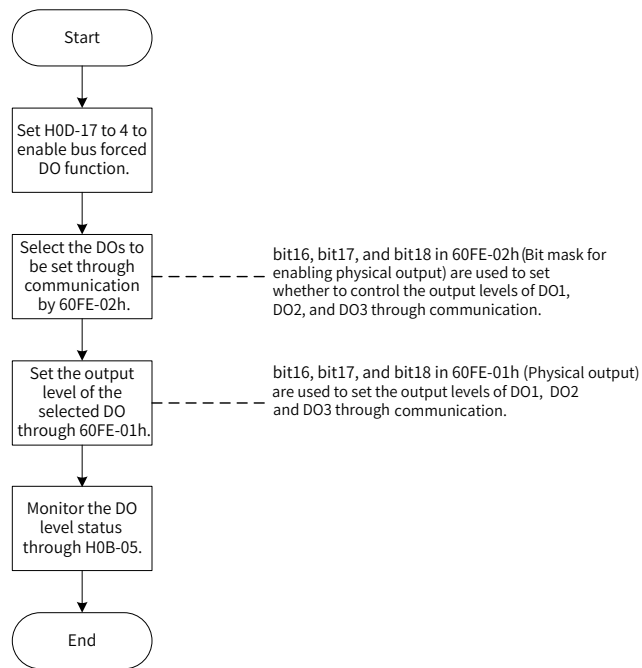

Figure 4-15 Procedure for setting forced DO through EtherCAT

When 200D-12h is set to 4, 60FE (Digital output) can be used to set the DO level through EtherCAT.

Bit	Related DO	Physical Output Enable: 60FE-02h	Physical Output: 60FE-01h
16	DO1	1: DO1 forced output enabled	DO1 forced output (0: OFF, 1: ON)
17	DO2	1: DO2 forced output enabled	DO2 forced output (0: OFF, 1: ON)
18	DO3	1: DO3 forced output enabled	DO3 forced output (0: OFF, 1: ON)

When 200D-12h is set to 4 and any bit among bit16 to bit18 of 60FE-02h is set to 1, the corresponding forced DO is OFF.

The DO level status is monitored by H0B-05 and displayed on the keypad. The value of H0B-05 (Monitored DO signal) read through the software tool is a hexadecimal.

Example: To make the output level of DO1 to DO3 be forcibly set by the EtherCAT bus, in which DO1 outputs low level and DO2 to DO3 output high level, set as follows:

Set 200D-12h to 4, 60FE-02h to 0x00070000 and 60FE-01 to 0x00060000, and monitor the DO level status through H0B-05 (Monitored DO signal). The keypad displays as follows.

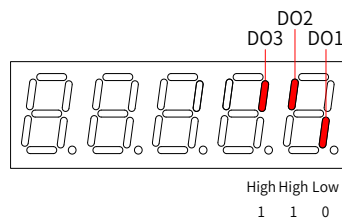

Figure 4-16 Display of H0B-05 when DO signals are controlled by EtherCAT

■ Exit

The EtherCAT-controlled forced DO function is not retentive upon power-off. Normal DOs apply after restart, or you can set H0D-17 (Forced DI/DO selection) to 0 (No operation) to return to the normal DO mode.

5 Commissioning and Operation

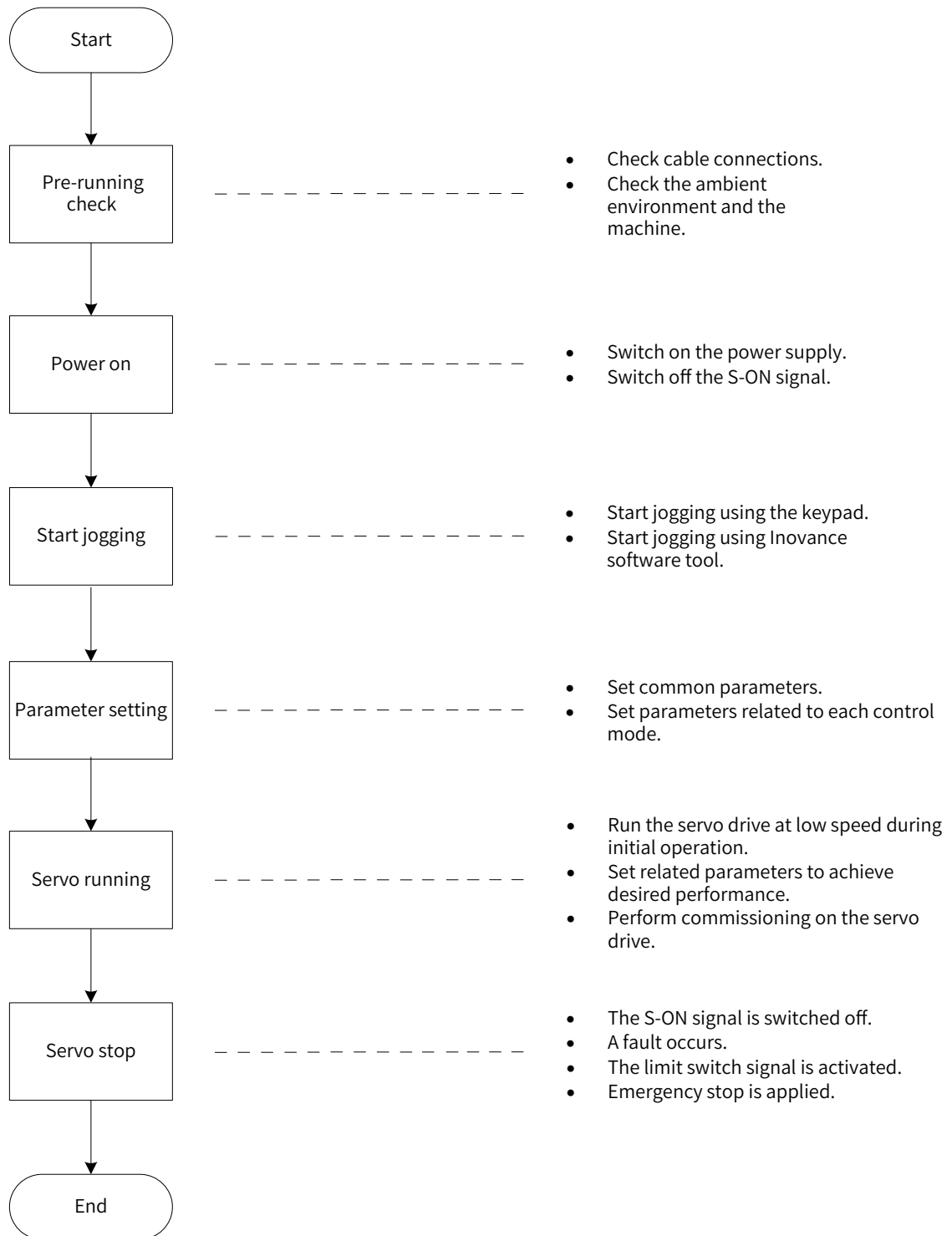

Figure 5-1 Flowchart for setting the servo drive

5.1 Pre-running Check

Check the following items before operating the servo drive and the servo motor.

Table 5-1 Pre-running checklist

Record	No.	Description
Wiring		
<input type="checkbox"/>	1	Power input terminals of the servo drive are connected properly.
<input type="checkbox"/>	2	The servo motor UVW cables are connected in the correct phase sequence at both ends.
<input type="checkbox"/>	3	No short circuit exists in the power input terminals or the main circuit output terminals (U, V, W) of the servo drive.
<input type="checkbox"/>	4	The control signal cables are connected properly. External signal cables such as brake and overtravel prevention signals are connected properly.
<input type="checkbox"/>	5	The servo drive and the servo motor are grounded properly.
<input type="checkbox"/>	6	The stress on cables is within the permissible range.
<input type="checkbox"/>	7	The connecting terminals are well insulated.
Environment and Mechanical Conditions		
<input type="checkbox"/>	1	No unwanted objects (such as the cable end or metal filings) which may cause short circuit are present inside or near the servo drive.
<input type="checkbox"/>	2	The servo drive and the external regenerative resistor are placed on incombustible objects.
<input type="checkbox"/>	3	The servo motor installation and the shaft and mechanical connections are reliable.
<input type="checkbox"/>	4	The servo motor and the machine that the servo motor is connected to are ready to run.

5.2 Power-on

■ Switching on the input power supply

The input terminals for single-phase 220 V power supplies are L1 and L2.

The input terminals for three-phase power supplies are L1/L2/L3 or L1C/L2C (control circuit power input terminals) and R/S/T (main circuit power input terminals)

After the input power supply is switched on, if the bus voltage indicator is in normal status and the keypad displays "reset" → "ry" in sequence, the servo drive is ready to run and waits for the S-ON signal from the host controller.

If the keypad keeps displaying "nr", see ["6 Troubleshooting"](#) for solutions.

If the keypad displays the fault code, see ["6 Troubleshooting"](#) for solutions.

■ Deactivating the S-ON signal

Switch the servo state machine and deactivate the S-ON signal sent from the host controller.

Deactivate the DI enable signal or the internal auxiliary function enable signal.

5.3 Jogging

Perform jogging to check whether the servo motor rotates properly without unusual vibration or noise. The jog function can be started using the keypad (jogging in the speed mode/jogging in the position mode) or Inovance software tool (jogging in the speed mode).



NOTE

The acceleration/deceleration time constant of the speed/position reference can be set through H06-12 (2006-0Dh) in case of jogging mode.

■ Using the keypad (jogging in the speed mode)

Enter jogging in the speed mode by setting H0D-11 through the keypad. The keypad displays the default jogging speed, which can be modified by pressing / . Press to enter the jogging status. The keypad displays "JOG". Power on the servo motor, and hold down / to switch between forward and reverse jogging as needed. Press to exit from the jogging mode.

■ Using Inovance software tool (jogging in the speed mode)

Open the "Speed JOG" interface in the software tool and set the jog speed. After switching the servo status to ON, click the forward/reverse arrow displayed on the interface to switch between forward and reverse jog as needed.

■ Using the keypad (jogging in the position mode)

Enter jogging in the position mode by setting H0D-08 through the keypad. The keypad displays the default jogging speed, which can be modified by pressing / . Press to enter the jogging status. The keypad displays "JOG-P". Power on the servo motor, and hold down / to switch between forward and reverse jogging as needed. Press to exit from the jogging mode.

☆ Related parameters:

H06-12	Name	Acceleration ramp time of jog speed			Setting Condition & Effective Time	Any condition & Immediately	Data Structure	-	Data Type	Uint16
2006-0Dh	Access	RW	Mapping	Yes	Related Mode	All	Data Range	0 to 65535 (ms)	Default	10
Used to set the time constant for the servo motor to accelerate from 0 RPM to 1000 RPM.										

5.4 General Parameter Settings

5.4.1 Direction of Rotation

Set H02-02 (2002-03h) (Direction of rotation) to change the motor direction of rotation without changing the polarity of the input reference.

☆ Related parameters:

H02-02	Name	Direction of rotation			Setting Condition & Effective Time	At stop & Next power-on	Data Structure	-	Data Type	Uint16
2002-03h	Access	RW	Mapping	-	Related Mode	All	Data Range	0-1	Default	0

Defines the forward direction of the motor when viewed from the motor shaft side.

Value	Rotation direction	Remarks
0	CCW as the forward direction	Defines the CCW direction as the forward direction when a forward run command is received, indicating the motor rotates in the CCW direction when viewed from the motor shaft side.
1	CW as the forward direction	Defines the CW direction as the forward direction when a forward run command is received, indicating the motor rotates in the CW direction when viewed from motor shaft side.

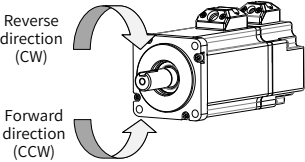

Changes in the setpoint of H02-02 (2002-03h) do not affect the pulse output form or the positive/negative attribute of monitoring parameters.

The "Forward drive" and direction of rotation in the overtravel prevention function are the same as the settings in H02-02 (2002-03h).

5.4.2 Brake Settings

The brake is used to prevent the servo motor shaft from rotating when the servo drive is in the non-operating state. This is to keep the motor and the mechanical load in locked positions.

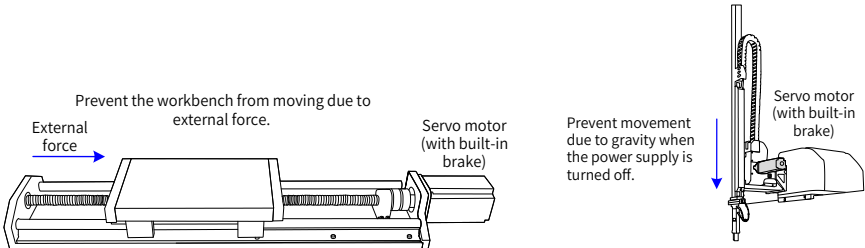



Figure 5-2 Application of the motor brake

 CAUTION	
	<ul style="list-style-type: none"> ◆ Use the built-in brake for position-lock only in the stop state. ◆ The brake coil has no polarity. ◆ After the servo motor stops, switch off the S-ON signal. ◆ When the servo motor with built-in brake runs, the brake may generate a clattering sound. Such sound is normal. ◆ When brake coils are energized (the brake is released), magnetic flux leakage may occur at the shaft end. Pay special attention when using magnetic sensors around the servo motor.

1 Wiring of the brake

The motor brake input signal is connected without polarity differentiation. You need to prepare a 24 V power supply. The following figure shows the standard wiring of the brake signal (BK) and motor brake power supply.

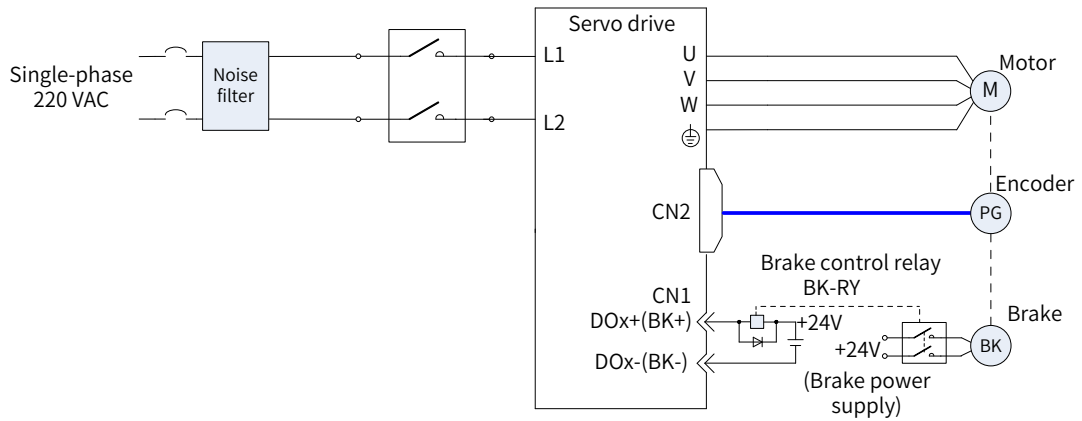

Figure 5-3 Wiring of the motor brake

Pay attention to the following precautions during wiring:

The length of the motor brake cable is subject to the voltage drop caused by cable resistance. The input voltage must be at least 21.6 V to enable the brake to work properly. The following table lists brake specifications of Inovance servo motors.

Table 5-2 Brake specifications

Motor Model	Holding Torque (N·m)	Supply Voltage (V _{DC}) ±10%	Rated Power (W)	Coil Resistance (Ω) (±7%)	Excitation Current (A)	Apply Time (ms)	Release Time (ms)	Backlash (°)
MS1H1-05B/10B	0.32	24	6.1	94.4	0.25	≤ 40	≤ 20	≤ 1.5
MS1H1-20B/40B	1.5		7.6	75.79	0.32	≤ 60	≤ 20	≤ 1.5
MS1H4-40B	3.2		10	57.6	0.42	≤ 60	≤ 40	≤ 1.0
MS1H1/H4-75B			19.4	29.7	0.81	≤ 120	≤ 60	≤ 0.5
MS1H3-85B/13C/18C	12	24	23	25	0.96	≤ 85	≤ 30	≤ 0.5
MS1H2-10C/15C/20C/25C	8		27	21.3	1.13	≤ 100	≤ 60	≤ 0.5
MS1H2-30C/40C/50C	16		40	14.4	1.67	≤ 200	≤ 100	≤ 0.5
MS1H3-29C/44C/55C/75C	50							

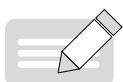

NOTE

- ◆ Do not share the same brake power supply with other devices. This is to prevent brake malfunction due to voltage or current drop resulted from other working devices.
- ◆ It is recommended to use cables of 0.5 mm² and above.

2 Brake software setting

For the servo motor with brake, allocate DO function 9 (FunOUT.9: BK, brake output) to a certain DO (DO3 by default), and set the active logic of this DO.

Related DO function

Function No.	Name	Function	Description
FunOUT.9	BK	Brake output	Inactive: The brake power supply is switched off and the brake applies. In this case, the motor is locked. Active: The brake power supply is switched on and the brake is released. In this case, the motor can rotate.

Depending on the present state of the servo drive, the working time sequence of the brake mechanism can be divided into the following: brake time sequence under normal state and brake time sequence under fault state.

3 Brake time sequence under normal state



The brake time sequence under normal state is divided into the following:

Motor at a standstill: The actual motor speed is less than 20 RPM.

Motor rotating: The actual motor speed is equal to or higher than 20 RPM.

■ Motor at a standstill

If the S-ON signal is OFF, and the present motor speed is less than 20 RPM, the servo drive acts according to the brake time sequence for the motor at a standstill.

 CAUTION	
	<ul style="list-style-type: none"> ◆ When the brake output signal changes from OFF to ON, do not input a position/speed/torque reference within the time defined by 2009-0Ah/2000-34h. Otherwise, reference loss or operation error may occur. ◆ When the motor drives a vertical axis, the load may move slightly due to the gravity or external force. For the motor at a standstill, if the S-ON signal is off, the brake output will be off immediately. However, within the time defined by H02-10 (2002-0Bh), the motor is still energized to prevent the mechanical load from moving due to the gravity or external force.

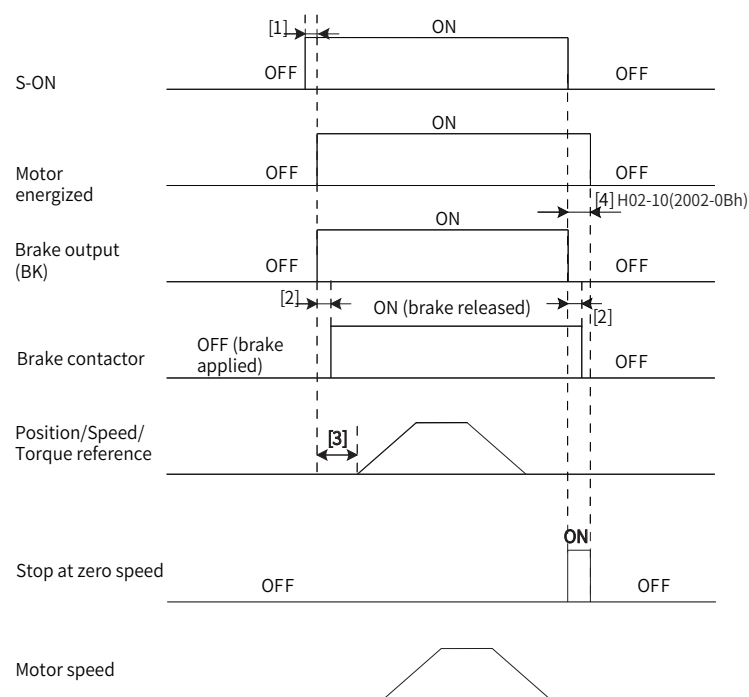

Figure 5-4 Brake time sequence for motor at a standstill

- [1] For the brake delay time, see ["4 Keypad Display and Operations"](#) for details.
- [2] The time interval from the moment when brake output is on to the moment when the command is input must be longer than the time defined by 2009-0Ah/2000-34h.
- [3] For the motor at a standstill (motor speed less than 20 RPM), when the S-ON signal is off, the brake output will be off immediately. You can set the delay from brake output OFF to motor de-energized through 2002-0Bh.



☆ Related parameters:

H02-09	Name	Delay from brake output ON to command received			Setting Condition & Effective Time	Any condition & Immediately	Data Structure	-	Data Type	Uint16
2002-0Ah	Access	RW	Mapping	-	Related Mode	All	Data Range	0-500 (ms)	Default	250
<p>Defines the delay from the moment the brake output signal is on to the moment when the servo drive starts to receive input commands after power-on.</p> <p>Within the time defined by 2002-0Ah, the servo drive does not receive position/speed/torque references.</p>										

H02-10	Name	Delay from brake output OFF to motor de-energized			Setting Condition & Effective Time	Any condition & Immediately	Data Structure	-	Data Type	Uint16
2002-0Bh	Access	RW	Mapping	-	Related Mode	All	Data Range	50-1000 (ms)	Default	150
<p>Defines the delay from the moment the brake output signal is off to the moment when the motor enters de-energized status.</p>										

■ Motor rotating

If the S-ON signal changes from ON to OFF and the present motor speed is equal to or higher than 20 RPM, the servo drive acts according to the brake time sequence for the motor in the rotating state.

	
	<ul style="list-style-type: none"> ◆ When S-OFF changes to S-ON, do not input a position/speed/torque reference within the time defined by 2009-0Ah/2000-34h. Otherwise, reference loss or operation error may occur. ◆ If the S-ON signal is off during motor rotating, the servo motor enters ramp-to-stop state as defined by 6085h. The brake output signal will be off only after one of the following conditions is met: <ol style="list-style-type: none"> 1) The motor has decelerated to the value defined by 2002-0Ch (Motor speed threshold at brake output OFF in rotation state) when the time defined by 2002-0Dh (Delay from S-ON OFF to brake output OFF in rotation state) is not reached. 2) The time defined by 2002-0Dh is reached, but the motor speed is still higher than the value of 2002-0Ch. ◆ After the brake output signal changes from ON to OFF, the motor stays energized within the time defined by 2002-0B to prevent the mechanical load from moving due to the gravity or external force.

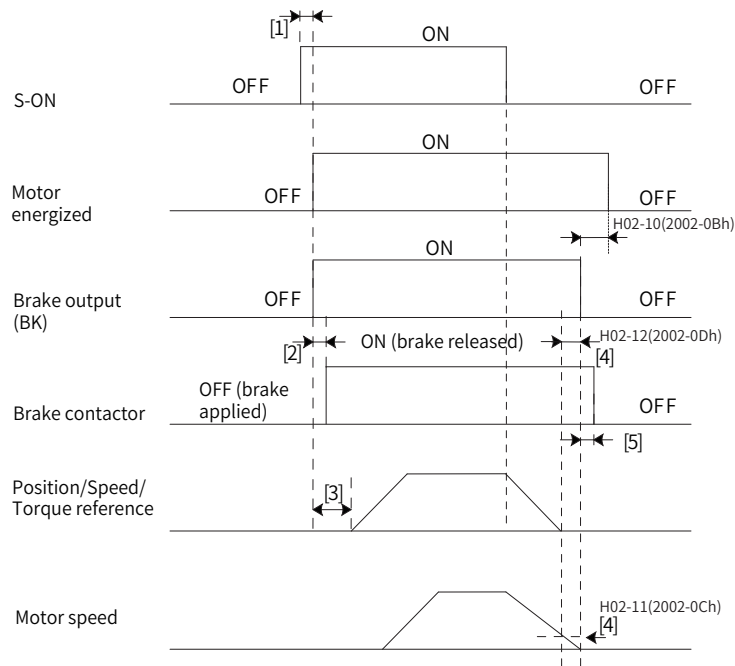

Figure 5-5 Brake time sequence for motor in the rotating state

- [1] For the brake delay time, see ["4 Keypad Display and Operations"](#) for details.
- [2] The time interval from the moment when brake output is on to the moment when the command is input must be longer than the value defined by 2009-0Ah/2000-34h.
- [3] When the S-ON signal is switched off during motor rotating, you can set the delay for brake output OFF by 2002-0Ch and 2002-0Dh.
- [4] The motor enters de-energized state only after the time defined by 2002-0Bh elapses upon brake output OFF.

☆ Related parameters

H02-11	Name	Motor speed threshold at brake output OFF in the rotating state			Setting Condition & Effective time	Any condition & Immediately	Data Structure	-	Data Type	Uint16
2002-0Ch	Access	RW	Mapping	-	Related Mode	All	Data Range	20-3000 (RPM)	Default	30
Defines the motor speed threshold when the brake output signal is off during motor rotating.										

H02-12	Name	Delay from S-ON OFF to brake output OFF in the rotating state			Setting Condition & Effective Time	Any condition & Immediately	Data Structure	-	Data Type	Uint16
2002-0Dh	Access	RW	Mapping	-	Related Mode	All	Data Range	1-1000 (ms)	Default	500
Defines the delay from the moment the when S-ON signal is off to the moment when brake output signal is off.										

■ Brake time sequence in quick stop

The states after quick stop can be divided into de-energized or position-lock depending on the stop mode. For the de-energized state (605Ah < 4), the brake output condition is the same as the brake time sequence under normal state (motor rotating).

■ Brake time sequence under fault state

The servo drive faults are classified into level 1 faults (No. 1) and level 2 (No. 2) faults. For details, see ["6 Troubleshooting"](#). The brake time sequences under fault state are divided into the following two

situations:

1) No. 1 faults:

When a No. 1 fault occurs and the brake is used, the stop mode is forcibly set to "Dynamic braking stop, keeping dynamic braking state", but the brake output condition is the same as the brake time sequence under normal state (motor rotating).

2) No. 2 faults:

When a No. 2 fault occurs and the brake is used, the stop mode is forcibly set to "Ramp to stop, keeping dynamic braking state", but the brake output condition is the same as the brake time sequence under normal state (motor rotating).

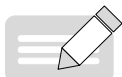

NOTE

◆ Recommended setpoints:

When the brake is used, the setpoint of 6085h (Stop deceleration) must meet the following requirement:

Deceleration time < 2002-0Dh

If the preceding requirement cannot be fulfilled, the deceleration command will be based on 2002-0Dh.

5.4.3 Regenerative Resistor Settings

When the motor torque direction is opposite to the direction of rotation, the energy is returned from the motor to the servo drive, causing bus voltage rise. Once the bus voltage rises to the braking threshold, the surplus energy must be consumed by a regenerative resistor. Otherwise, the servo drive will be damaged.

The regenerative resistor can be a built-in or an external one. However, a built-in regenerative resistor cannot be used together with an external one. The following table lists the specifications of the regenerative resistor.

Table 5-3 Specifications of the regenerative resistor

Servo Drive Model	Specifications of Built-in Regenerative Resistor			Minimum Permissible Resistance of External Regenerative Resistor (Ω) (H02-21)
	Resistance (Ω)	Power Pr (W)	Processable Power Pa (W)	
SV630NS1R6I	-	-	-	50
SV630NS2R8I	-	-	-	45
SV630NS5R5I	50	50	25	40
SV630NS7R6I	25	60	30	20
SV630NS012I				15
SV630NT3R5I	100	60	30	80
SV630NT5R4I	100	60	30	60
SV630NT8R4I	50	75	40	45
SV630NT012I				40
SV630NT017I	35	100	50	35
SV630NT021I				25
SV630NT026I				25

S1R6 and S2R8 models do not have the built-in regenerative resistor. For these models, you need to prepare an external regenerative resistor if required.

■ Without external load torque

The kinetic energy upon braking of a reciprocating motor motion is converted into electric energy and fed back to the bus capacitor. When the bus voltage rises above the braking voltage threshold, the regenerative resistor will consume the excessive feedback energy. The following figure shows the motor speed curve in a no-load operation from 3000 RPM to a standstill.

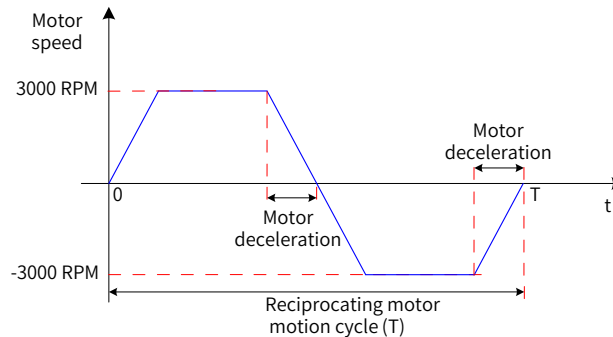

Figure 5-6 Motor speed curve without external load torque

■ Energy data calculation

SV630NS1R6I and SV630NS2R8I models do not carry a built-in regenerative resistor. The energy that can be charged by the capacitor is shown as follows. If the rotating energy of the servo motor and the load exceed the regenerative energy that can be processed, connect an external regenerative resistor.

Servo Drive Model	Processable Regenerative Energy	Remark
SV630NS1R6I	13.15	The input voltage of the main circuit power supply is 220 VAC.
SV630NS2R8I	26.29	

The following table lists the energy generated when a 220 V servo motor changes from no-load operation at the rated speed to a standstill.

Capacity (W)	Servo Motor Model MS1H* -***** -*****		Rotor Inertia J(10^{-4} kgm ²)	Braking Energy Generated When Changing From No-load Operation at Rated Speed to a Standstill E ₀ (J)	Maximum Braking Energy Absorbed by the Capacitor E _c (J)
750	MS1H1 (low inertia, small capacity)	MS1H1-75B30CB-*331Z	1.38	6.8	22.4
		MS1H1-75B30CB-*334Z	1.43	7.1	
1000	MS1H2 (low inertia, medium capacity)	MS1H2-10C30CB-*331Z	1.87	9.2	26.7
1500		MS1H2-15C30CB-*331Z		2.46	12.2
		MS1H2-15C30CB-*334Z			47.7
850	MS1H3 (medium inertia, medium capacity)	MS1H3-85B15CB-*331Z	13.3	65.8	22.4
1300		MS1H3-85B15CB-*334Z	14	69.2	
		MS1H3-13C15CB-*331Z	17.8	88.0	22.4
	MS1H3-13C15CB-*334Z	18.5	91.5		
750	MS1H4 (medium inertia, small capacity)	MS1H4-75B30CB-*331Z	2	9.9	22.4
		MS1H4-75B30CB-*334Z	2.012	9.9	

5 Commissioning and Operation

The following table lists the energy generated when a 380 V motor changes from no-load operation at the rated speed to a standstill.

Capacity (W)	Servo Motor Model MS1H*_*****_*****	Rotor Inertia J(10 ⁻⁴ kgm ²)	Braking Energy Generated When Changing From No- load Operation at Rated Speed to a Standstill E _o (J)	Maximum Braking Energy Absorbed by the Capacitor E _c (J)		
1000	MS1H2 (low inertia, medium capacity)	MS1H2-10C30CD-*331Z	1.87	9.2	34.3	
		MS1H2-10C30CD-*334Z				
1500		MS1H2-15C30CD-*331Z	2.46	12.2	34.3	
		MS1H2-15C30CD-*334Z				
2000		MS1H2-20C30CD-*331Z	3.06	15.1	50.4	
2500		MS1H2-25C30CD-*331Z	3.65	18.0	50.4	
3000		MS1H2-30C30CD-*331Z	7.72	38.2	50.4	
4000		MS1H2-40C30CD-*331Z	12.1	59.8	82.7	
5000		MS1H2-50C30CD-*331Z	15.4	76.2	82.7	
850		MS1H3 (medium inertia, medium capacity)	MS1H3-85B15CD-*331Z	13.3	65.8	28.2
			MS1H3-85B15CD-*334Z	14	69.2	34.3
1300			MS1H3-13C15CD-*331Z	17.8	88.0	34.3
			MS1H3-13C15CD-*334Z	18.5	91.5	34.3
1800			MS1H3-18C15CD-*331Z	25	123.6	50.4
	MS1H3-18C15CD-*334Z		25.7	127.1	50.4	
2900	MS1H3-29C15CD-*331Z		55	271.98	50.4	
	MS1H3-29C15CD-*334Z		55	271.98	50.4	
4400	MS1H3-44C15CD-*331Z		88.9	439.6	82.7	
	MS1H3-44C15CD-*334Z		88.9	439.6	82.7	
5500	MS1H3-55C15CD-*331Z		107	529.1	100.8	
	MS1H3-55C15CD-*334Z		107	529.1	100.8	
7500	MS1H3-75C15CD-*331Z		141	697.3	100.8	
	MS1H3-75C15CD-*334Z		141	697.3	100.8	

If the time needed by the whole braking process is known (T), you can determine whether an external regenerative resistor is required and calculate the power of the resistor needed by using the following flowchart and formula.

■ Regenerative resistor selection

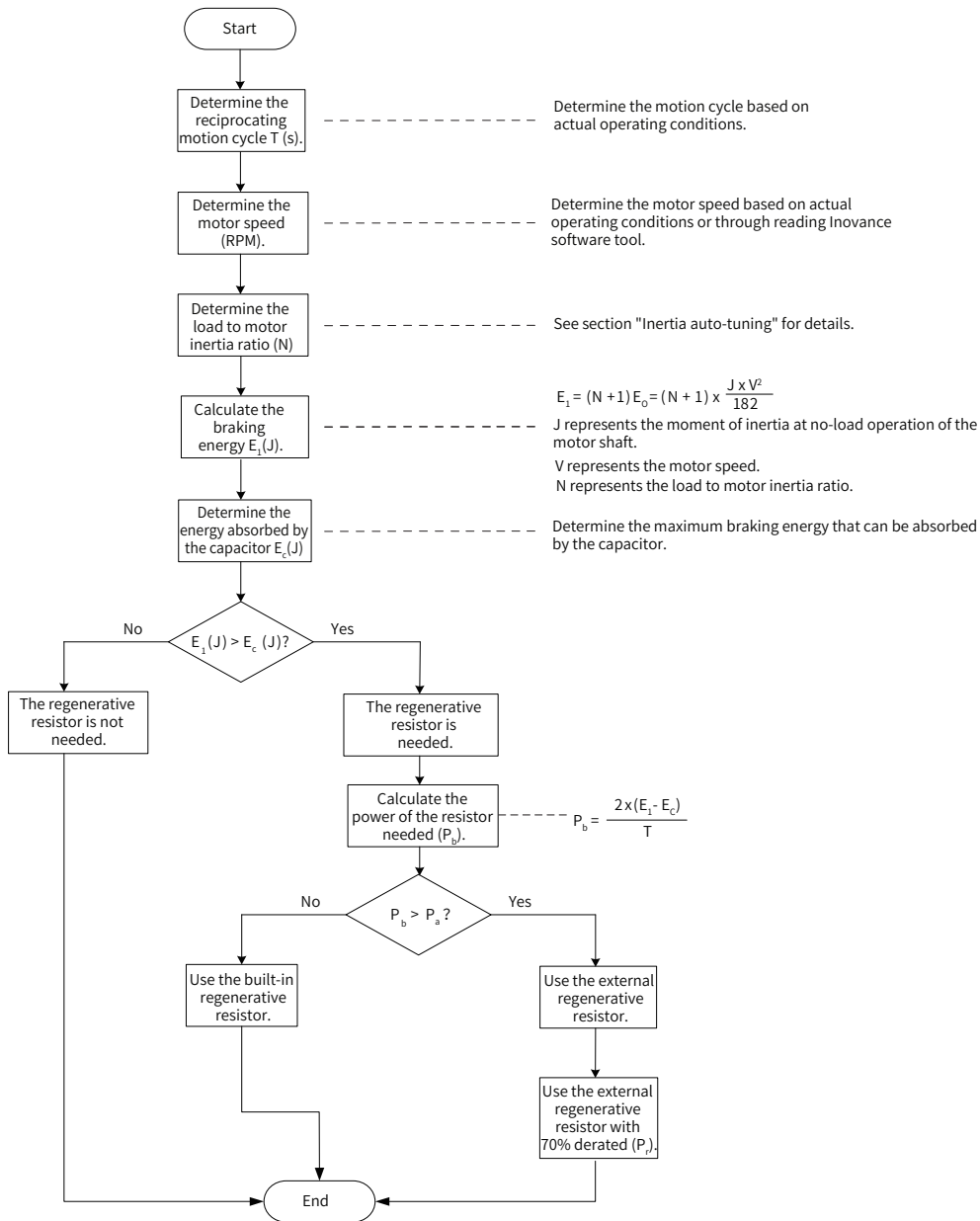

Figure 5-7 Flowchart for selecting the regenerative resistor



NOTE

- ◆ Assume that the load inertia is motor inertia multiplied by N, the braking energy is $(N + 1) \times E_o$ when the motor decelerates from 3000 RPM to 0 RPM, the energy consumed by the regenerative resistor will be $(N+1) \times E_o - E_c$ (unit: J) after deducting the energy (E_c) absorbed by the capacitor. Assume the reciprocating motion cycle is T, the regenerative resistor power needed will be $2 \times [(N + 1) \times E_o - E_c] / T$.
- ◆ Determine whether to use the regenerative resistor according to the preceding flowchart and set H02-25 (Regenerative resistor type) accordingly.
- ◆ The resistor with an aluminum housing is recommended.

☆ Related parameter

Parameter No.	Name	Value Range	Function	Setting Condition	Effective Time	Default	
2002h	1A	Regenerative resistor type	0- Reserved 1: External, natural ventilation 2: External, forced air cooling 3: No regenerative resistor needed	Defines the mode of absorbing and releasing the braking energy.	At stop	Immediately	3

Take the H1 series 750 W model as an example. Assume the reciprocating motion cycle (T) is 2s, the maximum speed is 3000 RPM, and the load inertia is four times the motor inertia, the regenerative resistor power needed will be as follows:

$$P_b = \frac{2 \times [(N+1) \times E_o - E_c]}{T} = \frac{2 \times [(4+1) \times 6.4 - 26]}{2} = 6 \text{ W}$$

The calculation result is smaller than the processable capacity ($P_a = 25 \text{ W}$) of the built-in regenerative resistor, so a built-in regenerative resistor can meet the requirement.

If the inertia ratio in preceding example is changed to 10 times the motor inertia, and other conditions remain the same, the regenerative resistor power needed will be as follows:

$$P_b = \frac{2 \times [(N+1) \times E_o - E_c]}{T} = \frac{2 \times [(10+1) \times 6.4 - 26]}{2} = 44.4 \text{ W}$$

The calculation result is larger than the processable capacity ($P_a = 25 \text{ W}$) of the built-in regenerative resistor, so an external regenerative resistor is required. The recommended power of the external regenerative resistor is $P_b / (1 - 70\%) = 148 \text{ W}$.

1) Connection and setting of the regenerative resistor

■ When using an external regenerative resistor

Use the external regenerative resistor with 70% derated, that is, $P_r = P_b / (1 - 70\%)$, and ensure the resistance of the regenerative resistor is larger than the minimum permissible value. Remove the jumper between terminals P and D, and connect the external regenerative resistor between terminals P ⊕ and C.

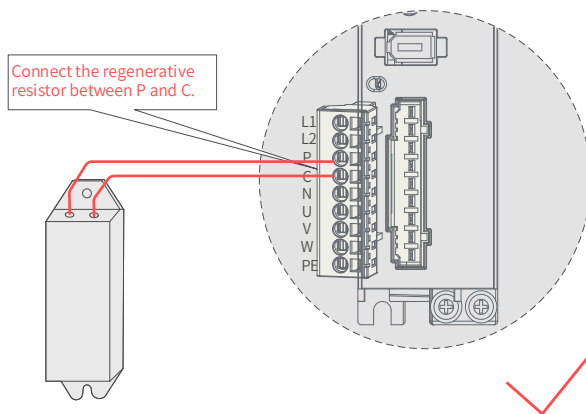

Figure 5-8 Connection of an external regenerative resistor

See "[Table 3-6 Recommended main circuit cables](#)" for cable information on terminals P ⊕ and C.

Set 2002-1Ah to 1 or 2 based on the cooling mode of the regenerative resistor and set the following parameters properly.

☆ Related parameters

Parameter No.		Name	Value Range	Unit	Function	Setting Condition	Effective Time	Default
2002h	16h	Minimum permissible resistance of regenerative resistor	Non-settable and model dependent	-	Displays the minimum permissible resistance of the external regenerative resistor.	At display	-	Model dependent
2002h	1Bh	Power of external regenerative resistor	1-65535	W	Defines the power of the external regenerative resistor used. Note: The power of the external regenerative resistor used cannot be smaller than the calculated braking power.	At stop	Immediately	Model dependent
2002h	1Ch	Resistance of external regenerative resistor	1-1000	Ω	Defines the resistance of the external regenerative resistor used. Note: The resistance of the external regenerative resistor (2002-1Ch) used cannot be smaller than the minimum permissible resistance of regenerative resistor (2002-16h). Otherwise, Er.922.0 will occur.	At stop	Immediately	Model dependent



	<ul style="list-style-type: none"> ◆ Set the resistance (2002-1Ch) and power (2002-1Bh) of the external regenerative resistor properly. Improper settings will impact the performance. ◆ When an external regenerative resistor is used, ensure the resistance of the external regenerative resistor is larger than the minimum permissible value. ◆ When the regenerative resistor is used within the operating temperature range, at the processable power (average value), and under the rated capacity, the temperature of the resistor will rise to above 120° C during continuous braking. To ensure safety, cool the resistor down by forced air cooling or use a resistor with a thermal switch. For load characteristics of the regenerative resistor, contact the manufacturer.
--	--

Set the heat dissipation coefficient based on the heat dissipation condition of the external regenerative resistor.

☆ Related parameter:

Parameter No.	Name	Value Range	Unit	Function	Setting Condition	Effective Time	Default
2002h 19h	Resistor heat dissipation coefficient	10-100	%	Defines the heat dissipation coefficient when an external regenerative resistor is used. The value cannot be higher than 30% when natural ventilation is used. The value cannot be higher than 50% when forced air cooling is used.	At stop	Immediately	30



- ◆ The larger the heat dissipation coefficient is, the higher the braking efficiency is.
- ◆ When $P_b < P_a$ and $E_1 > E_c$, use the built-in regenerative resistor. In this case, set H02-25 to 0.
- ◆ When $E_1 < E_c$, no regenerative resistor is required. This is because the bus capacitor can absorb the braking energy. In this case, set 2002-1Ah to 3.

2) With external load torque and motor staying in the generating state

When the motor torque direction is the same as the axis rotating direction, the motor outputs mechanical energy. In some special applications where the motor torque output is opposite to the rotating direction, the motor is in power generating status and feeds the electric energy back to the servo drive.

When the load is in continuous power-generating status, it is recommended to adopt the common DC bus topology.

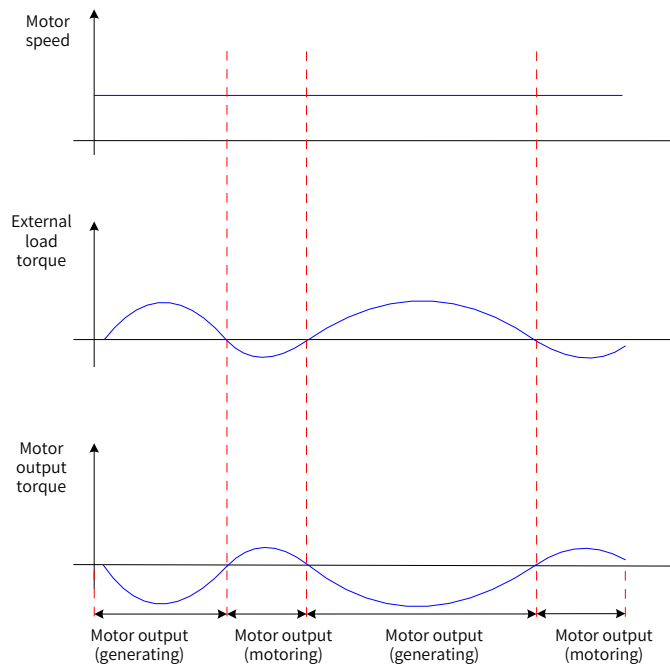

Figure 5-9 Example of the curve with external load torque

Take the H1 series 750 W model (rated torque 2.39 N·m) as an example. When the external load torque is 60% of the rated torque and the motor speed is 1500 RPM, the power fed back to the servo drive is:
 $(60\% \times 2.39) \times (1500 \times 2\pi/60) = 225 \text{ W}$. As the regenerative resistor is derated by 70%, the power of the external regenerative resistor is: $225/(1 - 70\%) = 750 \text{ W}$, with 50 Ω resistance.

5.5 Servo Running

- 1) Switch on the S-ON signal.

When the servo drive is ready to run, the keypad displays "rn". However, if there is no command input at this moment, the servo motor will stay in the locked state, without rotating.

- 2) After a command is input, the servo motor starts rotating.

Table 5-4 Instructions for operating the servo drive

Record	No.	Description
<input type="checkbox"/>	1	At initial operation, set a proper reference to make the motor run at low speed and check whether the motor rotates properly.
<input type="checkbox"/>	2	Observe whether the motor rotates in the correct direction. If the motor rotates in an opposite direction, check the input reference and reference direction.
<input type="checkbox"/>	3	If the motor rotates correctly, observe the motor speed actual value in 200B-01h and the average load rate in 200B-0Dh through the keypad or Inovance software tool.
<input type="checkbox"/>	4	After checking the preceding operating conditions, set related parameters properly to adapt the motor to actual operating conditions.
<input type="checkbox"/>	5	Perform commissioning on the servo drive according to the instructions in Chapter 6.

- 3) Power-on timing diagram

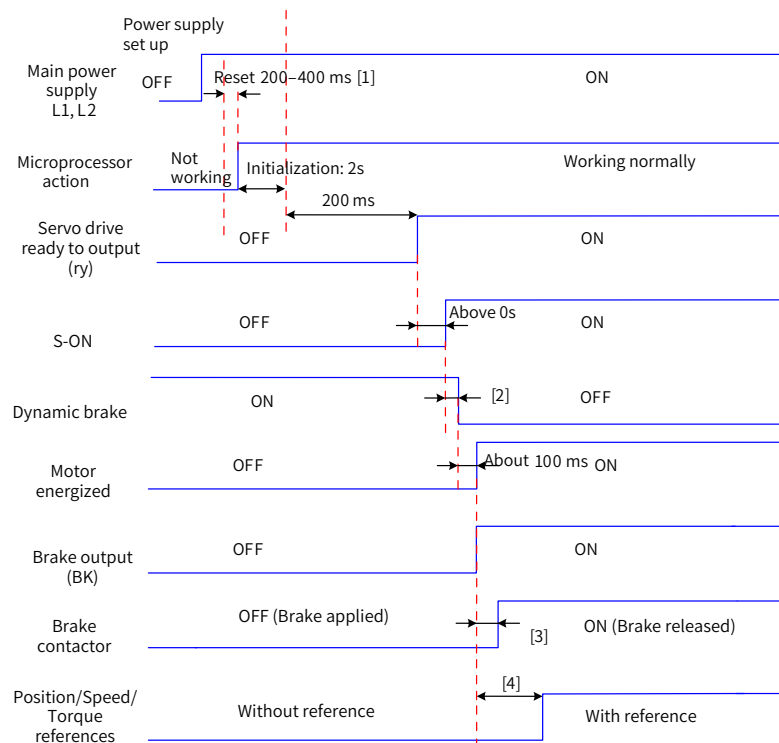

Figure 5-10 Power-on timing diagram

- [1] The reset time is determined by the setup time of the +5V power supply of the microprocessor.
- [2] The dynamic brake is included in the standard configuration.
- [3] For brake contactor delay, see ["4 Keypad Display and Operations"](#) for details.
- [4] When the brake function is not used, the command delay time is invalid.

4) Timing diagram for stop upon warning or fault

■ Fault 1: Coast to stop, keeping de-energized status

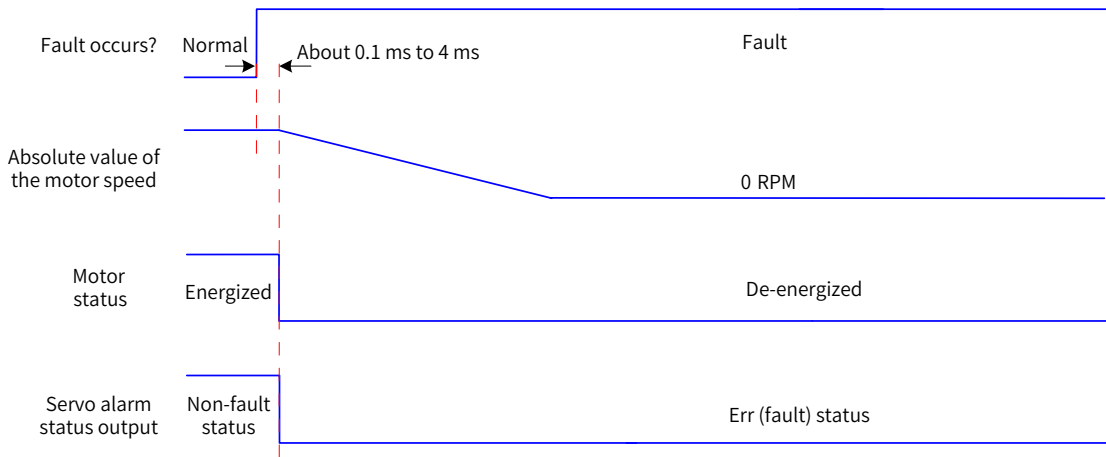

Figure 5-11 Timing diagram of "coast to stop, keeping de-energized status" at No. 1 fault

■ Fault 1 (without brake): Dynamic braking stop, keeping de-energized status

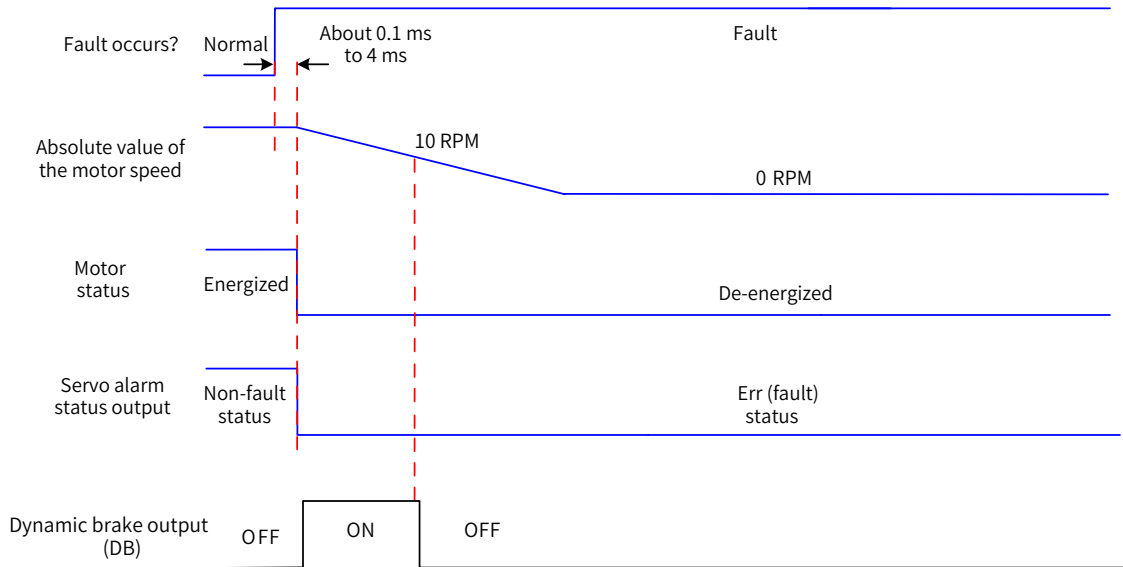

Figure 5-12 Timing diagram of "Dynamic braking stop, keeping de-energized status" at No. 1 fault (without brake)

■ Fault 1 (with brake): Dynamic braking stop, keeping dynamic braking status

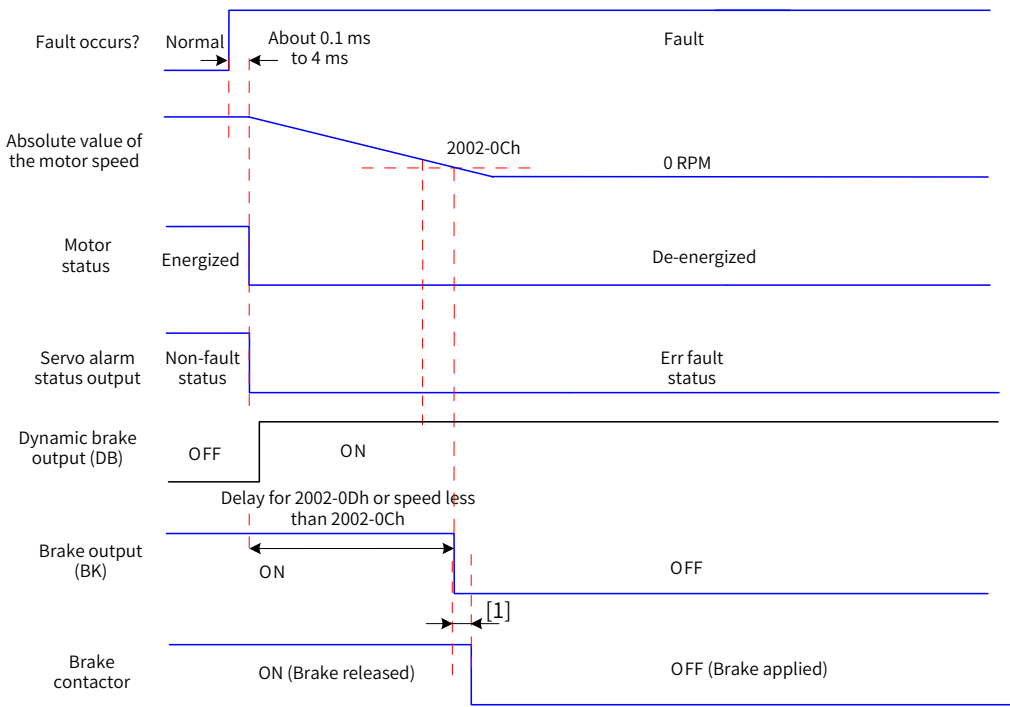

Figure 5-13 Timing diagram of "Dynamic braking stop, keeping dynamic braking status" at No. 1 fault (with brake)

[1] For brake contactor delay, see "4 Keypad Display and Operations" for details.

■ Fault 1 (without brake): Dynamic braking stop, keeping dynamic braking status

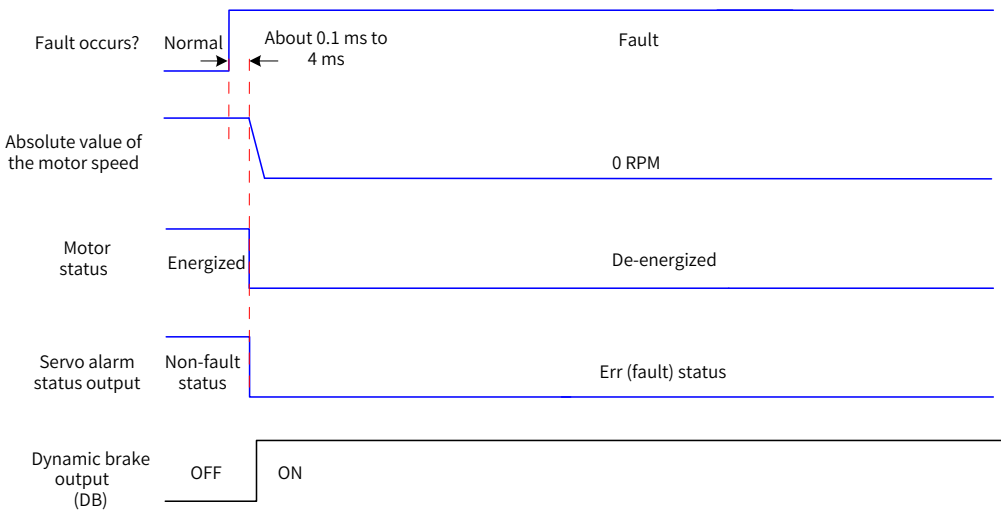

Figure 5-14 Timing diagram of "Dynamic braking stop, keeping dynamic braking state" at No. 1 fault (without brake)

■ Fault 2 (without brake)

Coast to stop, keeping de-energized status, same as "Coast to stop upon No. 1 fault"

Dynamic braking stop, keeping dynamic braking status^[1]

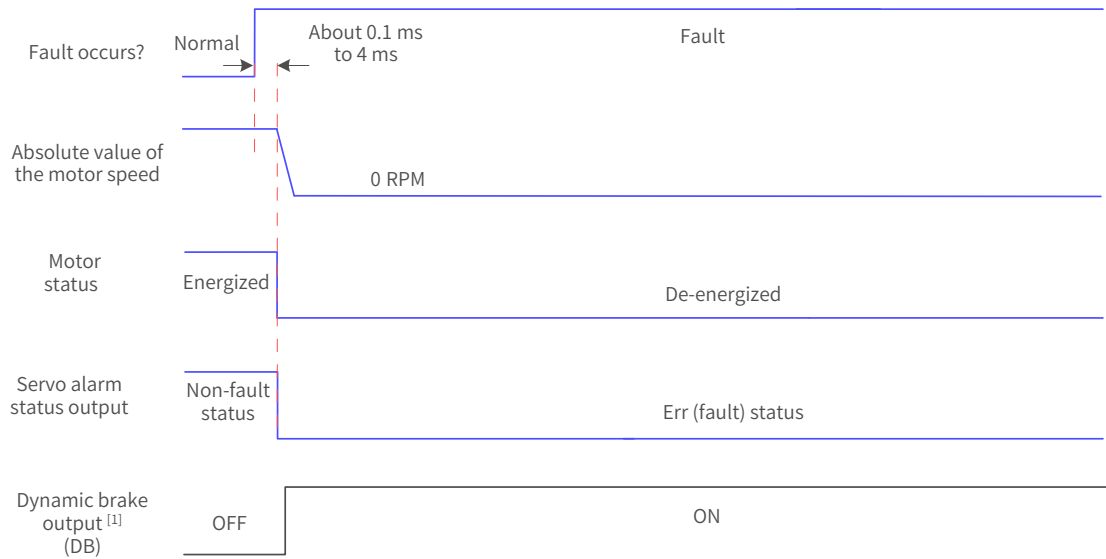

Figure 5-15 Timing diagram of "Coast to stop, keeping de-energized state" at No. 2 fault (without brake)

[1] After the dynamic brake is enabled

- Fault 2 (without brake): Ramp to stop or stop at emergency torque, keeping de-energized/dynamic braking status^[1]

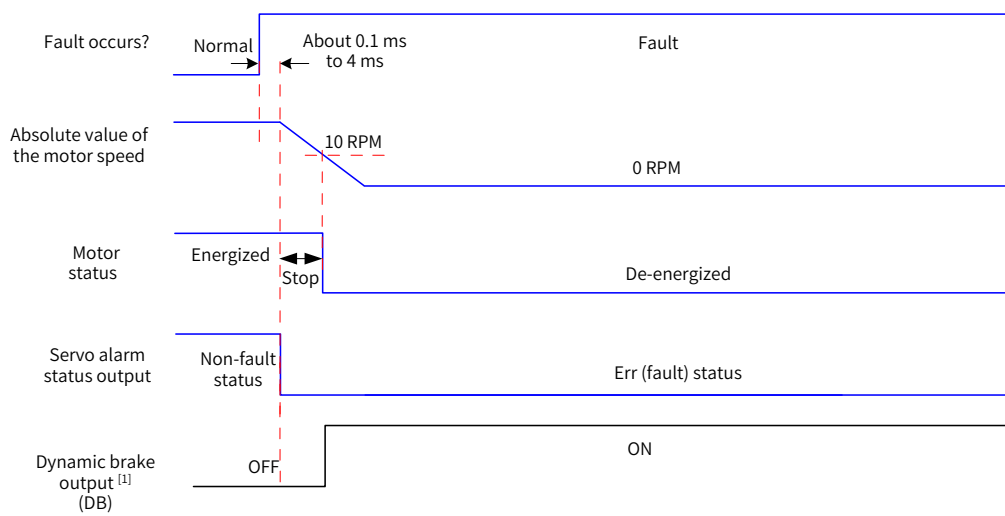

Figure 5-16 Timing diagram of "Ramp to stop or stop at emergency stop torque, keeping de-energized state" at No. 2 fault (without brake)

[1] After the dynamic brake is enabled

■ Fault 2 (with brake): Ramp to stop, keeping dynamic braking status

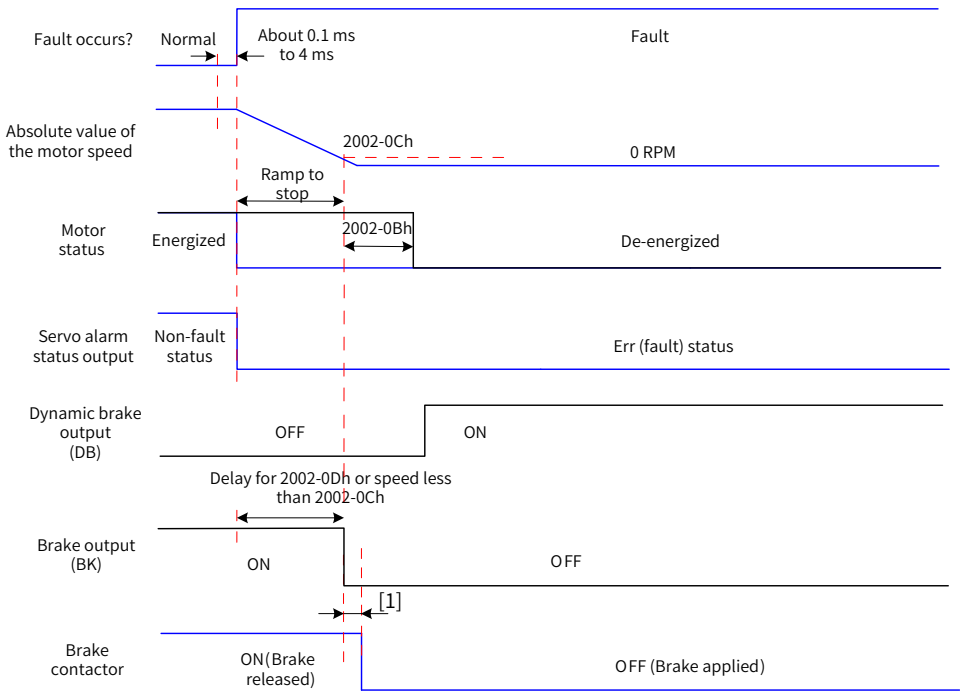

Figure 5-17 Timing diagram of "Ramp to stop, keeping dynamic braking state" at No. 2 fault (with brake)

[1] For brake contactor delay, see "4 Keypad Display and Operations" for details.

When a No. 3 warning occurs on the servo drive, such as Er.950.0 (Forward overtravel warning) and Er.952.0 (Reverse overtravel warning), the servo drive stops as shown in the following figure.

■ Overtravel warning

Stopping at zero speed as defined by 6085h if the brake function is enabled, keeping position lock status
 Stopping at zero speed if the brake function is disabled, keeping position lock status

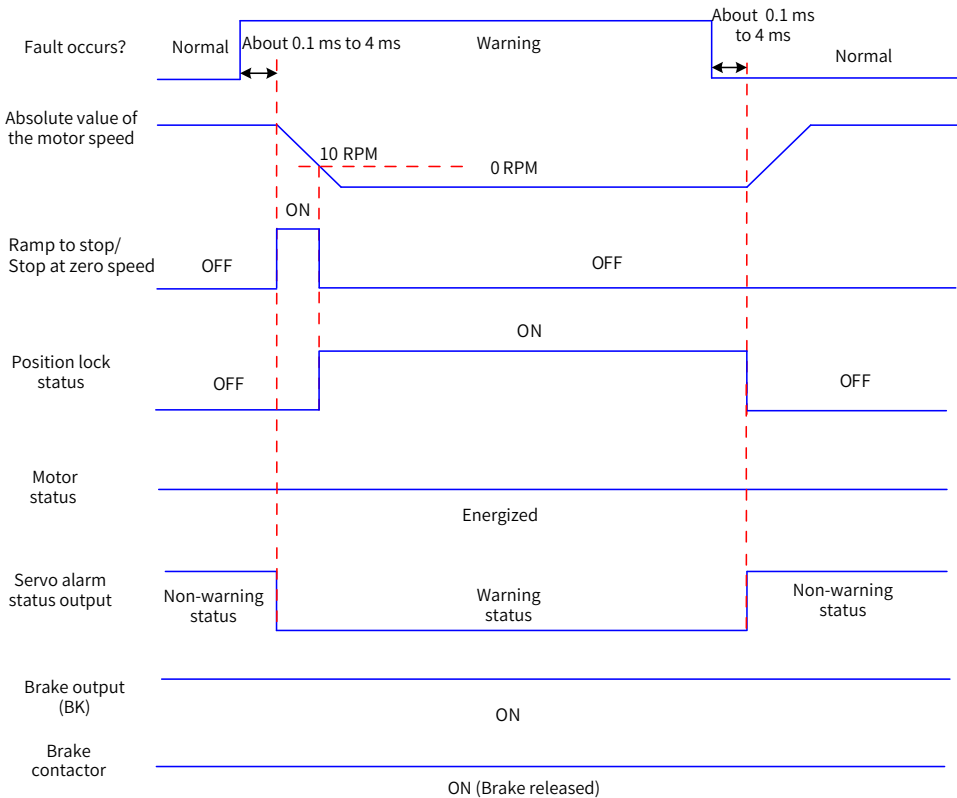

Figure 5-18 Timing diagram for warnings that cause stop

Except Er.950 and Er.952, the other warnings do not affect the operating status of the servo drive. The timing diagram upon occurrence of these warnings is as follows:

■ Warnings that do not cause stop

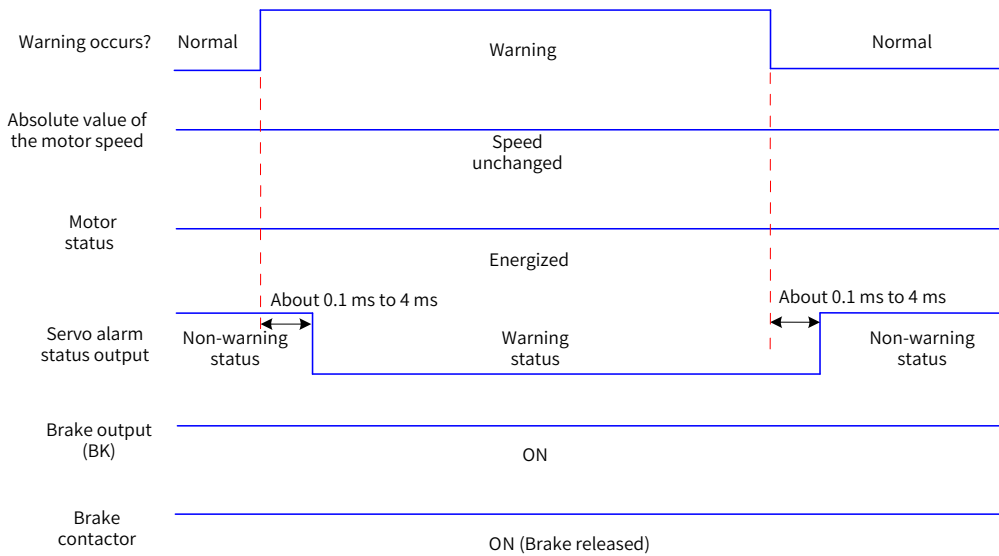

Figure 5-19 Timing diagram at warnings that do not cause stop

■ Fault reset

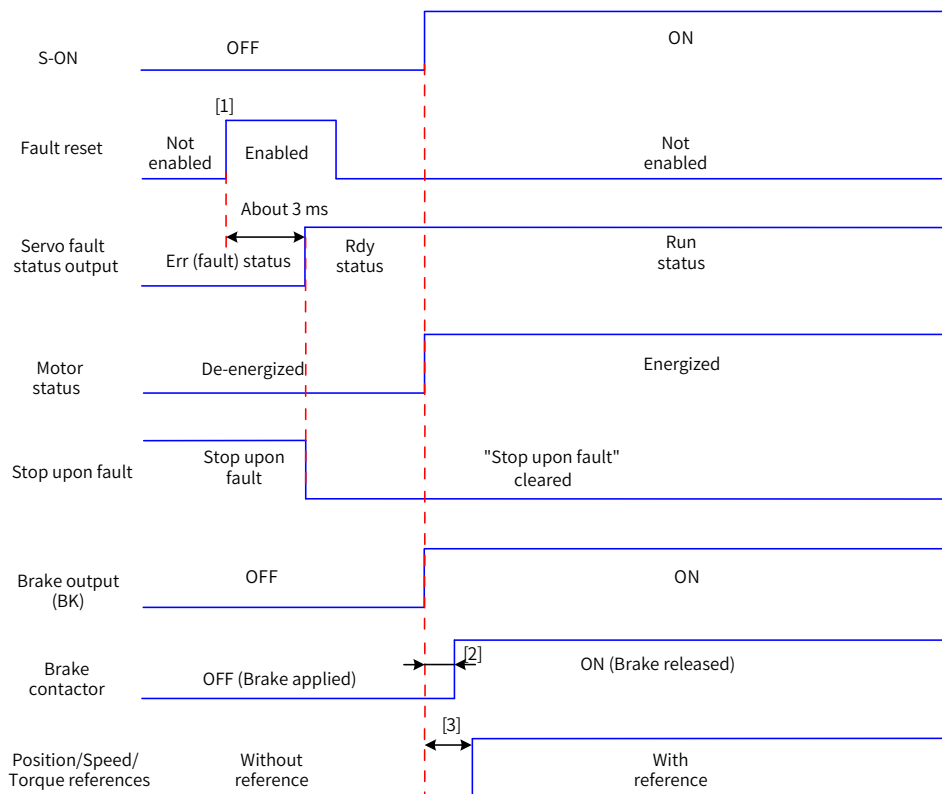

Figure 5-20 Timing diagram of fault reset

- [1] The fault reset signal is edge-triggered.
- [2] For brake contactor delay, see ["4 Keypad Display and Operations"](#) for details.
- [3] The command delay is invalid when the brake function is not enabled.

5.6 Servo Stop

The stop modes can be coast to stop, stop at zero speed, ramp to stop, stop at emergency torque, and dynamic braking stop. The stop status can be de-energized status, position lock status, and dynamic braking status. See the following table for details.

Table 5-5 Comparison of stop modes

Stop Mode	Description	Feature
Coast to stop	The servo motor is de-energized and decelerates to 0 RPM gradually. The deceleration time is affected by mechanical inertia and friction.	This mode features smooth deceleration and small mechanical impact, but the deceleration process is slow.
Stop at zero speed	The servo motor decelerates immediately to 0 RPM and stops.	This mode features quick deceleration, but the mechanical impact is large.
Ramp to stop	The servo motor decelerates to 0 RPM smoothly upon receiving position/speed/torque references.	This mode features a smooth and controllable deceleration process with small mechanical impact.
Stop at emergency torque	The servo drive outputs a reverse braking torque to stop the motor.	This mode features quick deceleration, but the mechanical impact is large.
Dynamic braking stop	The servo motor is in the dynamic braking status.	This mode features quick deceleration, but the mechanical impact is large.

Table 5-6 Comparison of stop status

Stop Status	Description
De-energized	The motor is de-energized after it stops rotating, and the motor shaft can be rotated freely.
Position lock	The motor shaft is locked and cannot be rotated freely after the motor stops rotating.
Dynamic braking	The motor is de-energized after it stops rotating, and the motor shaft cannot be rotated freely.

The servo drive stops under the following situations:

- S-ON OFF

Switch off the S-ON signal through communication, and the servo drive stops according to the stop mode at S-ON OFF.

☆ Related parameters:

H02-05	Name	Stop mode at S-ON OFF			Setting Condition & Effective Time	At stop & Immediately	Data Structure	-	Data Type	Int16
2002-06h	Access	RW	Mapping	No	Related Mode	All	Data Range	-3 to +1	Data Type	0

Defines the deceleration mode of the servo motor for stopping rotating and the servo motor state after stops due to S-ON OFF.

Setpoint	Stop mode
-3	Stop at zero speed, keeping dynamic braking status
-2	Ramp to stop as defined by 6084/609A, keeping dynamic braking status
-1	Dynamic braking stop, keeping dynamic braking status
0	Coast to stop, keeping de-energized status
1	Ramp to stop as defined by 6084/609A, keeping de-energized status

Set a proper stop mode according to the mechanical condition and operating requirements.

After the brake output function is enabled, the stop mode at S-ON off is forcibly set to "Ramp to stop as defined by 6085h, keeping dynamic braking status".

605Ch	Name	Disable operation option code			Setting Condition & Effective Time	At stop & At stop	Data Structure	-	Data Type	Int16
	Access	RW	Mapping	NO	Related Mode	ALL	Data Range	-4 to +1	Default	0

Defines the deceleration mode of the servo motor for stopping rotating and the servo motor state after stops due to S-ON OFF.

Value	Stop Mode
-4	Ramp to stop as defined by 6085h, keeping dynamic braking status
-3	Stop at zero speed, keeping dynamic braking status
-2	Ramp to stop as defined by 6084/609A, keeping dynamic braking status
-1	Dynamic braking stop, keeping dynamic braking status
0	Coast to stop, keeping de-energized status
1	Ramp to stop as defined by 6084/609A, keeping de-energized status

Set a proper stop mode based on the mechanical condition and operating requirements.

After the brake output function is enabled, the stop mode at S-ON off is forcibly set to "Ramp to stop as defined by 6085h, keeping dynamic braking state".



NOTE

◆ The stop mode can be set in H02-05 or 605C. If the value of H02-05 or 605C changes, the value of 605C or H02-05 also changes.

■ Stop at fault

The stop mode varies with the fault type. See "[6 Troubleshooting](#)" for details.

☆ Related parameters:

H02-08	Name	Stop mode at No. 1 fault			Setting Condition & Effective Time	At stop & Immediately	Data Structure	-	Data Type	Uint16
2002-09h	Access	RW	Mapping	RPDO	Related Mode	All	Data Range	0-2	Default	2

Defines the deceleration mode of the servo motor for stopping rotating and the servo motor state after stops due to a No. 1 fault.

Value	Stop mode
0	Coast to stop, keeping de-energized status
1	Dynamic braking stop, keeping de-energized status
2	Dynamic braking stop, keeping dynamic braking status

After the brake output function is enabled, the stop mode at No. 1 fault is forcibly set to "Dynamic braking stop, keeping dynamic braking state".

H02-06	Name	Stop mode at No. 2 fault			Setting Condition & Effective Time	At stop & Immediately	Data Structure	-	Data Type	Int16
2002-07h	Access	RW	Mapping	-	Related Mode	ALL	Data Range	-5 to +3	Default	2

Defines the deceleration mode of the servo motor for stopping rotating and the servo motor state after stops due to a No. 2 fault.

Value	Stop Mode
-5	Stop at zero speed, keeping dynamic braking status
-4	Stop at emergency torque, keeping dynamic braking status
-3	Ramp to stop as defined by 6085, keeping dynamic braking status
-2	Ramp to stop as defined by 6084/609A, keeping dynamic braking status
-1	Dynamic braking stop, keeping dynamic braking status
0	Coast to stop, keeping de-energized status
1	Ramp to stop as defined by 6084/609A, keeping de-energized status
2	Ramp to stop as defined by 6085, keeping de-energized status
3	Stop at emergency torque, keeping e-energized status

After the brake output function is enabled, the stop mode at No. 2 fault is forcibly set to "Ramp to stop as defined by 6085h, keeping dynamic braking status".

605Eh	Name	Fault reaction option code			Setting Condition & Effective Time	At stop & At stop	Data Structure	-	Data Type	Int16
	Access	RW	Mapping	NO	Related Mode	ALL	Data Range	-5 to +3	Default	2

Defines the deceleration mode of the servo motor for stopping rotating and the servo motor state after stops at a No. 2 fault.

Value	Stop Mode
-5	Stop at zero speed, keeping dynamic braking status
-4	Stop at emergency torque, keeping dynamic braking status
-3	Ramp to stop as defined by 6085, keeping dynamic braking status
-2	Ramp to stop as defined by 6084/609A, keeping dynamic braking status
-1	Dynamic braking stop, keeping dynamic braking status
0	Coast to stop, keeping de-energized status
1	Ramp to stop as defined by 6084/609A, keeping de-energized status
2	Ramp to stop as defined by 6085, keeping de-energized status
3	Stop at emergency torque, keeping e-energized status

After the brake output function is enabled, the stop mode at No. 2 fault is forcibly set to "Ramp to stop as defined by 6085h, keeping dynamic braking status".



◆ The "Stop mode at No. 2 fault " can be set in H02-06 or 605E. If the value of H02-06 or 605E changes, the value of the other one changes accordingly.

■ Stop at overtravel

Definition of terms:

"Overtravel": The distance of the mechanical movement exceeds the designed range of safe movement.

"Stop at overtravel": When the motion part moves beyond the range of safe movement, the limit switch changes the signal level on the digital input, and the servo drive forces the motor to stop.

☆ Related parameters:

H02-07	Name	Stop mode at overtravel		Setting Condition & Effective Time	At stop & Immediately	Data Structure	-	Data Type	Uint16	
2002-08h	Access	RW	Mapping	-	Related Mode	All	Data Range	0-7	Default	1

Defines the deceleration mode of the servo motor for stopping rotating and the servo motor state after stops due to overtravel.

Value	Stop mode
0	Coast to stop, keeping de-energized status
1	Stop at zero speed, keeping position lock status
2	Stop at zero speed, keeping de-energized status
3	Ramp to stop as defined by 6085h, keeping de-energized status
4	Ramp to stop as defined by 6085h, keeping position lock status
5	Dynamic braking stop, keeping de-energized status
6	Dynamic braking stop, keeping dynamic braking status
7	Not responding to overtravel

When the servo motor drives a vertical axis, for the sake of safety, set 2002-08h to 1 to make the motor shaft stay in the position lock status after overtravel occurs.

After the brake output function is enabled, the stop mode at overtravel is forcibly set to "Stop as defined by 6085h, keeping position lock status".

If the servo motor enters the overtravel status when driving a vertical axis, the workpiece may fall. To prevent such risk, set 2002-08h to 1. When the workpiece moves linearly, install limit switches to prevent mechanical damage. In the overtravel status, input a reverse run command to make the motor (workpiece) run in the reverse direction.

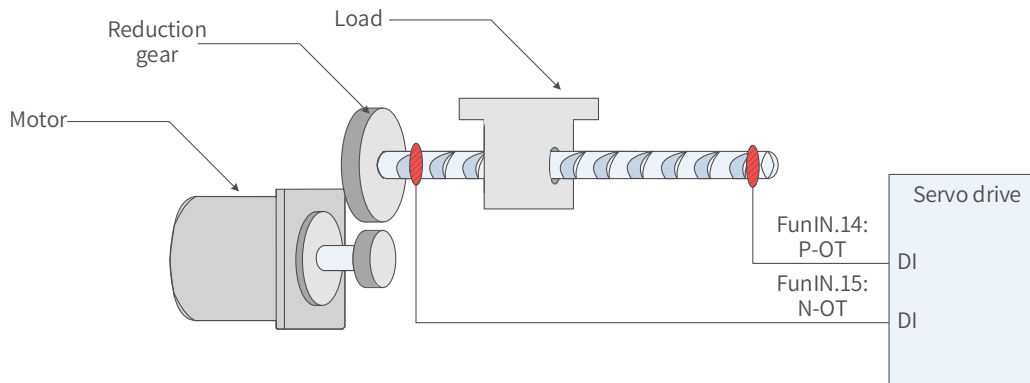

Figure 5-21 Installation of limit switches

To use the limit switch, allocate FunIN.14 (P-OT, positive limit switch) and FunIN.15 (N-OT, negative limit switch) to two DIs of the servo drive and set the active logic of these DIs. This is to enable the servo drive to receive the level signals inputted from the limit switches. The servo drive enables or cancels the stop-at-overtravel status based on the DI level status.

☆ Related DI functions

Function No.	Name	Function	Description
FunIN.14	P-OT	Positive limit switch	Overtravel prevention applies when the mechanical movement is beyond the movable range. Inactive: Forward drive permitted Active: Forward drive inhibited
FunIN.15	N-OT	Negative limit switch	Overtravel prevention applies when the mechanical movement is beyond the movable range. Inactive: Reverse drive permitted Active: Reverse drive inhibited

■ Emergency stop

The emergency stop can be implemented through the following two methods:

- 1) FunIN.34: EmergencyStop
- 2) 200D-06h (Emergency stop)

☆ Related DI function

Function No.	Name	Function	Description
FunIN.34	EmergencyStop	Braking	Inactive: The servo drive keeps the present operating status. Active: The servo drive stops according to the stop mode defined by 605Ah.

☆ Related parameter

H0D-05	Name	Emergency stop			Setting Condition & Effective Time	During running & Immediately	Data Structure	-	Data Type	Uint16
200D-06h	Access	RW	Mapping	-	Related Mode	-	Data Range	0-1	Default	0

Defines whether to enable emergency stop:

Value	Description
0	No operation
1	Emergency stop enabled

When H0D-05 is enabled, the servo drive stops in the stop mode defined by 605Ch regardless of the operating state.

■ Quick stop

Quick stop applies when bit2 (Quick stop) in the control word 6040h is set to 0 (Valid). The quick stop mode is defined by 605Ah.

605Ah	Name	Quick stop option code			Setting Condition & Effective Time	Any condition & At stop	Data Structure	VAR	Data Type	Int16
	Access	RW	Mapping	No	Related Mode	All	Data Range	0-7	Default	2

Defines the deceleration mode of the servo motor for stopping rotating and the servo motor state after quick stop.

Value	Stop mode
0	Coast to stop, keeping de-energized status
1	Ramp to stop as defined by 6084h/609Ah (HM), keeping de-energized status
2	Ramp to stop as defined by 6085h, keeping de-energized status
3	Stop at emergency torque, keeping de-energized status
4	N/A
5	Ramp to stop as defined by 6084h/609Ah (HM), keeping position lock status
6	Ramp to stop as defined by 6085h, keeping position lock status
7	Stop at emergency-stop torque, keeping position lock status

When the brake function is enabled and the setpoint of 605Ah is less than 4, the stop mode is forced to "Ramp to stop as defined by 6085h, keeping de-energized state".

■ Halt

The halt function applies when bit8 in the control word 6040h is set to 1 (Valid). The halt mode is defined by 605Dh.

605Dh	Name	Stop option code			Setting Condition & Effective Time	Any condition & At stop	Data Structure	VAR	Data Type	Int16
	Access	RW	Mapping	No	Related Mode	All	Data Range	1-3	Default	1



Defines the deceleration mode of the servo motor for stopping rotating and the servo motor state after halt.

PP/PV/HM mode:

Setpoint	Stop mode
1	Ramp to stop as defined by 6084h/609Ah (HM), keeping position lock status
2	Ramp to stop as defined by 6085h, keeping position lock status
3	Stop at emergency-stop torque, keeping position lock status

PT mode:

Setpoint	Stop mode
1/2/3	Ramp to stop as defined by 6087h, keeping position lock statestatus

	
	Do not set the acceleration/deceleration time to an excessively small value. An excessively small value will lead to an overlong stop distance, causing the risk of collision.

■ Maximum time of ramp-to-stop

When the stop mode is set to "Ramp to stop as defined by 6084h/609Ah (HM)" or "Ramp to stop as defined by 6085h", set the maximum time for ramp-to-stop through H0A-72 to prevent an overlong stop distance caused by an excessively small deceleration setpoint. When 6084h/609Ah (HM) or 6085h is set to an excessively small value, the stop deceleration is restricted by the setpoint of H0A-72.

H0A-72	Name	Maximum time for ramp-to-stop			Setting Condition & Effective Time	At stop & Immediately	Data Structure	-	Data Type	Uint16
200A-49h	Access	RW	Mapping	-	Related Mode	ALL	Data Range	0-65535 (ms)	Default	10000

Defines the maximum time taken by the motor in decelerating from 6000 RPM to 0 RPM when the stop mode is set to "Ramp to stop as defined by 6084h/609Ah (HM)" or "Ramp to stop as defined by 6085h".

5.7 Conversion Factor Setting

Gear ratio refers to the motor displacement (in encoder unit) corresponding to the load shaft displacement of one reference unit.

The gear ratio is comprised of the numerator 6091-01h and denominator 6091-02h. It determines the proportional relation between the load shaft displacement (in reference unit) and the motor displacement (in encoder unit), as shown below.

$$\text{Motor displacement} = \text{Load shaft displacement} \times \text{Gear ratio}$$

The motor is connected to the load through the reducer and other mechanical transmission mechanisms. Therefore, the gear ratio is related to the mechanical reduction ratio, mechanical dimensions and motor encoder resolution. The calculation formula is as follows.

$$\text{Gear ratio} = \frac{\text{Motor encoder resolution}}{\text{Load shaft resolution}}$$

Index	Name	Gear ratio			Setting Condition & Effective Time	-	Data Structure	ARR	Data Type	Uint32
6091h	Access	-	Mapping	Yes	Related Mode	All	Data Range	OD data range	Default	OD default value

Defines the proportional relation between the load shaft displacement designated by the user and the motor shaft displacement.

The relation between motor position feedback (in encoder unit) and load shaft position feedback (in reference unit) is as follows.

$$\text{Motor position feedback} = \text{Load shaft position feedback} \times \text{Gear ratio}$$

The relation between the motor speed (RPM) and the load shaft speed (in reference unit/s) is as follows.

$$\text{Motor speed (RPM)} = \frac{\text{Load shaft speed} \times \text{Gear ratio } 6091h}{\text{Encoder resolution}} \times 60$$

The relation between motor acceleration (RPM/ms) and the load shaft speed (in reference unit/s²) is as follows.

$$\text{Motor acceleration} = \frac{\text{Load shaft acceleration} \times \text{Gear ratio } 6091h}{\text{Encoder resolution}} \times \frac{1000}{60}$$

5 Commissioning and Operation

Sub-index 0h	Name	Number of gear ratio sub-indexes			Setting Condition & Effective Time	-	Data Structure	-	Data Type	Uint8
	Access	RO	Mapping	No	Related Mode	-	Data Range	-	Default	2

Sub-index 1h	Name	Motor revolutions			Setting Condition & Effective Time	During running & Immediately	Data Structure	-	Data Type	Uint32
	Access	RW	Mapping	RPDO	Related Mode	-	Data Range	1 to (2 ³² -1)	Default	Depending on encoder resolution

Sub-index 2h	Name	Shaft revolutions			Setting Condition & Effective Time	During running & Immediately	Data Structure	-	Data Type	Uint32
	Access	RW	Mapping	RPDO	Related Mode	-	Data Range	1 to (2 ³² -1)	Default	1

Take the ball screw as an example:

Minimum reference unit $f_c = 1$ mm

Lead $p_B = 10$ mm/r

Reduction ratio $n = 5:1$

Inovance 23-bit serial-type motor encoder resolution $P = 8388608$ (PPR)

The position factor is calculated as follows:

$$\begin{aligned}
 \text{Position factor} &= \frac{\text{Encoder resolution } P \times n}{p_B} \\
 &= \frac{8388608 \times 5}{10} \\
 &= \frac{41943040}{10} \\
 &= 4194304
 \end{aligned}$$

Therefore, 6091-1h = 4194304, and 6091-2h = 1, which means when the load shaft displacement is 1 mm, the motor displacement is 4194304.

Reduce the values of 6091-1h and 6091-2h to a point where there is no common divisor, and take the final value.

6 Troubleshooting

6.1 Faults and Warnings

Faults and warnings are divided into the following three levels based on severity: No.1 > No.2 > No.3.

- No. 1 non-resettable fault
- No. 1 resettable fault
- No. 2 resettable fault
- No. 3 resettable warning

"Resettable" means the keypad stops displaying the fault/warning once receiving the reset signal.

To reset a fault/warning, use one of the following two methods:

- Set 200D-02h to 1 (Fault reset).
- Set the rising edge of bit7 of the control word 0x6040 through the host controller.

To reset a No. 1 or No. 2 fault, turn off the S-ON signal and send a fault reset signal.

For No. 3 warnings, the servo drive resets warnings automatically after the warning source is cleared.

Related parameter

Para. No.	Name	Value Range	Function	Setting Condition	Effective Time	Default Value
200Dh-02h	Fault reset	0: No operation 1: Reset the fault and warning	Used to stop the keypad from displaying the fault/warning when a resettable fault/warning occurs. After fault/warning reset, 200Dh-02h is restored to 0 (No operation) immediately.	At stop	Immediately	0

- Solutions to faults and warnings occurred upon start

Start Process	Fault Symptom	Cause	Confirming Method
Switch on the control power supply (L1C, L2C) and main power supply (L1, L2, L3).	The LED neither lights up nor displays "ry".	1. The voltage of the control circuit power supply is abnormal.	Check whether the value of H0B-63 is 1. Measure the AC voltage between L1C and L2C.
		2. Phase loss occurs on the input power supply.	Check whether the value of H0B-63 is 2. Voltage must be present in all the phases of a three-phase 380 V power supply.
		3. The voltage of the main circuit power supply is abnormal.	Check whether the value of H0B-63 is 3. ◆ For single-phase 220 V models, measure the AC voltage between L1 and L2. The keypad displays "nr" when the DC bus voltage amplitude (between terminals P and N) of the main circuit power supply is lower than 235 V. ◆ For three-phase 220 V/380 V models, measure the AC voltage among L1, L2, and L3. The keypad displays "nr" when the DC bus voltage amplitude (between terminals P and N) of the main circuit power supply is lower than 235 V/451 V.
	4. The servo drive is faulty.	-	
	The keypad displays "Exxx.x".	See " 6.3 Solutions to Faults " and " 6.4 Solutions to Warnings " for solutions.	
	The keypad displays "ry" when preceding faults are cleared.		

6.2 Communication Faults and Warning Codes

■ List of fault codes

Fault	Display	Name	Type	Reset	Fault Range	Error Code (603Fh)	Auxiliary Code (203Fh)
E101	E101.0	System parameter error	No.1	No	Servo drive fault	0x6320	0x01010101
	E101.1	2000h/2001h parameter error	No.1	No	Servo drive fault	0x6320	0x11010101
E102	E102.0	FPGA communication initialization error	No.1	No	Servo drive fault	0x7500	0x01020102
	E102.8	Software version mismatch	No.1	No	Servo drive fault	0x7500	0x81020102
E104	E104.1	MCU operation timeout	No.1	No	Servo drive fault	0x7500	0x11040104
	E104.2	Current loop operation timeout	No.1	No	Servo drive fault	0x7500	0x21040104
	E104.4	MCU reference update timeout	No.1	No	Servo drive fault	0x7500	0x41040104
E108	E108.0	Parameter write error	No.2	Yes	Servo drive fault	0x5530	0x01080108
	E108.1	Parameter read error	No.2	Yes	Servo drive fault	0x5530	0x11080108
	E108.2	Invalid check on data written in EEPROM	No.2	Yes	Servo drive fault	0x5530	0x21080108
	E108.3	Invalid check on data read in EEPROM	No.2	Yes	Servo drive fault	0x5530	0x31080108
E120	E120.0	Unknown encoder type	No.1	No	Axis fault	0x7122	0x01200120
	E120.1	Unknown motor model	No.1	No	Axis fault	0x7122	0x11200120
	E120.2	Unknown drive model	No.1	No	Axis fault	0x7122	0x21200120
	E120.5	Motor current and drive current mismatch	No.1	No	Axis fault	0x7122	0x51200120
	E120.6	FPGA and motor model mismatch	No.1	No	Axis fault	0x7122	0x61200120
E122	E122.0	Multi-turn absolute encoder setting error	No.2	Yes	Axis fault	0x6320	0x01220122
	E122.1	Different DIs assigned with the same function	No.2	Yes	Axis fault	0x6320	0x11220122
	E122.3	Upper limit invalid	No.2	Yes	Axis fault	0x6320	0x31220122
E136	E136.0	Encoder parameter error	No.1	No	Axis fault	0x7305	0x01360136
	E136.1	Encoder communication error	No.1	No	Axis fault	0x7305	0x11360136
E140	E140.0	Encryption chip check error	No.1	No	Servo drive fault	0x0140	0x01400140
	E140.1	Encryption chip check failure	No.1	No	Servo drive fault	0x0140	0x01400140
E150	E150.0	STO signal input protection activated	No.1	Yes	Servo drive fault	0x0150	0x01500150
	E150.1	STO signal input error	No.1	Yes	Servo drive fault	0x0150	0x11500150
	E150.2	Abnormal voltage detected	No.1	Yes	Servo drive fault	0x0150	0x21500150
	E150.3	STO upstream optocoupler detection failure	No.1	Yes	Servo drive fault	0x0150	0x31500150
	E150.4	PWM Buffer detection failure	No.1	Yes	Servo drive fault	0x0150	0x41500150
E201	E201.0	Phase-P overcurrent	No.1	No	Servo drive fault	0x2312	0x02010201
	E201.1	Phase-U overcurrent	No.1	No	Axis fault	0x2312	0x12010201
	E201.2	Phase-V overcurrent	No.1	No	Axis fault	0x2312	0x22010201
	E201.4	Phase-N overcurrent	No.1	No	Servo drive fault	0x2312	0x42010201

Fault	Display	Name	Type	Reset	Fault Range	Error Code (603Fh)	Auxiliary Code (203Fh)
E208	E208.0	MCU position reference updated frequently	No.1	Yes	Axis fault	0x0208	0x02080208
	E208.2	Encoder communication timeout	No.1	Yes	Axis fault	0x0208	0x22080208
	E208.3	Current sampling fault	No.1	Yes	Axis fault	0x0208	0x32080208
	E208.4	FPGA current loop operation timeout	No.1	Yes	Axis fault	0x0208	0x42080208
E210	E210.0	Output short-circuited to ground	No.1	No	Axis fault	0x2330	0x02100210
E234	E234.0	Runaway protection	No.1	No	Axis fault	0x0234	0x02340234
E400	E400.0	Main circuit overvoltage	No.1	Yes	Servo drive fault	0x3210	0x04000400
E410	E410.0	Main circuit undervoltage	No.1	Yes	Servo drive fault	0x3220	0x04100410
E420	E420.0	Phase loss fault	No.2	Yes	Servo drive fault	0x3130	0x04200420
E430	E430.0	Control circuit undervoltage	No.2	Yes	Servo drive fault	0x0430	0x04300430
E500	E500.0	Motor overspeed	No.1	Yes	Axis fault	0x8400	0x05000500
	E500.1	Speed feedback overflow	No.1	Yes	Axis fault	0x8400	0x15000500
	E500.2	FPGA position feedback pulse overspeed	No.1	Yes	Axis fault	-	0x25000500
E602	E602.0	Angle auto-tuning error	No.1	Yes	Axis fault	0x0602	0x06020602
	E602.2	Wrong UVW phase sequence detected during angle auto-tuning	No.1	Yes	Axis fault	0x0602	0x26020602
E605	E605.0	Speed upon S-ON too high	No.1	Yes	Axis fault	0x8400	0x06050605
E620	E620.0	Motor overload	No.1	Yes	Axis fault	0x3230	0x06200620
E630	E630.0	Motor stall	No.1	Yes	Axis fault	0x7121	0x06300630
E640	E640.0	IGBT over-temperature	No.1	Yes	Axis fault	0x4210	0x06400640
	E640.1	Flywheel diode over-temperature	No.1	Yes	Axis fault	0x4210	0x06400640
E650	E650.0	Heatsink over-temperature	No.1	Yes	Axis fault	0x4210	0x06500650
E660	E660.0	Air-cooled motor over-temperature	No.1	Yes	Axis fault	0x4210	0x06600660
E661	E661.0	Auto-tuned gains too low	No.2	Yes	Axis fault	0x4210	0x06610661
E731	E731.0	Encoder battery failure	No.2	Yes	Axis fault	0x0661	0x07310731
E733	E733.0	Encoder multi-turn counting error	No.2	Yes	Axis fault	0x7305	0x07330733
E735	E735.0	Encoder multi-turn counting overflow	No.2	Yes	Axis fault	0x7305	0x07350735
E740	E740.2	Absolute encoder error	No.1	No	Axis fault	0x7305	0x27400740
	E740.3	Absolute encoder single-turn calculation error	No.1	No	Axis fault	0x7305	0x37400740
	E740.6	Encoder write error	No.1	No	Axis fault	0x7305	0x67400740
E755	E755.0	Nikon encoder communication failure	No.1	No	Axis fault	-	0x07550755
E760	E760.0	Encoder over-temperature	No.2	Yes	Axis fault	0x4210	0x07600760
E765	E765.0	Nikon encoder beyond the limit	No.1	No	Axis fault	-	0x07650765
EB00	EB00.0	Position deviation too large	No.2	Yes	Axis fault	0x8611	0x0B000B00
	EB00.1	Position deviation overflow	No.2	Yes	Axis fault	0x8611	0x1B000B00
EA33	EA33.0	Encoder read/write check error	No.1	No	Axis fault	0x7305	0x0A330A33

Fault	Display	Name	Type	Reset	Fault Range	Error Code (603Fh)	Auxiliary Code (203Fh)
EB01	EB01.1	Position reference increment too large for once	No.2	Yes	Axis fault	0x6320	0x1B010B01
	EB01.2	Position reference increment too large continuously	No.2	Yes	Axis fault	0x6320	0x2B010B01
	EB01.3	Reference overflow	No.2	Yes	Axis fault	0x6320	0x3B010B01
	EB01.4	EB01.4: Target position beyond upper/lower limit	No.2	Yes	Axis fault	0x6320	0x4B010B01
EE09	EE09.0	Software position limit setting error	No.2	Yes	Axis fault	0x6320	0x0E090E09
	EE09.1	Home setting error	No.2	Yes	Axis fault	0x6320	0x1E090E09
	EE09.2	Gear ratio beyond the limit	No.2	Yes	Axis fault	0x6320	0x2E090E09
	EE09.3	No synchronization signal	No.2	Yes	Axis fault	0x6320	0x3E090E09
	EE09.5	PDO mapping beyond the limit	No.2	Yes	Axis fault	0x6320	0x5E090E09
EE08	EE08.0	SYNC signal loss	No.2	Yes	Axis fault	0x0FFF	0x0E080E08
	EE08.1	Network status switchover error	No.2	Yes	Axis fault	0x0FFF	0x1E080E08
	EE08.2	IRQ loss	No.2	Yes	Axis fault	0x0FFF	0x2E080E08
	EE08.3	LAN cable connected improperly	No.2	Yes	Axis fault	0x0FFF	0x3E080E08
	EE08.4	Data frame loss protection error	No.2	Yes	Axis fault	0x0FFF	0x4E080E08
	EE08.5	Data frame transfer error	No.2	Yes	Axis fault	0x0FFF	0x5E080E08
	EE08.6	Data update timeout	No.2	Yes	Axis fault	0x0FFF	0x6E080E08
EE11	EE11.0	ESI check error	No.2	Yes	Servo drive fault	0x5530	0x0E110E11
	EE11.1	EEPROM read failure	No.2	Yes	Servo drive fault	0x5530	0x1E110E11
	EE11.2	EEPROM update failure	No.2	Yes	Servo drive fault	0x5530	0x2E110E11
EE12	EE12.0	EtherCAT external device error	No.1	No	Servo drive fault	0x0E12	0x0E120E12
EE13	EE13.0	Synchronization cycle setting error	No.2	Yes	Servo drive fault	0x6320	0x0E130E13
EE15	EE15.0	Number of synchronization cycle errors too large	No.2	Yes	Servo drive fault	0x0E15	0x0E150E15

■ List of warning codes

Warning	Display	Name	Type	Resettable or not	Fault Range	Error Code (603Fh)	Auxiliary Code (203Fh)
E121	E121.0	Invalid S-ON command	No.3	Yes	Warning	0x0121	0x01210121
E600	E600.0	Inertia auto-tuning failure	No.3	Yes	Warning	0x0600	0x06000600
E601	E601.0	Homing timeout	No.3	Yes	Warning	0x0601	0x06010601
	E601.1	Home switch error	No.3	Yes	Warning	0x0601	0x16010601
	E601.2	Homing mode setting error	No.3	Yes	Warning	0x6320	0x2601E602
E730	E730.0	Encoder battery warning	No.3	Yes	Warning	0x7305	0x07300730
E900	E900.0	Emergency stop	No.3	Yes	Warning	0x0900	0x09000900
E902	E902.0	Invalid DI setting	No.3	Yes	Warning	0x6320	0x09020902
	E902.1	Invalid DO setting	No.3	Yes	Warning	0x0902	0x19020902
E908	E908.0	Model identification check byte invalid	No.3	Yes	Warning	0x0908	0x09080908
E909	E909.0	Motor overload warning	No.3	Yes	Warning	0x3230	0x09090909
E920	E920.0	Regenerative resistor overload	No.3	Yes	Warning	0x3210	0x09200920

Warning	Display	Name	Type	Resettable or not	Fault Range	Error Code (603Fh)	Auxiliary Code (203Fh)
E922	E922.0	Resistance of external regenerative resistor too small	No.3	Yes	Warning	0x6320	0x09220922
E924	E924.0	Braking transistor over-temperature	No.3	Yes	Warning	0x3230	0x09240924
E941	E941.0	Parameter modifications not activated	No.3	Yes	Warning	0x6320	0x09410941
E942	E942.0	Parameter saved frequently	No.3	Yes	Warning	0x7600	0x09420942
E950	E950.0	Forward overtravel warning	No.3	Yes	Warning	0x5443	0x09500950
E952	E952.0	Reverse overtravel warning	No.3	Yes	Warning	0x5444	0x09520952
EA41	EA41.0	Torque ripple compensation failure	No.3	Yes	Warning	0x0A41	0x0A410A41

6.3 Solutions to Faults

■ E101.0: System parameter error

Direct cause:

The total number of parameters changes, which generally occurs after software update.

Parameter values in groups 2002h and above exceed the limit, which generally occurs after software update.

Root Cause	Confirming Method	Solution
1. The control power voltage drops instantaneously.	Check whether the voltage drops during control power (L1C, L2C) cutoff or whether instantaneous power failure occurs.	Restore system parameters to default values (2002-20h = 1), and write parameters again.
	Measure whether the voltage input to the control circuit cable during operation is within the following range: 220 V servo drive: Effective value: 220 V to 240 V Allowable deviation: -10% to +10% (198 V to 264 V) 380 V servo drive: Effective value: 380 V to 440 V Allowable deviation: -10% to +10% (342 V to 484 V)	Increase the power capacity or replace with a power supply of larger capacity. Restore system parameters to default values (2002-20h = 1), and write parameters again.
2. Instantaneous power failure occurs during parameter saving.	Check whether instantaneous power failure occurs during parameter saving.	Power on the system again, restore system parameters to default values (2002-20h = 1), and write parameters again.
3. The number of write operations exceeds the limit.	Check whether parameters are updated frequently through the host controller.	Change the write mode and write parameters again. If the servo drive is faulty, replace it.
4. The software has been updated.	Check whether the software has been updated.	Reset the servo drive model and the servo motor model, and restore system parameters to default values (2002-20h = 1).
5. The servo drive is faulty.	If the fault persists after several times of restart and parameter initialization, the servo drive is faulty.	Replace the servo drive.

■ E101.1: 2000h/2001h parameter error

Direct cause:

The total number of parameters changes, which generally occurs after software update.

Parameter values in group 2000h or 2001h exceed the limit, which generally occurs after software update.

Root Cause	Confirming Method	Solution
1. Instantaneous power failure occurs during parameter saving.	Check whether instantaneous power failure occurs during parameter saving.	Set the servo drive model (2001-0Bh) to a wrong value first and perform a power cycle, and then set the servo drive model to a correct value and perform a power cycle.
2. Instantaneous power failure occurs during the write operation.	Check whether instantaneous power failure occurs during writing motor parameters.	Write motor parameters using the software tool.
3. The software has been updated.	Check whether the software has been updated.	Set the servo drive model (2001-0Bh) to a wrong value first and perform a power cycle, and then set the servo drive model to a correct value and perform a power cycle.
4. The servo drive is faulty.	If the fault persists after repeated execution of steps 1 and 2 and multiple times of restart, the servo drive is faulty.	Replace the servo drive.

■ E102.0: FPGA communication initialization error

Direct cause:

The FPGA- or MCU-related hardware is damaged, resulting in communication failure between the MCU and FPGA.

Root Cause	Confirming Method	Solution
1. The FPGA is faulty. 2. The MCU cannot communicate with the FPGA.	The fault persists after the servo drive is powered off and on several times.	1. Confirm whether the FPGA has been upgraded. Ensure the programming is successful. 2. Replace the servo drive.

■ E102.8: Software version mismatch

Cause	Confirming Method	Solution
The software version of MCU or FPGA is wrong.	Check whether the MCU version (H01-00) is 9xx.x (the fourth digit displayed on the keypad is 9). Check whether the FPGA version (H01-01) is 9xx.x (the fourth digit displayed on the keypad is 9).	Contact Inovance for technical support and update to mutually-matching FPGA or MCU software.

■ E104.1: MCU operation timeout

Direct cause:

The access to MCU times out.

Root Cause	Confirming Method	Solution
1. The FPGA is faulty. 2. The communication handshake between FPGA and HOST is abnormal. 3. Access timeout occurs between HOST and the coprocessor.	The fault persists after the servo drive is powered off and on several times.	Replace the servo drive.

■ E104.2: Current loop operation timeout

Direct cause:

The operating time of the current loop exceeds the scheduling time. This fault is reported only in the commissioning stage.

Root Cause	Confirming Method	Solution
The time interval of MCU torque interrupt scheduling is abnormal.	The fault persists after the servo drive is powered off and on several times.	Replace the servo drive.

■ E104.4: Command update timeout

Direct cause:

Take the moment when entering the interrupt as the starting time. If the duration of the command-write operation in MCU is longer than the start time of the FPGA position and speed regulator, a warning will be reported.

Root Cause	Confirming Method	Solution
The interrupt time of the current loop is too long.	Check whether the interrupt time of the torque loop is too long through the software tool.	Hide unnecessary functions.

■ E108.0: Parameter write error

Direct cause:

Parameter values cannot be written to EEPROM.

Root Cause	Confirming Method	Solution
An error occurs when parameters are written to EEPROM.	Modify a certain parameter value, power off and on the servo drive again, and check whether the modified value is saved.	If the modified value is not saved and the fault persists after the servo drive is powered off and on again, replace the servo drive.

■ E108.1: Parameter read error

Direct cause:

Parameter values cannot be read in EEPROM.

Root Cause	Confirming Method	Solution
An error occurs when parameter values are read in EEPROM.	Modify a certain parameter value, power on the servo drive again, and check whether the modified value is saved.	If the modified value is not saved and the fault persists after the servo drive is powered off and on again, replace the servo drive.

■ E108.2: Invalid check on data written in EEPROM

Root Cause	Confirming Method	Solution
The check on the data written in EEPROM fails.	Modify a certain parameter value, power off and on the servo drive again, and check whether the modified value is saved.	If the modified value is not saved and the fault persists after the servo drive is powered off and on again, replace the servo drive.

■ E108.3: Invalid check on data read in EEPROM

Root Cause	Confirming Method	Solution
The check on the data read in EEPROM fails.	Modify a certain parameter value, power off and on the servo drive again, and check whether the modified value is saved.	If the modified value is not saved and the fault persists after the servo drive is powered off and on several times, replace the servo drive.

■ E120.0: Unknown encoder type

Direct cause:

The servo drive detects the encoder model during initialization upon power-on. If the encoder type does not comply with the requirements, the servo drive reports E120.0.

Root Cause	Confirming Method	Solution
The encoder model does not match the servo drive.	Check whether the encoder model is correct.	Replace the encoder.

■ E120.1: Unknown motor model

Direct cause:

The servo drive detects the motor model (H00-00) during initialization upon power-on. If the motor model does not exist, the servo drive reports E120.1.

Root Cause	Confirming Method	Solution
The motor model is set improperly.	Check whether H00-00 (Motor code) is set properly.	Set H00-00 to a proper value that matches the motor model.

■ E120.2: Unknown drive model

Direct cause:

The servo drive detects the servo drive model (H01-10) during initialization upon power-on. If the servo drive model does not exist, the servo drive reports E120.2.

Root Cause	Confirming Method	Solution
The servo drive model is set improperly.	Check whether H01-10 (Servo drive series number) is set properly.	Set H01-10 to a proper value that matches the servo drive model.

■ E120.5: Motor current and drive current mismatch

Direct cause:

The rated output current of the servo drive is higher than the rated current of the motor.

Root Cause	Confirming Method	Solution
The internal scaling value is abnormal.	Check whether the servo drive model is correct. If the rated current of the set servo drive model is larger than the rated current of the motor, calculation overflow will occur.	Replace with a servo drive of lower rated output current or a motor with higher rated current.

■ E120.6: FPGA and motor model mismatch

Direct cause:

1. The motor model is set improperly, causing mismatch and malfunction of the servo drive.
2. The motor model is set properly, but the motor encoder is not supported by the servo drive.

Root Cause	Confirming Method	Solution
The FPGA does not support the motor encoder.	Check whether the motor encoder is supported by the FPGA version (H01-01).	Update FPGA software or replace the motor encoder.

■ E122.0: Multi-turn absolute encoder setting error

Root Cause	Confirming Method	Solution
The motor does not match the absolute position mode or the motor code is set improperly.	Check the motor nameplate to see whether the motor is equipped with an absolute encoder. Check whether 200D-01h (Motor code) is set properly.	Set 200D-01h (Motor code) correctly according to the motor nameplate or replace with a matching motor.

■ E122.1: Different DIs assigned with the same function

Root Cause	Confirming Method	Solution
1. The same function is assigned to different DIs.	View 2003-03h, 2003-05h...2003-15h, 2017-01h, and 2017-03h...2017-1Fh to check whether they are assigned with the same DI function No.	Assign different DI functions to parameters that have been assigned with the same DI function. To enable such assignments, restart the control circuit or switch off the S-ON signal and send a "RESET" signal.
2. The DI function No. exceeds maximum setting number allowed for DI functions.	Check whether the MCU software has been updated.	Restore system parameters to default values (2002-20h = 1) and power off and on the servo drive again.

■ E122.3: Upper limit invalid

Root Cause	Confirming Method	Solution
The upper limit value of the mechanical single-turn position exceeds 2^{31} in the absolute position rotation mode.	Check the mechanical gear ratio setpoint, the upper limit of the mechanical single-turn position, and the electronic gear ratio in the absolute position rotation mode (H02-01 = 2).	Reset the mechanical gear ratio, the upper limit of mechanical single-turn position, and the electronic gear ratio to ensure the upper limit of the mechanical single-turn position (reference range) does not exceed 2^{31} .

■ E136.0: Encoder parameter error

Direct cause:

When the servo drive reads parameters in the encoder ROM, no parameters are saved or parameter values are inconsistent with the expected values.

Root Cause	Confirming Method	Solution
1. The servo drive model does not match the servo motor model.	View the servo drive and servo motor nameplates to check whether the devices used are Inovance SV630N series servo drive and servo motor.	Replace with the mutually-matching servo drive and servo motor.
2. A parameter check error occurs or no parameter is stored in the serial incremental encoder ROM.	Check whether the encoder cable provided by Inovance is used. For cable specifications, see “1.4 Cable Models” . Ensure the cable is intact and in good contact at both ends. Measure signals PS+, PS-, +5V and GND at both ends of the encoder cable and observe whether signals at both ends are consistent. For signal definitions, see “3 Wiring” .	Use the encoder cable provided by Inovance. Ensure the cable is connected to the motor securely and tighten the screws on the servo drive side. Use a new encoder cable if necessary. Do not bundle encoder cables together with power cables (RST, UVW). Lay encoder cables and power cables through different routes.
3. The servo drive is faulty.	The fault persists after servo drive is powered off and on again.	Replace the servo drive.

■ E136.1: Encoder communication error

Direct cause:

1. The encoder cable is disconnected.
2. The encoder communication suffers from interference.

Root Cause	Confirming Method	Solution
A fault occurs on the communication between FPGA and the motor encoder during initialization upon power-on.	Observe the value of H0B-28 to see whether it is not 0.	Check whether the encoder cable is connected properly. Check whether the motor model is set properly. Check whether H01-00 (MCU software version) and H01-01 (FPGA software version) are the correct ones.

■ E140.0: Encryption chip check error

Direct cause:

The check on the encryption chip fails.

Root Cause	Confirming Method	Solution
The encryption software is not programmed.	Power off and on again to check whether the fault persists.	Contact Inovance to program the encryption software again.

■ E140.1: Encryption chip check failure

Direct cause:

The check on the encryption chip fails.

Root Cause	Confirming Method	Solution
The key of the encryption chip is incorrect, causing failure in decrypting the Renesas chip.	1. Check the software version. Check whether encryption is programmed in the servo drive. 2. Check whether the encryption chip is abnormal.	Power off and on the servo drive again. If the fault persists, contact Inovance for maintenance.

■ E150.0: STO signal input protection activated

Direct cause:

The STO input protection applies (safety state).

Root Cause	Confirming Method	Solution
1. The STO is activated.	Check whether the STO function is activated.	There is no need to take any actions. Clear the fault through the fault reset function after the STO terminal is restored.
2. The STO power supply is abnormal.	Check whether the 24 V power supply of the STO works normally.	Measure the 24 V power supply of the STO to check whether it is stable. Tighten the cables that are loose or disconnected.
3. The STO is inactive.	The fault persists after preceding actions are taken.	Replace the servo drive.



NOTE

When H0A-21 is set to 0, STO displays the STO state. When H0A-21 is set to 1, STO displays E150.0.

■ E150.1: STO signal input error

Direct cause:

The single-channel input of STO is invalid.

Root Cause	Confirming Method	Solution
1. The STO power supply is abnormal.	Check whether the 24 V power supply of the STO works normally.	Measure the 24 V power supply of the STO to check whether it is stable. Tighten the cables that are loose or disconnected.
2. The STO input resistor is abnormal.	After STO is triggered, only one STO signal is sent to MCU after the 24 V power supply is cut off due to input resistor drift.	Replace the servo drive.
3. The STO is inactive.	The fault persists after preceding actions are taken.	Replace the servo drive.

■ E150.2: Abnormal voltage detected

Direct cause:

The MCU monitors the 5 V power supply for the PWM Buffer to detect whether overvoltage and undervoltage occurs. If the voltage is abnormal, E150.2 will be displayed.

Root Cause	Confirming Method	Solution
The 5 V power supply for the Buffer is abnormal.	Check the 5 V power supply.	Replace the servo drive.

■ E150.3: STO upstream optocoupler detection failure

Direct cause:

Short circuit occurs on the optocoupler of the upstream hardware circuit of STO.

Root Cause	Confirming Method	Solution
Short circuit occurs on the upstream optocoupler of STO1 or STO2.	The servo drive does not display E150.0 when the 24 V power supply is powered off and on again.	Replace the servo drive.

■ E150.4: PWM Buffer detection failure

Direct cause:

An error occurs on the PWM Buffer integrated circuit during initialization detection upon power-on (the PWM signal cannot be blocked).

Root Cause	Confirming Method	Solution
The Buffer fails to block the PWM signals.	The fault persists after the servo drive is powered off and on several times.	Replace the servo drive.

■ E201.0: Phase-P overcurrent

Direct cause:

A excessively high current flows through the positive pole of the DC-AC circuit.

Root Cause	Confirming Method	Solution
1. Gains are set improperly, leading to motor oscillation. 2. The encoder is wired improperly, aging, or connected loosely. 3. The servo drive is faulty. 4. Overcurrent occurs on the regenerative resistor.	<ul style="list-style-type: none"> ◆ Check whether vibration or sharp noise occurs during start and operation of the motor, or view the "Current feedback" in the software tool. ◆ Check whether encoder cables provided by Inovance are used. Check whether the encoder cable is aging, corroded, or connected loosely. ◆ Switch off the S-ON signal and rotate the motor shaft manually, observing whether the value of 200B-12h changes when the shaft rotates. ◆ Unplug the motor cable. The fault persists after the servo drive is powered off and on again. ◆ Check whether the resistance of the external regenerative resistor is too small or the regenerative resistor is short-circuited (between terminals P ⊕ and C). 	<ul style="list-style-type: none"> ◆ Adjust the gains. ◆ Re-solder, tighten, or replace encoder cables. ◆ Replace the servo drive. ◆ Select the resistance and model of the regenerative resistor again. ◆ Perform wiring again.

■ E201.1: Phase-U overcurrent

■ Direct cause: A large current exceeding the threshold is detected in phase U.

Cause	Confirming Method	Solution
1. Motor cables are in poor contact. 2. Motor cables are grounded. 3. UVW cables of the motor are short-circuited. 4. The motor is damaged due to over-temperature.	<ul style="list-style-type: none"> ◆ Check whether both ends of servo drive power cables and motor cables on servo drive UVW sides are loose and fall off. ◆ After confirming the servo drive power cables and motor cables are connected properly, measure whether the insulation resistance between the servo drive UVW ends and the PE cable is at MΩ level. ◆ Unplug the motor cables and check whether short circuit occurs among UVW cables and whether burrs exist in the wiring. ◆ Unplug the motor cables and measure whether the resistance among UVW cables of the motor are balanced. 	<ul style="list-style-type: none"> ◆ Tighten the cables that are loose or fall off. ◆ Replace the motor in case of poor insulation. ◆ Connect the motor cables properly. ◆ Replace the motor if the resistance among UVW cables of the motor is unbalanced.

■ E201.2: Phase-V overcurrent

■ Direct cause: A large current exceeding the threshold is detected in phase V.

Root Cause	Confirming Method	Solution
1. Motor cables are in poor contact. 2. Motor cables are grounded. 3. UVW cables of the motor are short-circuited. 4. The motor is damaged due to over-temperature.	<ul style="list-style-type: none"> ◆ Check whether both ends of servo drive power cables and motor cables on servo drive UVW sides are loose and fall off. ◆ After confirming the servo drive power cables and motor cables are connected properly, measure whether the insulation resistance between the servo drive UVW ends and the PE cable is at MΩ level. ◆ Unplug the motor cables and check whether short circuit occurs among UVW cables and whether burrs exist in the wiring. ◆ Unplug the motor cables and measure whether the resistance among UVW cables of the motor are balanced. 	<ul style="list-style-type: none"> ◆ Tighten the cables that are loose or fall off. ◆ Replace the motor in case of poor insulation. ◆ Connect the motor cables properly. ◆ Replace the motor if the resistance among UVW cables of the motor is unbalanced.

■ E201.4: Phase-N overcurrent

Direct cause:

- Direct cause: A large current exceeding the threshold is detected in phase N

Root Cause	Confirming Method	Solution
1. Motor cables are in poor contact. 2. Motor cables are grounded. 3. UVW cables of the motor are short-circuited. 4. The motor is damaged due to over-temperature.	<ul style="list-style-type: none"> ◆ Check whether both ends of servo drive power cables and motor cables on servo drive UVW sides are loose and fall off. ◆ After confirming the servo drive power cables and motor cables are connected properly, measure whether the insulation resistance between the servo drive UVW ends and the PE cable is at MΩ level. ◆ Unplug the motor cables and check whether short circuit occurs among UVW cables and whether burrs exist in the wiring. ◆ Unplug the motor cables and measure whether the resistance among UVW cables of the motor are balanced. 	<ul style="list-style-type: none"> ◆ Tighten the cables that are loose or fall off. ◆ Replace the motor in case of poor insulation. ◆ Connect the motor cables properly. ◆ Replace the motor if the resistance among UVW cables of the motor is unbalanced. ◆ Perform wiring again.

■ E208.0: MCU position reference updated frequently

Find the fault cause through the internal fault code (200B-2Eh).

Root Cause	Confirming Method	Solution
1. MCU communication times out.	200B-2Eh = 1208: The internal integrated circuit is damaged.	Replace the servo drive.
2. FPGA operation times out.	200B-2Eh = 0208: Figure out the cause according to cause 1.	

■ E208.2: Encoder communication timeout

Root Cause	Confirming Method	Solution
The servo drive fails to receive the data fed back by the encoder in three consecutive cycles.	<ul style="list-style-type: none"> ◆ Check bit12 of H0B-30. ◆ The encoder cable is connected improperly. ◆ The encoder cable is loose. ◆ The encoder cable is too long. ◆ The encoder communication suffers from interference. ◆ The encoder is faulty. 	<ul style="list-style-type: none"> ◆ Check whether the motor model is correct. ◆ Check whether encoder cable is in proper condition. ◆ Check whether the encoder version (H00-04) is set properly. ◆ If servo drive operates improperly, replace it.

■ E208.3: Current sampling fault

Root Cause	Confirming Method	Solution
Phase-U and phase-V current samplings are abnormal.	Check whether there is large equipment generating interferences on site and whether there are multiple interference sources in the cabinet. The internal current sampling integrated circuit is damaged.	<ul style="list-style-type: none"> ◆ Check whether the servo drive and motor are grounded and shielded properly. ◆ Install magnetic ring on the motor power cables and encoder cables. ◆ Replace the servo drive.

■ E208.4: FPGA current loop operation timeout

Cause:

The operation time of the current loop exceeds the interval threshold.

Root Cause	Confirming Method	Solution
The FPGA operation times out.	200B-2Eh (Internal fault code) = 4208: The current loop operation times out.	Turn off some unnecessary functions to reduce the operating time of the current loop.

■ E210.0: Output short-circuited to ground

Direct cause:

The servo drive detects abnormal motor phase current or bus voltage during self-check upon power-on.

Root Cause	Confirming Method	Solution
1. Power cables (UVW) of the servo drive are short-circuited to ground.	Unplug motor cables and check whether the servo drive power cables (UVW) are short circuited to ground (PE).	Re-connect or replace the servo drive power cables.
2. The motor is short-circuited to ground.	After confirming servo drive power cables and motor cables are connected securely, check whether the insulation resistance between servo drive UVW terminals and the grounding cable (PE) is at MΩ-level.	Replace the servo motor.
3. The servo drive is faulty.	Disconnect servo drive power cables from the servo drive. The fault persists after the servo drive is powered off and on several times.	Replace the servo drive.

■ E234.0: Runaway Protection

Direct cause:

The torque reference direction is opposite to the speed feedback direction in the torque control mode.

The speed feedback direction is opposite to the speed reference direction in the position or speed control mode.

Root Cause	Confirming Method	Solution
1. The UVW cables are connected in the wrong phase sequence.	Check whether UVW phase sequence on the servo drive side is consistent with that on the motor side.	Connect UVW cables according to the correct phase sequence.
2. An error occurs on the initial phase detection of the motor rotor due to interference signals upon power-on.	The UVW phase sequence is correct, but E234.0 occurs when the servo drive is enabled.	Power off and on the servo drive again.
3. The encoder model is wrong or the wiring is incorrect.	Check the servo drive and servo motor nameplates to check whether the devices used are Inovance SV630N series servo drive and servo motor.	Replace with the mutually-matching servo drive and servo motor. If you use Inovance SV630N series servo drive and servo motor, ensure that 2000-01h is set to 14000. Check the motor model, encoder model, and encoder cable connections again.

Root Cause	Confirming Method	Solution
4. The encoder cable is connected improperly, corroded, or loose.	Check whether the encoder cable provided by Inovance is used. Check whether the cable is aging, corroded, or loose. Switch off the S-ON signal, rotate the motor shaft manually, and check whether the value of 200B-0Bh (Electrical angle) changes when the motor shaft rotates.	Re-solder, tighten or replace the encoder cable.
5. The gravity load is too heavy in vertical axis applications.	Check whether the vertical axis load is too heavy. Adjust brake parameters 2002-0Ah...2002-0Dh and check whether the fault can be cleared.	Reduce the load of the vertical axis, improve the stiffness level or hide this fault without affecting the safety performance or normal use.
6. Improper parameter settings cause excessive vibration.	The stiffness level is too high, leading to excessive vibration.	Set a proper stiffness level to avoid excessive vibration.

■ E400.0: Main circuit overvoltage

Direct cause:

The DC bus voltage between terminals P and N exceeds the overvoltage threshold.

220 V servo drive:

Normal value: 310 V

Overvoltage threshold: 420 V

380 V servo drive:

Normal value: 540 V

Overvoltage threshold: 760 V

Root Cause	Confirming Method	Solution
1. The voltage input to the main circuit is too high.	Check the power input specifications of the servo drive and measure whether the voltage input to main circuit cables (RST) on the servo drive side is within the following range: ◆ 220 V servo drive: Effective value: 220 V to 240 V Allowable deviation: -10% to +10% (198 V to 264 V) ◆ 380 V servo drive: Effective value: 380 V to 440 V Allowable deviation: -10% to +10% (342 V to 484 V)	Replace or adjust the power supply according to the specified ranges.
2. The power supply is unstable or affected by the lightning strike.	Check whether the power input to the servo drive is unstable, affected by lightning strike or is within the preceding range.	Connect a surge protection device and then switch on the control circuit and main circuit. If the fault persists, replace the servo drive.

Root Cause	Confirming Method	Solution
3. The regenerative resistor fails.	<p>If an internal regenerative resistor is used (2002-1Ah = 0), check whether terminals P and D are jumpered. If yes, measure the resistance between terminals C and D.</p> <p>If an external regenerative resistor is used (2002-1Ah = 1, 2), measure the resistance between terminals P ⊕ and C.</p> <p>For specifications of the regenerative resistor, see “1.1.4 Specifications of the Regenerative Resistor”.</p>	<ul style="list-style-type: none"> ◆ If the resistance is "∞" (infinite), the regenerative resistor is disconnected internally. ◆ If an internal regenerative resistor is used, replace with an external regenerative resistor (2002-1Ah = 1, 2) and remove the jumper between terminals P and D. Select an external regenerative resistor of the same resistance and equal or higher power than the internal one. ◆ If an external regenerative resistor is used, replace with a new one and connect the new one between terminals P ⊕ and C. <p>Set 2002-1Bh (Power of external regenerative resistor) and 2002-1Ch (Resistance of external regenerative resistor) according to the specifications of the external regenerative resistor used.</p>
4. The resistance of the external regenerative resistor is too large, and energy absorption during braking is insufficient.	<p>Measure the resistance of the external regenerative resistor between terminals P ⊕ and C, and compare the measured value with the recommended value.</p>	<p>Connect a new external regenerative resistor of the recommended resistance between terminals P ⊕ and C.</p> <p>Set 2002-1Bh (Power of external regenerative resistor) and 2002-1Ch (Resistance of external regenerative resistor) according to the specifications of the external regenerative resistor used.</p>
5. The motor is in abrupt acceleration/ deceleration status and the maximum braking energy exceeds the energy absorption value.	<p>Confirm the acceleration/deceleration time during operation and measure whether the DC bus voltage between terminals P and N exceeds the fault threshold during deceleration.</p>	<p>Ensure the voltage input to the main circuit is within the specified range, and then increase the acceleration/deceleration time if allowed.</p>
6. The bus voltage sampling value deviates greatly from the measured value.	<p>Check whether the bus voltage (200B-1Bh) detected is within the following range:</p> <p>220 V servo drive: 200B-1Bh > 420 V</p> <p>380 V servo drive: 200B-1Bh > 760 V</p> <p>Measure whether the DC bus voltage detected between terminals P and N is close to the value displayed in 200B-1Bh.</p>	<p>Contact Inovance for technical support.</p>
7. The servo drive is faulty.	<p>The fault persists after main circuit is powered off and on several times.</p>	<p>Replace the servo drive.</p>

■ E410.0: Main circuit undervoltage

Direct cause:

The DC bus voltage between terminals P and N is lower than the undervoltage threshold.

220 V servo drive:

Normal value: 310 V

Undervoltage threshold: 200 V (or 180 V for 7.5 W servo drives)

380 V servo drive:

Normal value: 540 V

Undervoltage threshold: 380 V

Root Cause	Confirming Method	Solution
1. The main circuit power supply is unstable or fails.	Check the power input specifications of the servo drive. Measure whether the voltage input to the main circuit cables is within the following range:	Increase the power capacity.
2. Instantaneous power failure occurs.	◆ 220 V servo drive: Effective value: 220 V to 240 V Allowable deviation: -10% to +10% (198 V to 264 V) ◆ 380V servo drive Effective value: 380 V to 440 V Allowable deviation: -10% to +10% (342 V to 484 V) All the three phases must be measured.	
3. Voltage drop occurs on the power supply during operation.	Monitor the input voltage of the servo drive to check whether the same power supply is used to power up other devices, resulting in insufficient power capacity and voltage drop.	
4. Phase loss: A single-phase power supply is used for a three-phase servo drive.	Check whether main circuit cables are connected properly and whether the phase loss fault detection (200A-01h) is hidden.	Replace the cables and connect the main circuit cables properly. Three-phase: R, S, T
5. The servo drive is faulty.	Check whether the bus voltage (200B-1Bh) detected is within the following range: 220 V servo drive: 200B-1Bh < 200 V (or < 180 V for 750 W servo drives) 380 V servo drive: 200B-1Bh < 380 V The fault persists after the main circuit is powered off and on several times.	Replace the servo drive.

■ E420.0: Phase loss fault

Direct cause:

Phase loss occurs on a three-phase servo drive.

Root Cause	Confirming Method	Solution
1. The three-phase input cables are connected improperly.	Check whether cables between the power supply side and main circuit input terminals (R/S/T) are in good condition and connected properly.	Replace the cables and connect the main circuit cables properly.
2. A single-phase power supply is applied to a three-phase servo drive.	Check the power input specifications of the servo drive and measure whether the voltage input to the main circuit is within the following range:	A three-phase servo drive of 0.75 kW (2001-03h = 5) is allowed to run under a single-phase power supply. If the input voltage complies with the specifications, set 200A-01h to 2 (Power input phase loss warning and fault inhibited). If input voltage does not comply with the specifications, replace or adjust the power supply.
3. The three-phase power supply is unbalanced or the voltage of all the three phases is too low.	◆ 220 V servo drive: Effective value: 220 V to 240 V Allowable deviation: -10% to +10% (198 V to 264 V) ◆ 380 V servo drive: Effective value: 380 V to 440 V Allowable deviation: -10% to +10% (342 V to 484 V) All the three phases must be measured.	
4. The servo drive is faulty.	The fault persists after the main circuit (L1, L2, L3) is powered off and on several times.	Replace the servo drive.

■ E430.0: Control circuit undervoltage

Direct cause:

The control circuit power supply is lower than the undervoltage threshold.

220 V servo drive:

Normal value: 310 V

Undervoltage threshold: 190 V

380 V servo drive:

Normal value: 540 V

Undervoltage threshold: 350 V

Root Cause	Confirming Method	Solution
1. The power supply of the control circuit is unstable or the voltage of the power supply drops.	Check whether the fault occurs during control circuit power supply (L1C, L2C) cutoff or during instantaneous power failure.	Restore system parameters to default values (2002-20h = 1), and write parameters again.
	Measure whether the voltage input to the control circuit cable is within the following range: ◆ 220 V servo drive: Effective value: 220 V to 240 V Allowable deviation: -10% to +10% (198 V to 264 V) ◆ 380 V servo drive: Effective value: 380 V to 440 V Allowable deviation: -10% to +10% (342 V to 484 V)	Increase the power capacity.
2. The control circuit cables are in poor contact.	Check whether control circuit cables are connected properly and measure whether the voltage of the control circuit cable on the servo drive side is within the preceding range.	Re-connect or replace the cables.

■ E500.0: Motor overspeed

Direct cause:

The actual speed of the servo motor exceeds the overspeed threshold.

Root Cause	Confirming Method	Solution
1. The UVW phase sequence of motor cables is incorrect.	Check whether UVW phase sequence on the servo drive side is consistent with that on the motor side.	Connect UVW cables according to the correct phase sequence.
2. 200A-09h is set improperly.	Check whether the overspeed threshold is lower than the maximum motor speed required in actual applications. Overspeed threshold = 1.2 x Maximum motor speed (200A-09h = 0) Overspeed threshold = 200A-09h (the setpoint of 200A-09h is not 0 and less than 1.2 times the maximum motor speed).	Reset the overspeed threshold according to actual mechanical requirements.

Root Cause	Confirming Method	Solution
3. The input reference is higher than the overspeed threshold.	<p>Check whether the motor speed corresponding to the input reference exceeds the overspeed threshold.</p> <p>◆ Position control mode</p> <p>In CSP mode, view the gear ratio 6091-01h/6091-02h to check the position reference increment per synchronization cycle and convert it to the corresponding speed value.</p> <p>In PP mode, view the gear ratio 6091-01h/6091-02h and determine the value of 6081h (Profile velocity).</p> <p>In HM mode, view the gear ratio 6091-01h/6091-02h, and determine the values of 6099-01h and 6099-02h.</p> <p>◆ Speed control mode:</p> <p>View the gear ratio (6091h), the target velocity (60FFh), the speed limit values (2006-09h and 2006-0Ah), and the maximum profile velocity (607Fh).</p> <p>◆ Torque control mode:</p> <p>View the speed limits defined by 2007-14h and 2007-15h and check the corresponding speed limits.</p>	<p>◆ Position control mode</p> <p>In CSP mode, decrease the position reference increment per synchronization cycle. The host controller should handle the position ramp when generating references.</p> <p>In PP mode, decrease the value of 6081h or increase the acceleration and deceleration ramps (6083h and 6084h).</p> <p>HM: Decrease the values of 6099-01h and 6099-02h, or increase the acceleration/ deceleration ramp (609Ah).</p> <p>Reduce the gear ratio according to actual conditions.</p> <p>◆ Speed mode:</p> <p>Decrease the target velocity, speed limit, and gear ratio. In PV mode, increase the speed ramps in 6083h and 6084h. In CSV mode, the host controller should handle the speed ramp.</p> <p>◆ Torque control mode:</p> <p>Set the speed limit to a value lower than the overspeed threshold.</p>
4. The motor speed overshoots.	Check whether the speed feedback exceeds the overspeed threshold using the software tool.	Adjust the gains or operating conditions of the machine.
5. The servo drive is faulty.	The fault persists after servo drive is powered off and on again.	Replace the servo drive.

■ E500.1: Speed feedback overflow

Direct cause:

The FPGA speed measurement overflows.

Root Cause	Confirming Method	Solution
The FPGA speed measurement is abnormal.	Check whether bit9 of H0B-30 is 1.	<p>◆ The speed feedback is abnormal. Check whether the encoder version (H00-04) is proper.</p> <p>◆ Replace the encoder cables.</p> <p>◆ The encoder cables suffer from interference. Re-connect the grounding cable and the shielded cable or install a magnetic ring on the encoder cable.</p>

■ E500.2: FPGA position feedback pulse overspeed

Direct cause:

Overspeed occurs on the FPGA position feedback pulse.

Root Cause	Confirming Method	Solution
The MCU detects excessive pulse increment fed back by the FPGA.	<ol style="list-style-type: none"> 1. Check whether the value of H0B-17 changes abruptly. 2. Check whether the communication between the servo drive and the encoder suffers from interference. 	Modify the value of H0A-70 (Overspeed threshold). The default value of H0A-70 is 0. Use the maximum motor speed as the threshold for excessive pulse increment.

■ E602.0: Angle auto-tuning error

Direct cause:

Abnormal jitter occurs on the encoder feedback during angle auto-tuning.

Root Cause	Confirming Method	Solution
An encoder feedback error occurs.	Check whether the encoder communication suffers from interference.	Check the wiring of the encoder.

■ E602.2: Wrong UVW phase sequence detected during angle auto-tuning

Direct cause:

A wrong UVW phase sequence is detected during angle auto-tuning.

Root Cause	Confirming Method	Solution
The UVW cables are connected reversely, which is detected during angle auto-tuning.	-	Exchange the cables of any two phases of UVW and perform auto-tuning again.

■ E605.0: Speed upon S-ON too high

Root Cause	Confirming Method	Solution
Speeds of servo drives in sizes A and B exceed the rated speed upon servo ON.	Check whether the motor is in the power generating state.	Reduce the speed and switch on the S-ON signal again.

■ E620.0: Motor overload

Direct cause:

The accumulative heat of the servo motor reaches the fault threshold.

Root Cause	Confirming Method	Solution
1. The motor and encoder cable is connected improperly.	Check the wiring among the servo drive, servo motor and encoder according to the correct wiring diagram.	Connect cables according to the correct wiring diagram. It is recommended to use the cables provided by Inovance. If you use customized cables, ensure such cables are made and connected based on the wiring instructions.
2. The load is too heavy. The motor keeps outputting an effective torque higher than the rated value.	Check the overload characteristics of the servo drive or servo motor. Check whether the average load ratio (200B-0DH) keeps exceeding 100.0%.	Replace with a servo drive of large capacity and a matching servo motor, or reduce the load and increase the acceleration/deceleration time.
3. Acceleration/Deceleration is too frequent or the load inertia is too large.	Calculate the mechanical inertia ratio or perform inertia auto-tuning, and view the value of 2008-10h (Load inertia ratio). Confirm the individual operation cycle for cyclic operation.	Increase the acceleration/ deceleration time of an individual operation cycle.
4. Gains are improper or the stiffness level is too high.	Observe whether the motor vibrates and generates abnormal noise during operation.	Adjust the gains.
5. The servo drive or motor models are set improperly.	Check the motor model in 2000-06h and servo drive model in 2001-0Bh.	Read the servo drive nameplate and set the servo drive model and motor model properly.

Root Cause	Confirming Method	Solution
6. The motor is stalled due to mechanical factors, resulting in overload during operation.	Check the reference and motor speed (200B-01h) through the software tool or the keypad: <ul style="list-style-type: none"> ◆ Reference in the position control mode: 200B-0Eh (Input position reference counter) ◆ Reference in the speed control mode: 200B-02h (Speed reference) ◆ Reference in the torque control mode: 200B-03h (Internal torque reference) Check whether the reference value is not 0 but the motor speed is 0.	Eliminate mechanical factors.
7. The servo drive is faulty.	The fault persists after servo drive is powered off and on again.	Replace the servo drive.



NOTE

When E620.0 occurs, stop the servo drive for at least 30s before further operations.

■ E630.0: Motor stall

Direct cause:

The motor speed actual value is lower than 10 RPM but the torque reference reaches the limit, and such status persists for the time defined by 200A-21h.

Root Cause	Confirming Method	Solution
1. Power output phase (UVW) loss or incorrect phase sequence occurs on the servo drive.	Perform motor trial run without load and check cable connections and the phase sequence.	Re-connect the cables according to the correct wiring diagram or replace the cables.
2. The motor parameters (especially the pole pairs) are set improperly and motor angle auto-tuning is not performed.	Read parameters in group H00 to check whether the pole pairs are set properly. Perform angle auto-tuning on the motor several times and check whether the value of H00-28 remains unchanged.	Modify motor parameter values.
3. The communication commands suffer from interference.	Check whether jitter occurs on the commands sent from the host controller and whether EtherCAT communication suffers from interference.	Check whether the communication circuit between the host controller and the servo drive suffers from interference.
4. The motor is stalled due to mechanical factors.	Check the reference and motor speed (H0B-00) through the software tool or the keypad. <ul style="list-style-type: none"> ◆ Reference in the position control mode: H0B-13 (Input position reference counter) ◆ Reference in the speed control mode: H0B-01 (Speed reference) ◆ Reference in the torque control mode: H0B-02 (Internal torque reference) Check whether the reference value is not 0 but the motor speed is 0. Check the current feedback (torque reference) waveform.	Check whether any mechanical part gets stuck or eccentric.



When E630.0 occurs, stop the servo drive for at least 30s before further operations.

NOTE

■ E640.0: IGBT over-temperature

Direct cause: The IGBT temperature reaches the fault threshold defined by H0A-18.

Root Cause	Confirming Method	Solution
1. The ambient temperature is too high. 2. The servo drive is powered off frequently to reset the overload fault. 3. The fan is damaged. 4. The installation direction and clearance of the servo drive are improper. 5. The servo drive is faulty.	<ul style="list-style-type: none"> ◆ Measure the ambient temperature. ◆ View the fault log (set 200B-22h and check 200B-23h) to see whether an overload fault or warning (E620.0, E630.0, E650.0, E909.0, E920.0, and E922.0) is reported. ◆ Check whether the fan rotates during operation. ◆ Check whether the servo drive is installed properly. ◆ The servo drive is restarted 5 min after power-off, but the fault persists. 	<ul style="list-style-type: none"> ◆ Improve cooling conditions to lower down the ambient temperature. ◆ Change the fault reset mode and perform reset 30s after overload. Increase the capacities of the servo drive and servo motor. Increase the acceleration/deceleration time and reduce the load. ◆ Replace the servo drive. ◆ Install the servo drive according to the installation requirements. ◆ Replace the servo drive.



When E640.0 occurs, stop the servo drive for at least 30s before further operations.

NOTE

■ E640.1: Flywheel diode over-temperature

Direct cause: The temperature of the flywheel diode reaches the fault threshold defined by H0A-18.

Root Cause	Confirming Method	Solution
1. The ambient temperature is too high. 2. The servo drive is powered off frequently to reset the overload fault. 3. The fan is damaged. 4. The installation direction and clearance of the servo drive are improper. 5. The servo drive is faulty.	<ul style="list-style-type: none"> ◆ Measure the ambient temperature. ◆ View the fault log (set 200B-22h and check 200B-23h) to see whether an overload fault or warning (E620.0, E630.0, E650.0, E909.0, E920.0, and E922.0) is reported. ◆ Check whether the fan rotates during operation. ◆ Check whether the servo drive is installed properly. ◆ The servo drive is restarted 5 min after power-off, but the fault persists. 	<ul style="list-style-type: none"> ◆ Improve cooling conditions to lower down the ambient temperature. ◆ Change the fault reset mode and perform reset 30s after overload. Increase the capacities of the servo drive and servo motor. Increase the acceleration/deceleration time and reduce the load. ◆ Replace the servo drive. ◆ Install the servo drive according to the installation requirements. ◆ Replace the servo drive.



When E640.1 occurs, stop the servo drive for at least 30s before further operations.

NOTE

■ E650.0: Heatsink over-temperature

Direct cause:

The power module temperature of the servo drive is higher than the over-temperature protection threshold.

Root Cause	Confirming Method	Solution
1. The ambient temperature is too high.	Measure the ambient temperature.	Improve cooling conditions to lower down the ambient temperature.

Root Cause	Confirming Method	Solution
2. The servo drive is powered off frequently to reset the overload fault.	View the fault records: Check whether overload fault (set 200B-22h and view 200B-23h) or warning (E620.0, E630.0, E650.0, E909.0, E920.0, and E922.0) is reported.	Change the fault reset mode and perform reset 30s after overload. Increase the capacity of the servo drive and servo motor. Increase the acceleration/deceleration time and reduce the load.
3. The fan is damaged.	Check whether the fan rotates during operation.	Replace the servo drive.
4. The installation direction and clearance of the servo drive are improper.	Check whether the servo drive is installed properly.	Install the servo drive according to the installation requirements.
5. The servo drive is faulty.	The servo drive is restarted 5 min after power-off, but the fault persists.	Replace the servo drive.



NOTE

When E650.0 occurs, stop the servo drive for at least 30s before further operations.

■ E660.0: Air-cooled motor over-temperature

Direct cause:

The temperature of the air-cooled motor is too high.

Root Cause	Confirming Method	Solution
The temperature of the air-cooled motor is too high.	Measure whether the temperature of the air-cooled motor is too high.	Cool the motor down.

■ E661.0: Auto-tuned gains too low

Root Cause	Confirming Method	Solution
1. Gains obtained from STune or ETune are wrong.	-	1. Set the notch manually if vibration cannot be suppressed. 2. Check whether the positioning threshold is too small. Increase the reference acceleration/deceleration time. 3. Modify the electronic gear ratio to improve the reference resolution, or increase the reference filter time in the parameter configuration interface and check whether cyclic vibration occurs on the machine.
2. Vibration cannot be suppressed and the internal gains reach the lower limit.		

■ E731.0: Encoder battery failure

Direct cause:

The battery voltage of the absolute encoder is lower than 2.8 V.

Root Cause	Confirming Method	Solution
The battery is not connected during power-off.	Check whether the battery is connected during power-off.	Set 200D-15h to 1 to clear the fault.
The battery voltage of the encoder is too low.	Measure the battery voltage.	Replace with a new battery of the matching voltage.

■ E733.0: Encoder multi-turn counting error

Direct cause:

The encoder multi-turn counting is wrong.

Root Cause	Confirming Method	Solution
The encoder is faulty.	Set 200D-15h to 2 to clear the fault. E733.0 persists after the servo drive is powered off and on again.	Replace the servo motor.

■ E735.0: Encoder multi-turn counting overflow

Direct cause:

Multi-turn counting overflow occurs on the absolute encoder.

Root Cause	Confirming Method	Solution
The number of forward revolutions exceeds 32767 or the number of reverse revolutions exceeds 32768.	Check whether the value of H0B-70 (Number of absolute encoder revolutions) is 32767 or 32768 when the servo drive works in the absolute position linear mode (H02-01 = 1).	Set H0D-20 (Absolute encoder reset selection) to 2 (Reset the encoder fault and multi-turn data) and power on the servo drive again. Perform homing if necessary.

■ E740.2: Absolute encoder error

Direct cause:

Communication timeout occurs on the absolute encoder.

Root Cause	Confirming Method	Solution
The communication between the servo drive and the encoder is abnormal.	Check whether the value of H0B-28 (Absolute encoder fault information given by FPGA) is not 0.	<ul style="list-style-type: none"> ◆ Check whether H00-00 (Motor code) is set properly. ◆ Check whether the encoder cable is connected properly. ◆ Check whether the servo drive and servo motor are grounded properly. You can install a magnetic ring on the encoder cable to reduce interference.

■ E740.3: Absolute encoder single-turn calculation error

Root Cause	Confirming Method	Solution
An internal fault occurs on the encoder.	Check whether bit7 of H0B-28 is 1.	<ul style="list-style-type: none"> ◆ Check whether the encoder version (H00-04) is proper. ◆ Check whether the encoder cable is in proper condition. ◆ Replace the servo motor.

■ E740.6: Encoder write error

Direct cause:

A write error occurs on the encoder.

Root Cause	Confirming Method	Solution
An error occurs during writing the position offset after angle auto-tuning.	-	Check whether the encoder cable shield and the grounding cable are connected properly.

■ E755.0: Nikon encoder communication failure

Direct cause:

Nikon encoder communication fails.

Root Cause	Confirming Method	Solution
1. An encoder communication error or encoder fault is detected after servo drive initialization is done upon power-on. 2. E755.0 will be reported when a multi-turn Nikon encoder that carries no battery for a long time is powered on again.	<ul style="list-style-type: none"> ◆ Check whether the encoder is wired correctly. ◆ Check whether there is large equipment generating interferences on site and whether connectors are loose or cables are broken. 	<ul style="list-style-type: none"> ◆ Ensure the encoder cable is connected properly. ◆ Take proper shielding measures if the interference source does exist.

■ E760.0: Encoder over-temperature

Root Cause	Confirming Method	Solution
The temperature of the absolute encoder is too high.	Measure the encoder or motor temperature.	Switch off the S-ON signal to cool the encoder down.

■ E765.0: Nikon encoder beyond the limit

Root Cause	Confirming Method	Solution
Over-temperature, overspeed, or EEPROM access error is detected in the encoder.	The fault is detected by the Nikon encoder, and the servo drive only displays the fault.	Set H0D-21 to 1 to clear the fault.

■ EB00.0: Position deviation too large

Direct cause:

The position deviation is larger than the value defined by 6065h in the position control mode.

Root Cause	Confirming Method	Solution
1. Power output (UVW) phase loss or incorrect phase sequence occurs on the servo drive.	Perform motor trial run without load and check the cable connections.	Re-connect the cables according to the correct wiring diagram or replace the cables.
2. The servo drive UVW cables or the encoder cable is disconnected.	Check the wiring.	Re-connect the cables. The UVW phase sequence on the servo drive side must be consistent with that on the motor side. Replace with new cables if necessary and ensure the cables are connected properly.
3. The motor is stalled due to mechanical factors.	Check the reference and motor speed (200B-01h) through the software tool or the keypad: Reference in the position control mode: 200B-0Eh (Input position reference counter) Reference in the speed control mode: 200B-02h (Speed reference) Reference in the torque control mode: 200B-03h (Internal torque reference) Check whether the reference value is not 0 but the motor speed is 0.	Eliminate mechanical factors.
4. The servo drive gains are too low.	Check the position loop gain and speed loop gain of the servo drive. 1st gain set: 2008-01h to 2008-03h 2nd gain set: 2008-04h to 2008-06h	Adjust the gains manually or perform gain auto-tuning.

Root Cause	Confirming Method	Solution
5. The position reference increment is too large.	<p>Position control mode:</p> <ul style="list-style-type: none"> ◆ In CSP mode, view the gear ratio 6091-01h/6091-02h to check the position reference increment per synchronization cycle and convert it to the corresponding speed value. ◆ In PP mode, view the gear ratio 6091-01h/6091-02h and determine the value of 6081h (Profile velocity). ◆ In HM mode, view the gear ratio 6091-01h/6091-02h, and determine the values of 6099-01h and 6099-02h. 	<ul style="list-style-type: none"> ◆ In CSP mode, decrease the position reference increment per synchronization cycle. The host controller should handle the position ramp when generating references. ◆ In PP mode, decrease the value of 6081h or increase the acceleration/deceleration ramp (6083h/6084h). ◆ In HM mode, decrease the values of 6099-01h and 6099-02h, or increase the acceleration/deceleration ramp (609Ah). <p>Decrease the gear ratio according to actual conditions.</p>
6. The value of 6065h (Following error window) is too small in relative to the operating condition.	Check whether the value of 6065h is too small.	Increase the value of 6065h.
7. The servo drive or servo motor is faulty.	Monitor the operating curves through the oscilloscope function of the software tool: position reference, position feedback, speed reference, and torque reference	If the position reference is not 0 but the position feedback is always 0, replace the servo drive or the servo motor.

■ EB00.1: Position deviation overflow

Direct cause:

The position deviation is too large.

Root Cause	Confirming Method	Solution
1. Power output (UVW) phase loss or incorrect phase sequence occurs on the servo drive.	Perform motor trial running without load and check the cable connections.	Re-connect the cables according to the correct wiring diagram or replace the cables.
2. The servo drive U/V/W cables or the encoder cable is disconnected.	Check the wiring.	Re-connect the cables. The U/V/W phase sequence on the servo drive side must be consistent with that on the motor side. Replace with new cables if necessary and ensure the cables are connected properly.
3. The motor is stalled due to mechanical factors.	<p>Check the reference and motor speed (200B-01h) through the software tool or the keypad:</p> <p>Reference in the position control mode: 200B-0Eh (Input position reference counter)</p> <p>Reference in the speed control mode: 200B-02h (Speed reference)</p> <p>Reference in the torque control mode: 200B-03h (Internal torque reference)</p> <p>Check whether the reference value is not 0 but the motor speed is 0.</p>	Eliminate mechanical factors.
4. The servo drive gains are too low.	<p>Check the position loop gain and speed loop gain of the servo drive.</p> <p>1st gain set: 2008-01h to 2008-03h</p> <p>2nd gain set: 2008-04h to 2008-06h</p>	Adjust the gains manually or perform gain auto-tuning.

Root Cause	Confirming Method	Solution
5. The position reference increment is too large.	Position control mode: ◆ In CSP mode, view the gear ratio 6091-01h/6091-02h to check the position reference increment per synchronization cycle and convert it to the corresponding speed value. ◆ In PP mode, view the gear ratio 6091-01h/6091-02h and determine the value of 6081h (Profile velocity). ◆ In HM mode, view the gear ratio 6091-01h/6091-02h, and determine the values of 6099-01h and 6099-02h.	◆ In CSP mode, decrease the position reference increment per synchronization cycle. The host controller should handle the position ramp when generating references. ◆ In PP mode, decrease the value of 6081h or increase the acceleration/deceleration ramp (6083h/6084h). ◆ In HM mode, decrease the values of 6099-01h and 6099-02h, or increase the acceleration/deceleration ramp (609Ah). Decrease the gear ratio according to actual conditions.
6. The value of 6065h (Following error window) is too small in relative to the operating condition.	Check whether the value of 6065h is too small.	Increase the value of 6065h.
7. The servo drive or the servo motor is faulty.	Monitor the operating curves through the oscilloscope function of the software tool: position reference, position feedback, speed reference, and torque reference	If the position reference is not 0 but the position feedback is always 0, replace the servo drive or the servo motor.

■ EA33.0: Encoder read/write check error

Direct cause:

Internal parameters of the encoder are abnormal.

Root Cause	Confirming Method	Solution
1. The serial incremental encoder cable is disconnected or loose.	Check the encoder cable connection.	Check for wrong connection, disconnection and poor contact of the encoder cable. Route the motor cable and encoder cable through different routes.
2. An error occurs when reading/writing the RS485 encoder parameters.	If the fault persists after the servo drive is powered off and on several times, the encoder is faulty.	Replace the servo motor.

■ EB01.1: Position reference increment too large for once

Cause	Confirming Method	Solution
The target position increment is too large.	Check the variation value between two adjacent target positions using the software tool.	1. Check whether the maximum motor speed fulfills the application requirements. If yes, reduce the target position reference increment, in order to lower the profile reference speed. If not, replace the servo motor. 2. Before switching the mode or enabling the servo drive, check whether the target position is aligned with current position feedback. 3. The communication time sequence of the host controller is abnormal, leading to slave data reception error. Check the communication time sequence of the host controller.

■ EB01.2: Position reference increment too large continuously

Direct cause:

The target position increment exceeds the limit value N times consecutively.

Root Cause	Confirming Method	Solution
The target position increment is too large.	Check the variation value between two adjacent target positions by using the software tool.	<ol style="list-style-type: none"> 1. Check whether the maximum motor speed fulfills the application requirements. If yes, reduce the target position reference increment, in order to lower the profiled reference speed. If not, replace the servo motor. 2. Before switching the mode or enabling the servo drive, check whether the target position is aligned with current position feedback. 3. The communication time sequence of the host controller is abnormal, leading to slave data reception error. Check the communication time sequence of the host controller.

■ EB01.3: Command overflow

Cause	Confirming Method	Solution
The target position is still in the process of transmission when the servo limit or software limit signal is activated and the 32-bit upper/low limit is reached.	Check whether the host controller continues sending commands after the overtravel warning occurs.	<ol style="list-style-type: none"> 1. Check the servo limit signal (bit0 and bit1 of 60FD recommended) through the host controller. 2. Stop sending limit direction references when the servo limit signal is active detected by the host controller.

■ EB01.4: Target position beyond upper/lower limit

Cause	Confirming Method	Solution
The target position exceeds the upper/lower limit of the position in the single-turn absolute mode.	Check whether the target position setpoint is within the single-turn upper/lower limit.	Set the target position to a value within the upper/lower limit.

■ EE09.0: Software position limit setting error

Root Cause	Confirming Method	Solution
The lower limit of the software is larger than or equal to the upper limit.	Check the values of 607D-01 and 607D-02.	Reset the values of 607D-01 and 607D-02 and ensure the former is lower than the latter.

■ EE09.1: Home setting error

Direct cause:

The home offset exceeds the upper/lower limit.

Root Cause	Confirming Method	Solution
1. The home offset is beyond the software limit.	The home offset is beyond the software limit when the encoder works in the incremental mode, absolute linear mode, or single-turn absolute mode.	Set the home offset to a value within the software limit.
2. The home offset is beyond the upper/lower limit in the rotation mode.	The home offset is beyond the mechanical single-turn upper/lower limit when the encoder works in the rotation mode.	Set the home offset to a value within the mechanical single-turn upper/low limit.

■ EE09.2: Gear ratio beyond the limit

Direct cause:

The electronic gear ratio exceeds the following limit:

(0.001, 4000 x Encoder resolution/10000)

Root Cause	Confirming Method	Solution
The set electronic gear ratio exceeds the preceding range.	Check whether the ratio of 6091-01h to 6091-02h exceeds the preceding range.	Set the gear ratio to a value within the preceding range.

■ EE09.3: No synchronization signal

Direct cause:

The MCU does not receive the synchronization signal when the servo communication is switched to OP status.

Root Cause	Confirming Method	Solution
1. The communication synchronization clock is configured improperly.	Replace with another master (such as Beckhoff or Omron PLCs) and perform tests to compare between different masters.	Rectify improper configurations.
2. The IN/OUT port of EtherCAT communication is connected reversely.	Check whether the IN/OUT port is connected reversely.	Connect the IN and OUT ports according to the correct sequence.
3. The slave controller integrated circuit is damaged.	If the problem persists after the master is replaced, measure the synchronization signal generated from the slave controller integrated circuit with an oscilloscope. If there is no signal, the slave controller integrated circuit is damaged.	Contact Inovance for replacing the slave controller integrated circuit.
4. The MCU pins are damaged.	Test the synchronization signal generated from the slave controller integrated circuit with an oscilloscope. If there is a signal, the pin of the MCU integrated circuit is damaged.	Contact Inovance for replacing the MCU integrated circuit.

■ EE09.5: PDO mapping beyond the limit

Root Cause	Confirming Method	Solution
The number of the mapping objects in TPDO or RPDO exceeds 10.	Check the number of self-indexes configured in 1600h or 1A00h.	The number of the mapping objects in TPDO or RPDO cannot exceed 10.

6.4 Solutions to Warnings

■ E121.0: Invalid S-ON command

Direct cause:

The S-ON signal is set repeatedly.

Root Cause	Confirming Method	Solution
1. The servo drive is enabled internally at the same time when the S-ON signal is activated through communication.	Check whether the S-ON signal is sent from the host controller when auxiliary functions (200D-03h, 200D-04h, 200D-0Ch) are used.	Switch off the S-ON signal sent from the host controller.
2. The S-ON signal is sent from the DI and the software tool simultaneously.	Check whether the S-ON signal is sent from the DI terminal and the software tool simultaneously.	Switch off the redundant S-ON signal.

■ E600.0: Inertia auto-tuning failure

Direct causes and solutions:

1. The vibration cannot be suppressed. Enable vibration suppression manually (H09-12 to H09-23) to eliminate the vibration.
2. The auto-tuned values fluctuate dramatically. Increase the maximum operating speed and reduce the acceleration/deceleration time during ETune operation. For screw mechanisms, shorten the stroke.
3. Mechanical connections of the load are loose or eccentric. Rectify the mechanical fault.
4. A warning occurs during auto-tuning and causes interruption. Clear the fault and perform inertia auto-tuning again.
5. The vibration cannot be suppressed if the load carries large inertia. In this case, increase the acceleration/deceleration time to ensure the motor current is not saturated.

■ E601.0: Homing timeout

Direct cause:

The home is not found within the time defined by 2005-24h.

Root Cause	Confirming Method	Solution
1. The home switch fails.	There is only high-speed search but no low-speed search during homing. After high-speed searching for the home, the servo drive keeps low-speed searching in the reverse direction.	1. If the home switch is used as the home signal, a hardware DI is used as the deceleration point, check whether FunIN.31 (HomeSwitch) is assigned to a certain DI in group 2003h and then check the wiring of the DI. Manually change the DI logic and observe the value of 200B-04h to see whether the servo drive receives the corresponding DI level changes. If not, the DI is wired improperly. If yes, a fault occurs during homing. Perform the homing operation correctly. 2. If Z signal is used as the home signal, a hardware DI is used as the deceleration point, check whether DI functions (FunIN.14 for positive position limit; FunIN.15 for negative position limit; FunIN.31 for home switch) are set properly and then check the wiring of the DI. Manually change the DI logic and observe the value of 200B-04h to see whether the servo drive receives the corresponding DI level changes. If not, the DI is wired improperly. If yes, a fault occurs during homing. Perform the homing operation correctly.
2. The set homing duration is too short.	Check whether the value of 2005-24h (Homing time limit) is too small.	Increase the value of 2005-24h.
3. The speed in high-speed searching for the home switch signal is too low.	Check the distance between the initial position of homing and the home switch. Then check whether the value of 6099-01h is too small, resulting in a prolonged homing process.	Increase the value of 6099-01h.

■ E601.1: Homing switch error

Root Cause	Confirming Method	Solution
The home switch is set improperly.	Check whether the limit signals at both sides are activated simultaneously. Check whether the limit signal and the deceleration point signal/home signal are both activated.	Set the position of the hardware switch properly.

■ E601.2: Homing mode setting error

Root Cause	Confirming Method	Solution
The homing method (0x6098) is set to a value outside the range of [-2 to 14] in the absolute position single-turn mode (H02-01 = 4).	Check the setpoint of 0x6098.	Set 0x6098 to a value within the range.
The homing method (0x6098) is set to a value outside the ranges of [-2, 14], [17, 30], and [33,35] when the absolute position single-turn mode is not used.	Check the setpoint of 0x6098.	Set 0x6098 to a value within the range.

■ E730.0: Encoder battery warning

Root Cause	Confirming Method	Solution
The encoder battery voltage is lower than 3.0 V.	Measure the battery voltage.	Replace with a new battery of matching voltage.

■ E900: Emergency stop

Direct cause:

The logic of the DI (including hardware DI and virtual DI) assigned with FunIN.34 (EmergencyStop) is active.

Root Cause	Confirming Method	Solution
The DI function 34 (FunIN.34: Emergency stop) is triggered.	Check whether the logic of the DI assigned with FunIN.34 is valid.	Check the operating mode and clear the DI signal without affecting the safety performance.

■ E902.0: Invalid DI setting

Direct cause:

The DI function is set to an invalid value.

Root Cause	Confirming Method	Solution
The function of either DI1 to DI5 is set to an invalid value.	Check whether 2003-03h, 2003-05h, 2003-07h...2003-09h, and 2003-0Bh are set to invalid values.	Set the DI function to a valid value.

■ E902.1: Invalid DO setting

Direct cause:

The DO function is set to an invalid value.

Root Cause	Confirming Method	Solution
The function of either DO1 to DO3 is set to an invalid value.	Check whether 2004-01h, 2004-03h, and 2004-05h are set to invalid values.	Set the DO function to a valid value.

■ E908.0: Model identification check failure

Direct cause:

The first two check bytes of model identification are incorrect, indicating the attempt to read model identification parameters fails.

Root Cause	Confirming Method	Solution
1. The model identification parameters are not written.	The warning persists after the servo drive is powered off and on again.	1. Write the model identification parameters again.
2. The check bytes of model identification are incorrect.		2. Set H01-72 to 1 to hide the model identification function.

■ E909.0: Motor overload warning

Direct cause:

The accumulative heat of the motor reaches the warning threshold (90% of the maximum allowable heat).

Root Cause	Confirming Method	Solution
1. The motor and encoder cables are connected improperly or in poor contact.	Check the wiring among the servo drive, servo motor and encoder according to the correct wiring diagram.	Connect cables based on the correct wiring diagram. It is recommended to use the cables provided by Inovance. If you use customized cables, ensure such cables are made and connected based on the wiring instructions.
2. The load is too heavy. The motor keeps outputting an effective torque higher than the rated value.	Check the overload characteristics of the servo drive or servo motor. Check whether the average load ratio (200B-0Dh) keeps exceeding 100.0%.	Replace with a servo drive of large capacity and a matching servo motor, or reduce the load and increase the acceleration/deceleration time.
3. The acceleration/ deceleration is too frequent or the load inertia is too large.	Check the mechanical inertia ratio or perform inertia auto-tuning. Then view the value of 2008-10h (Load inertia ratio). Confirm the individual operation cycle when the servo motor operates cyclically.	Increase the acceleration/deceleration time.
4. The gains are improper or the stiffness level is too high.	Observe whether the motor vibrates and generates abnormal noise during operation.	Adjust the gains.
5. The servo drive or motor models are set improperly.	Check the motor model in 2000-06h and the servo drive model in 2001-0Bh.	Read the servo drive nameplate and set the servo drive model and motor model properly.
6. The motor is stalled due to mechanical factors, resulting in overload during operation.	Check the reference and motor speed (200B-01h) through the software tool or the keypad: ◆ Reference in the position control mode: 200B-0Eh (Input position reference counter) ◆ Reference in the speed control mode: 200B-02h (Speed reference) ◆ Reference in the torque control mode: 200B-03h (Internal torque reference) Check whether the reference value is not 0 but the motor speed is 0.	Rectify mechanical factors.
7. The servo drive is faulty.	Power off and on the servo drive again.	If the fault persists after restart, replace the servo drive.



NOTE

When E909.0 occurs, stop the servo drive for at least 30s before further operations.

■ E920.0: Regenerative resistor overload

Direct cause:

The accumulative heat of the regenerative resistor reaches the warning threshold (90% of the maximum allowable heat).

Root Cause	Confirming Method	Solution
1. The external regenerative resistor is disconnected or loose.	Remove the external regenerative resistor and measure whether the resistance of the resistor is " ∞ " (infinite).	Replace with a new external regenerative resistor and measure its resistance. If its resistance is consistent with the nominal value, connect it between terminals P ⊕ and C.
	Measure whether the resistance between terminals P ⊕ and C is " ∞ " (infinite).	Prepare a new cable and connect the external regenerative resistor between terminals P ⊕ and C.
2. The cable between terminals P and D is shorted or disconnected when an internal regenerative resistor is used.	Measure whether the resistance between terminals P and D is " ∞ " (infinite).	Prepare a new cable to short terminals P and D.
3. The setting of 2002-1Ah is incorrect when an external regenerative resistor is used.	Check the setpoint of 2002-1Ah. Measure the resistance of the external regenerative resistor connected between terminals P ⊕ and C. Check whether the resistance is too large by comparing it with value listed in "Table 5-3 Specifications of the regenerative resistor" .	Set 2002-1Ah to a proper value according to "5.4.3 Regenerative Resistor Settings" : 2002-1Ah = 1 (External, naturally ventilated) 2002-1Ah = 2 (External, forcible cooling)
4. The resistance of the external regenerative resistor used is too large.		Select a proper regenerative resistor according to Table 5-3.
5. The value of 2002-1Ch (Resistance of external regenerative resistor) is larger than the resistance of the external regenerative resistor used.	Check whether the value of 2002-1Ch is larger than the resistance of the external regenerative resistor connected between terminals P ⊕ and C.	Set 2002-1Ch according to the resistance of the external regenerative resistor used.
6. The voltage input to the main circuit exceeds the specified range.	Check whether the voltage input to the main circuit cable on the servo drive side is within the following range: ◆ 220 V servo drive: Effective value: 220 V to 240 V Allowable deviation: -10% to +10% (198 V to 264 V) ◆ 380 V servo drive: Effective value: 380 V to 440 V Allowable deviation: -10% to +10% (342 V to 484 V)	Adjust or replace the power supply according to the specified range.

Root Cause	Confirming Method	Solution
7. The load moment of inertia ratio is too large.	Perform inertia auto-tuning according to Inertia Auto-tuning or calculate the total mechanical inertia according to mechanical parameters. Check whether the actual load inertia ratio exceeds 30.	Select an external regenerative resistor of large capacity and set 2002-1Bh (Power of external regenerative resistor) according to the actual value. Select a servo drive of larger capacity. Reduce the load if allowed. Increase the acceleration/deceleration time if allowed. Increase the cyclic deceleration interval of the servo drive if allowed.
8. The motor speed is too high, and deceleration is not done within the required time. The motor is in continuous deceleration status during cyclic motion.	View the motor speed curve during cyclic motion and check whether the motor is in the deceleration status for a long time.	
9. The capacity of the servo drive or regenerative resistor is insufficient.	View the single-cycle speed curve of the motor and calculate whether the maximum braking energy can be absorbed completely.	
10. The servo drive is faulty.	-	Replace the servo drive.

■ E922.0: Resistance of the external regenerative resistor too small

Direct cause:

The value of 2002-1Ch (Resistance of external regenerative resistor) is smaller than the value of 2002-16h (Minimum permissible resistance of regenerative resistor).

Root Cause	Confirming Method	Solution
When an external regenerative resistor is used (2002-1Ah = 1, 2), the resistance of the external regenerative resistor is smaller than the minimum value allowed by the servo drive.	Measure the resistance of the external regenerative resistor connected between terminals P ⊕ and C and check whether it is smaller than the value of 2002-16h.	<ul style="list-style-type: none"> ◆ If yes, replace with an external regenerative resistor that matches the servo drive and set 2002-1Ch (Resistance of external regenerative resistor) according to the resistance of the external regenerative resistor used. ◆ If not, set 2002-1Ch according to the resistance of the external regenerative resistor used.

■ E924.0: Braking transistor over-temperature

Cause:

The estimated temperature of the braking transistor is higher than H0A-38 (Maximum protection threshold)

■ E941.0: Parameter modifications not effective

Root Cause	Confirming Method	Solution
The parameters modified are those whose "Effective time" is "Next power-on".	Check whether modifications of these parameters can be effective at next power-on.	Power on the servo drive again.

■ E942.0: Parameter saved frequently

Direct cause:

The total number of parameters modified simultaneously exceeds 200.

Root Cause	Confirming Method	Solution
A large number of parameters are modified and saved frequently to EEPROM (200E-02h = 1, 3).	Check whether parameters are modified quickly and frequently through the host controller.	Check the operation mode. For parameters that need not be saved in EEPROM, set 200E-02h to 0.

■ E950.0: Forward overtravel warning

Cause	Confirming Method	Solution
1. The logic of the DI assigned with FunIN.14 is valid (Forward driving inhibited).	Check whether a DI in group 2003h is assigned with FunIN.14 and check whether the DI logic of the corresponding bit of 200B-04h (Monitored DI status) is valid.	Check the operation mode and on the prerequisite of ensuring safety, send a reverse run command or rotate the motor to deactivate the logic of the DI assigned with FunIN.14.
2. The servo drive position feedback reaches the positive software position limit.	Check whether the position feedback (0x6064) is close to the value of 0x607D-02.	Ensure the travel distance of the load is within the software position limit.

■ E952.0: Reverse overtravel warning

Root Cause	Confirming Method	Solution
1. The logic of the DI assigned with FunIN.15 (Reverse driving inhibited) is valid.	Check whether a DI in group 2003h is assigned with FunIN.15 and check whether the DI logic of the corresponding bit of 200B-04h (Monitored DI status) is valid.	Check the operation mode and on the prerequisite of ensuring safety, send a forward run command or rotate the motor to deactivate the logic of the DI assigned with FunIN.15.
2. The servo drive position feedback reaches the negative software position limit.	Check whether the position feedback (0x6064) is close to the value of 0x607D-02.	Ensure the travel distance of the load is within the software position limit.

■ EA41.0: Torque ripple compensation failure

Root Cause	Confirming Method	Solution
The attempt to write torque ripple compensation parameters to the encoder fails. An encoder data read/write error occurs.	Check the wiring of the encoder.	If the fault persists after several attempts, contact Inovance for technical support.

6.5 Solutions to Communication Faults

This section describes solutions to communication faults.

■ EE08.0: SYNC signal loss

Direct cause:

The SYNC signal is turned off when the EtherCAT network is in the OP state.

Root Cause	Confirming Method	Solution
The SYNC signal is not generated due to hardware errors.	Check whether the SYNC signal cycle is 0 through the oscilloscope in the software tool.	Replace the servo drive. Contact Inovance for maintenance.

■ EE08.1: Network status switchover error

Direct cause:

The EtherCAT network status switches from OP to other status when the servo drive is enabled.

Cause	Confirming Method	Solution
This fault is caused by mal-operation of the master or the operator.	Check whether the master switches the network status when the servo drive is enabled.	Check the network status switchover program of the host controller.

■ EE08.2: IRQ loss

For servo drives with H01-00 (MCU software version) = 902.0 or earlier, the fault causes include all the causes for EE08.0, EE08.01, and EE08.3...EE08.6, without differentiation.

For servo drives with H01-00 (MCU software version) = 902.1 or later, fault causes are further differentiated, which means EE08.2 will not be reported.

■ EE08.3: LAN cable connected improperly

Direct cause:

The LAN cable is connected to the servo drive network port improperly. (The low 16 bits of H0E-29 is the number of IN port loss events. The high 16 bits of H0E-29 is the number of OUT port loss events.)

Cause	Confirming Method	Solution
The physical connection of the data link is unstable or the process data is lost due to plug-in/plug-out of the LAN cable.	Check: 1) whether the LAN cable of the servo drive is connected securely. 2) whether violent vibration occurs on site. 3) whether the LAN cable is plugged in or out. 4) whether the LAN cable provided by Inovance is used.	Check the connection condition of the network port through the value change of H0E-29 and replace with a new LAN cable.

■ EE08.4: Data frame loss protection error

Direct cause:

The PDO data is corrupted due to EMC interference or inferior LAN cable.

Cause	Confirming Method	Solution
The data is lost due to EMC interference, poor quality of the LAN cable or poor connection.	Check whether the high 16 bits of H0E-25 have values that are increasing.	Check whether the servo drive is grounded properly and rectify the EMC interference. Check whether the LAN cable used is the one designated by Inovance. Check whether the LAN cable is connected properly.

■ EE08.5: Data frame transfer error

Direct cause:

As error data frames are generated from the upstream slave, the downstream device receives invalid data frames.

Cause	Confirming Method	Solution
The upstream station detects that the data frame has been corrupted and marked, which is then transferred to the slave, leading to a warning report.	Check whether a process unit error occurs due to transfer error (H0E-27) or invalid frame (H0E-28) upon occurrence of the fault and check whether no counting is performed in RX-ERR of Port0.	Check the upstream station to locate the fault cause.

■ EE08.6: Data update timeout

Direct cause:

The slave is in the OP status and does not receive the data frame in a long time.

Cause	Confirming Method	Solution
The data frame is lost or aborted in the upstream station or the performance of the master is poor.	Check through the software tool whether the phase difference between SYNC and IRQ exceeds the value of H0E-22 multiplied by the communication cycle.	Check whether the operation load of the master CPU is too large. Increase the communication time or set H0E-22 to a large value. Check whether link loss occurs on the upstream station.

■ EE11.0: ESI check error

Direct cause:

The attempt to upload the XML file during EtherCAT communication fails.

Root Cause	Confirming Method	Solution
1. The XML file is programmed in the EEPROM. 2. The XML file in the EEPROM is modified unexpectedly.	Check whether the XML version displayed in H0E-96 is normal.	Program the XML file.

■ EE11.1: EEPROM read failure

Direct cause:

The EEPROM communication of external EtherCAT devices fails.

Root Cause	Confirming Method	Solution
The EtherCAT data in the EEPROM cannot be read.	This fault persists after the servo drive is powered off and on several times.	Replace the servo drive.

■ EE11.2: EEPROM update failure

Direct cause:

The communication is normal but the message in the EEPROM is wrong or lost.

Root Cause	Confirming Method	Solution
The EtherCAT data in the EEPROM cannot be updated.	This fault persists after the servo drive is powered off and on several times.	Replace the servo drive.

■ EE12.0: External devices of EtherCAT being abnormal

Direct cause:

The EtherCAT network cannot be initialized.

Root Cause	Confirming Method	Solution
1. The FPGA firmware is not programmed.	Check whether the value of 2001-02h is 09xx.Y.	Program the FPGA firmware.
2. The servo drive is faulty.	Check whether the servo drive is faulty.	Replace the faulty servo drive.

■ EE13.0: Synchronization cycle setting error

Cause	Confirming Method	Solution
The synchronization cycle is not a integer multiple of 125 μ s or 250 μ s.	Check the setpoint of the synchronization cycle in the controller.	Set the value of synchronization cycle to an integer multiple of 125 μ s or 250 μ s.

■ EE15.0: Number of synchronization cycle errors too large

Direct cause:

The number of synchronization cycle errors exceed the threshold.

Root Cause	Confirming Method	Solution
Excessive number of synchronization cycle errors occur on the controller.	Measure the synchronization cycle of the controller using a digital oscilloscope or the oscilloscope function in the software tool.	Increase the value of 200E-21h.

7 Appendix

7.1 Standards Compliance

7.1.1 CE Certification

- CE Mark



Figure 7-1 CE Mark

- 1) The CE mark indicates compliance with European safety and environmental regulations. The European Norm includes the Machinery Directive for machinery manufacturers, the Low Voltage Directive for electronics manufacturers, and EMC directive for electromagnetic interference control.
- 2) The CE mark is required for engaging in commercial business (production, importation, and distribution) in Europe.
- 3) This servo drive carries the CE mark and complies with the following directives:
Low Voltage Directive: 2014/35/EU
EMC Directive: 2014/30/EU
- 4) Machines and devices integrated with this servo drive must also be CE certified.
- 5) The integrator who integrates this servo drive into other products and attaches CE mark to the final assembly has the responsibility of ensuring compliance with CE standards and the European Norm.

7.1.2 Low Voltage Directive Compliance

This servo drive has been tested according to EN 61800-5-1, and it complies with the Low Voltage Directive.

Abide by the following requirements to enable machines and devices integrated with this servo drive to comply with the Low Voltage Directive.

- Installation location

Install the servo drive in places with overvoltage and pollution respectively not higher than category 3 and severity 2 in accordance with EN 60664.

- Fuse on the input side (primary side)

To prevent accidents caused by short circuit, connect an UL-compliant fuse on the input side. Select the fuse according to the following table.

Table 7-1 Recommended fuse model

Servo Drive Series	Servo Drive Model	Rated Input Current	Bussmann FWH Series (UL-compliant)
Single-phase 220 V			
Size A	SV630NS1R6I	2.3	FWP-15B
	SV630NS2R8I	4	FWP-20B
Size B	SV630NS5R5I	7.9	FWP-20B
Size C	SV630NS7R6I	5.1	FWP-20B
Size D	SV630NS012I	8	FWP-35B
Three-phase 220 V			
Size C	SV630NS7R6I	5.1	FWP-20B
Size D	SV630NS012I	8	FWP-35B
Three-phase 380 V			
Size C	SV630NT3R5I	2.4	FWP-15B
	SV630NT5R4I	3.6	FWP-20B
Size D	SV630NT8R4I	5.6	FWP-20B
	SV630NT012I	8	FWP-35B
Size E	SV630NT017I	12	FWP-50B
	SV630NT021I	16	FWP-70B
	SV630NT026I	21	FWP-125B

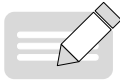
**NOTE**

- ◆ When the fuse burns or the wiring breaker trips, do not switch on the power supply or operate the machine immediately. Check the cable connections and the models of peripherals to identify the cause. If the cause cannot be identified, contact Inovance. Do not switch on the power supply or operate the machine without permission before identifying the cause.
- ◆ Each input cable of the servo drive must be connected to a fuse. When a fuse burns, replace all the fuses.

- In-cabinet installation to prevent intrusion of unwanted objects

The SV630N series servo drive must be installed in a cabinet with the fire-proof housing that provides effective electrical and mechanical protection. The installation must conform to local laws and regulations and related IEC requirements.

- Grounding

For a servo drive of class 400 V, connect the neutral point of the servo drive power supply to the ground.

7.1.3 EMC Directive Compliance

Electromagnetic compatibility (EMC) describes the ability of electrical and electronic devices to work properly in the electromagnetic environment without introducing electromagnetic interferences that disturb the operation of other local devices or systems. In other words, EMC includes two aspects:

- 1) The electromagnetic interference generated by a device during normal operation cannot exceed a certain limit.
- 2) The device must have sufficient immunity to the electromagnetic interference in the environment.

Abide by the following requirements to make SV630N series servo drives comply with the European EMC directive 2014/30/EU, EN 61800-3 C2, EN 61800-3, and EN 61800-5-2:2017.

- 1) Install the recommended external EMC filter on the servo drive's input end and the shielded cable on the output end. Ensure that the filter is reliably grounded and the output cable shield is

grounded 360 degrees with a cable gland. See [“7.1.5 Selection of EMC Filters”](#) for selection of the EMC filter.

- 2) Install the recommended AC reactor on the input end. See section [“7.1.5 Selection of EMC Filters”](#) for selection of the reactor.
- 3) Use a shielded cable between the servo drive and the motor. See [“3 Wiring”](#) for selection and layout of the cables.
- 4) Install and wire the servo drive according to the recommended wiring method. See [“3 Wiring”](#) for details.
- 5) Install a common mode filter if necessary.

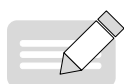

NOTE

- ◆ When applied in the first environment, the servo drive may generate radio interference. In addition to the CE compliance requirements described in this chapter, take measures to prevent the radio interference if necessary.
- ◆ The manufacturer of the system integrated with this drive is responsible for compliance of the system with the European EMC directive and standard EN 61800-3:2004 +A1:2012 according to the system application environment.

7.1.4 Definition of EMC Terms

First environment: Environment that includes domestic premises, and establishments directly connected without intermediate transformers to a low-voltage power supply network which supplies buildings used for domestic purposes

Second environment: Environment that includes all establishments other than those directly connected to a low-voltage power supply network which supplies buildings used for domestic purposes

Category C1 drive: Power drive system (PDS) with rated voltage less than 1000 V, intended for use in the first environment

Category C2 drive: PDS with rated voltage less than 1000 V, which is neither a plug-in device nor a movable device and, when used in the first environment, is intended to be installed and commissioned only by professionals

Category C3 drive: PDS with rated voltage less than 1000 V, intended for use in the second environment and not intended for use in the first environment

Category C4 drive: PDS with rated voltage equal to or above 1000 V, or rated current equal to or above 400 A, or intended for use in complex systems in the second environment

7.1.5 Selection of EMC Filters

■ EMI filter

The following series of filters fulfill the EN 61800-3 C2 emission requirement of CE certification. Connect the filter and the servo drive to the same grounding reference surface to enable reliable grounding of the filter. The cable between the filter and the servo drive must be shielded cable with length less than 30 cm.

- 1) Appearance



Figure 7-2 Schaffner FN3258 series filter



Figure 7-3 Schaffner FN2080 series filter

■ Recommended Model Selection

The recommended Schaffner models are listed in the following table.

Table 7-2 Recommended EMC input filters

Series	Servo Drive Model	Rated Input Current (In)	Filter Model (Manufacturer: Schaffner)
Single-phase 220 V			
Size A	SV630NS1R6I	2.3	FN2090-3-06
	SV630NS2R8I	4	FN2090-4-06
Size B	SV630NS5R5I	7.9	FN2090-8-06
Size C	SV630NS7R6I	5.1	FN 3258-7-44
Size D	SV630NS012I	8	FN 3258-16-44
Three-phase 220 V			
Size C	SV630NS7R6I	5.1	FN 3258-7-44
Size D	SV630NS012I	8	FN 3258-16-44
Three-phase 380 V			
Size C	SV630NT3R5I	2.4	FN 3258-7-44
	SV630NT5R4I	3.6	FN 3258-7-44
Size D	SV630NT8R4I	5.6	FN 3258-7-44
	SV630NT012I	8	FN 3258-16-44
Size E	SV630NT017I	12	FN 3258-16-44
	SV630NT021I	16	FN 3258-16-44
	SV630NT026I	21	FN 3258-30-33

2) Mounting dimensions (FN2080 and FN3258)

Multiple servo drives can be connected to the same external EMI filter if the following conditions are met:

- The single-phase device is connected to a single-phase EMI filter, and the three-phase device is connected to a three-phase EMI filter.
- The total current consumption of the connected devices must be equal to or less than the rated current allowed by the EMI filter.
- Dimensions of Schaffner FN2080 series filters (1-16 A)

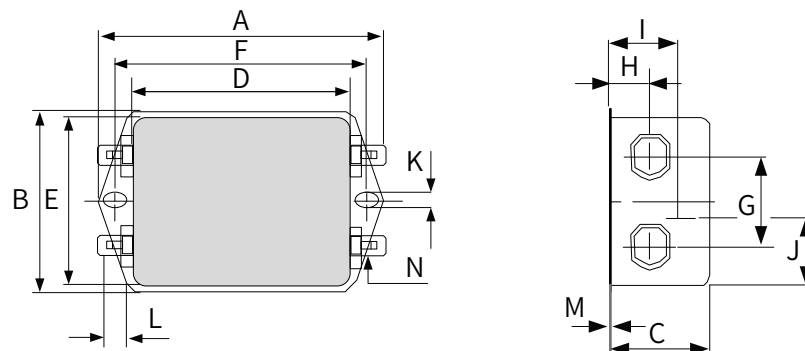

Figure 7-4 Dimensions of FN2080 series filters (1-16 A) (unit: mm)

Table 7-3 Dimensions of FN2080 series filters (1-16 A) (unit: mm)

Rated Current (A)	A	B	C	D	E	F	G	H	I	J	K	L	M	N
1	85	54	30.3	64.8	49.8	75	27	12.3	20.8	19.9	5.3	6.3	0.7	6.3 x 0.8
3	85	54	40.3	64.8	49.8	75	27	12.3	29.8	11.4	5.3	6.3	0.7	6.3 x 0.8
6	113.5±1	57.5±1	45.4±1	94±1	56	103	25	12.4	32.4	15.5	4.4	6	1	6.3 x 0.8
10	156±1	57.5±1	45.4±1	130.5±1	56	143	25	12.4	32.5	15.5	5.3	6	1	6.3 x 0.8
12	156±1	57.5±1	45.4±1	130.5±1	56	143	25	12.4	32.5	15.5	5.3	6	1	6.3 x 0.8
16	119±1	85.5±1	57.6±1	98.5±1	84.5	109	40	15.6	-	42.25	4.4	7.4	1.2	6.3 x 0.8

■ Dimensions of Schaffner FN3258 series filters (7-180 A)

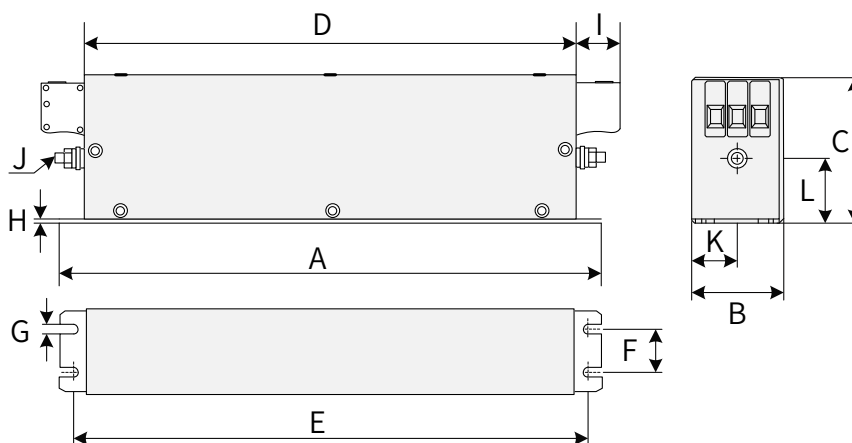

Figure 7-5 Dimensions of FN3258 series filters (7-180 A) (unit: mm)

Table 7-4 Dimensions of FN3258 series filters (7-180 A)

Rated Input Current (A)	A (mm)	B (mm)	C (mm)	D (mm)	E (mm)	F (mm)	G (mm)	H (mm)	I (mm)	J	K (mm)	L (mm)
7	190	40	70	160	180	20	4.5	1	22	M5	20	29.5
16	250	45	70	220	235	25	5.4	1	22	M5	22.5	29.5
30	270	50	85	240	255	30	5.4	1	25	M5	25	39.5
42	310	50	85	280	295	30	5.4	1	25	M6	25	37.5
55	250	85	90	220	235	60	5.4	1	39	M6	42.5	26.5
75	270	80	135	240	255	60	6.5	1.5	39	M6	40	70.5
100	270	90	150	240	255	65	6.5	1.5	45	M10	45	64
130	270	90	150	240	255	65	6.5	1.5	45	M10	45	64
180	380	120	170	350	365	102	6.5	1.5	51	M10	60	47

3) Safety capacitance box and magnetic ring

To filter out part of the interference generated during running, connect a safety capacitance box and wind a magnetic ring around the input/output cable in some applications.

The safety capacitance box must be grounded to the grounding terminal of the servo drive with a grounding cable as short as possible (within 15 cm).

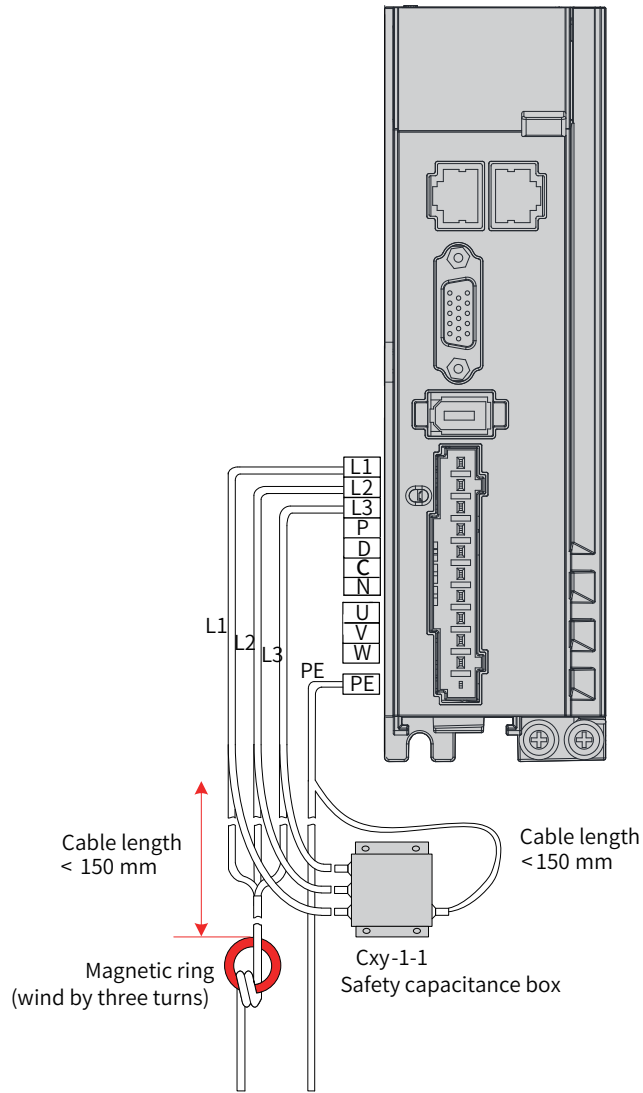

Figure 7-6 Installation of the capacitance box and the magnetic ring

■ Dimension drawing of the safety capacitance box

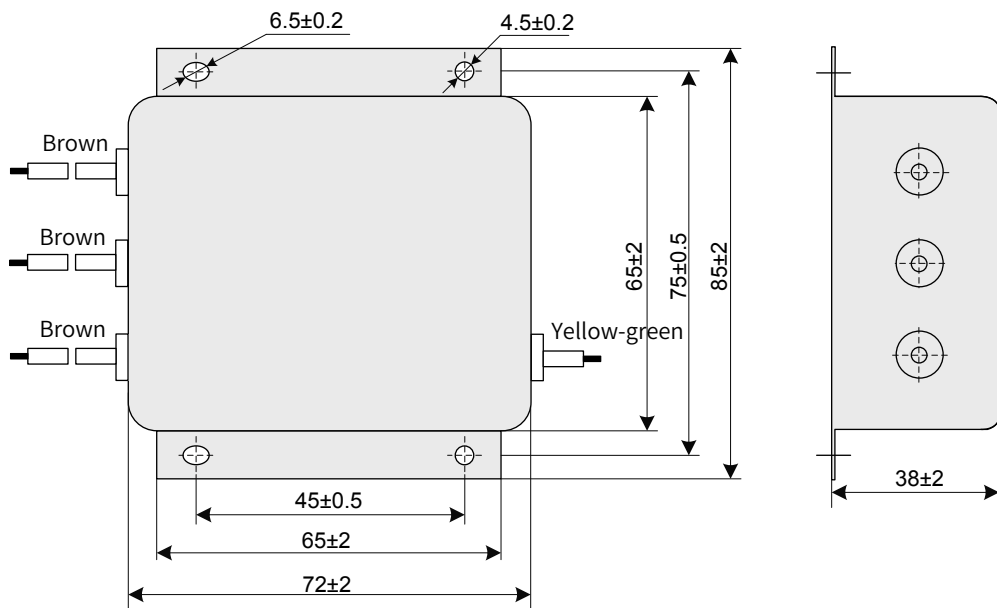

Figure 7-7 Dimensions of the safety capacitance box

Table 7-5 Dimensions of the safety capacitance box

Safety Capacitance Box Model	Code	Dimension (Width x Depth x Height) (mm)	Mounting Dimension (Width x Depth) (mm)
Cxy-1-1	11025018	85 x 72 x 38	45 x 75

■ Selection of the output magnetic ring

To reduce the noise current and the interference to neighboring devices, install the output magnetic ring around the U/V/W power cables (PE excluded) near the servo drive side.

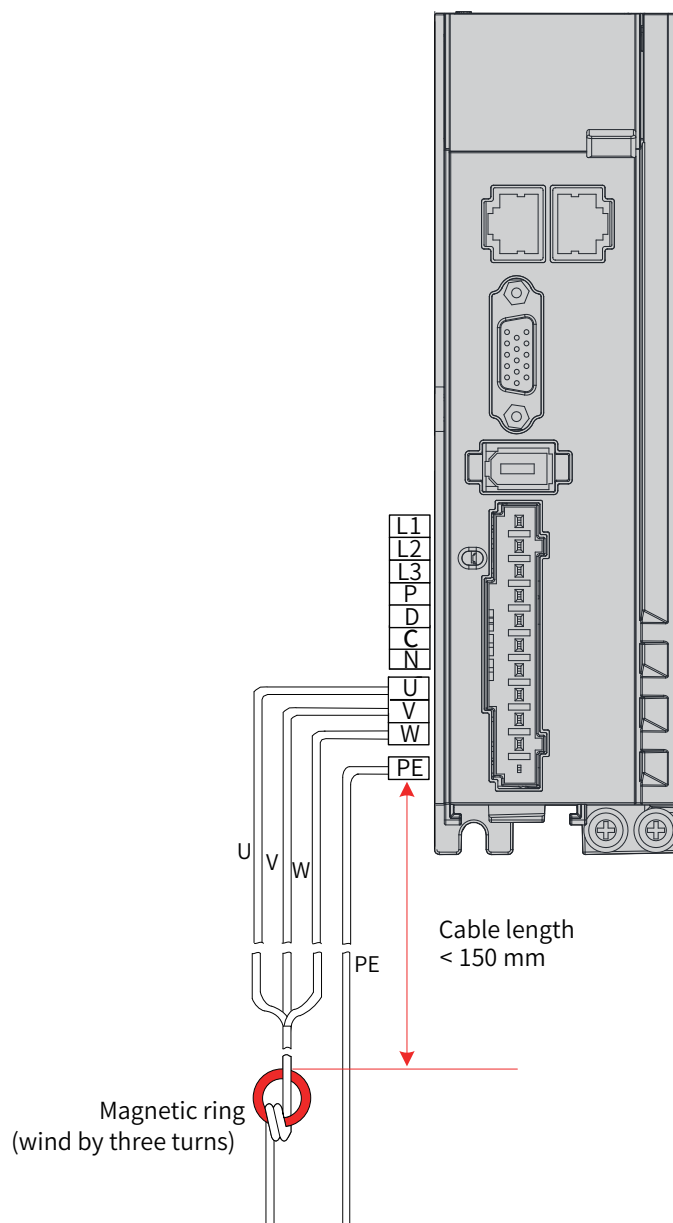

Figure 7-8 Installation of the output magnetic ring (external)



Figure 7-9 Appearance of the output magnetic rings (external)

Table 7-6 Model selection of the output magnetic rings (external)

Magnetic Ring Model	Code	Dimensions (Outer Diameter x Inner Diameter x Thickness) (mm)
CTRC 0930 -1B	11013003	19.5 x 9 x 35
7427122S	11013046	32.8 x 13.5 x 28
DY644020H	11013031	64 x 40 x 20
DY805020H	11013032	80 x 50 x 20
DY1207030H	11013033	120 x 70 x 30

■ AC input reactor

The AC input reactor is an option used to suppress the harmonics in the input current. In applications where strong suppression of harmonics is required, install an external AC input reactor.

7.1.6 Cable Requirements and Routing

■ Requirements on Power Cables

To fulfill the EMC requirements of CE marking, use shielded cables. Shielded cables are classified into three-conductor cables and four-conductor cables. If the conductivity of the cable shield cannot meet the requirement, add a separate PE cable, or use a four-conductor shielded cable, of which one phase conductor is PE cable. The cable shield, which serves to suppress the emission and conduction of the radio frequency interference, must be made of co-axial copper braids with a weaving density larger than 85% to enhance shielding and conductivity performance.

Power cables recommended are shielded cables, as shown in the following figure.

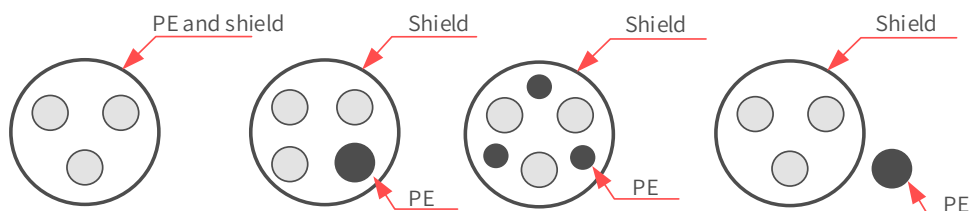

■ Requirements on wiring

- 1) The motor cables and PE shielded cables (twisted) must be as short as possible. For motor cables over 100 meters, install an output filter or a dv/dt reactor.
- 2) It is recommended to adopt shielded cables for the control signals.
- 3) It is recommended to adopt shielded cables for the motor brake.

- 4) The motor cables must be routed away from other cables. The motor cables of several servo drives can be routed in parallel.
- 5) It is recommended that the motor cables, power input cables and control cables be routed in different cable duct. The motor cables and other cables cannot be routed in parallel for a long distance. This is to prevent the electromagnetic interference caused by rapid change of the drive output voltage.
- 6) If the control cable must pass through the power cable, make sure the angle between them is close to 90 degrees. Other cables cannot pass through the servo drive.
- 7) Power input and output cables and signal cables (such as control cables) of the servo drive should, if possible, be laid upright rather than in parallel.
- 8) Cable ducts must be in good connection and well grounded. Aluminum cable ducts can be used to improve equal potential.
- 9) The grounding plane of different equal potential must be connected properly using cables with a cross sectional area of more than 16 mm².
- 10) The filter, the servo drive and the motor must be properly connected to the electrical system, with the conductive metal kept in full contact.

■ The recommended wiring diagram is shown below.

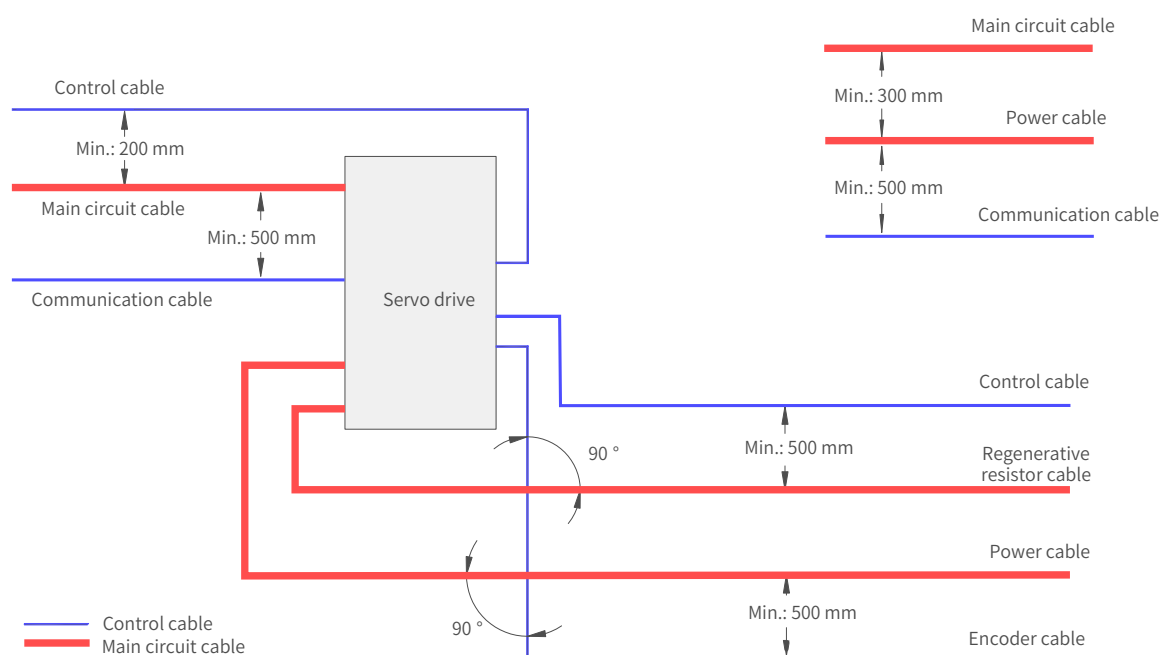

7.1.7 Solutions to Leakage Current

The servo drive outputs high-speed pulse voltage, which may generate high-frequency leakage current. It is recommended to use a residual current device (RCD) with tripping current not lower than 100 mA. If multiple servo drives share the same RCD, the tripping current of this RCD must be equal to or larger than 300 mA.

Factors that affect the leakage current are listed as follows:

- Distributed capacitance of the motor
- Carrier frequency
- Type and length of the motor cables.

- EMI filter

When the leakage current generated by the servo drive causes the RCD to trip, take the following measures:

- Increase the rated tripping current of the RCD.
- Replace the original RCD with a time-delay type-B RCD.
- Reduce the carrier frequency.
- Shorten the length of the drive output cables.
- Wind the magnetic ring around the power cables (PE cable excluded). Recommended RCD brands are Chint and Schneider.

7.1.8 Solutions to Common EMC Problems

The servo drive generates strong interferences. Although EMC measures are taken, interference may still exist due to improper wiring or grounding during use. When the servo drive interferes with other devices, adopt the following solutions.

Table 7-7 Solutions to common EMC interference problems

Interference Type	Solution
RCD tripping	<ul style="list-style-type: none"> ◆ Reduce the carrier frequency without compromising the performance. ◆ Shorten the servo drive cable length. ◆ Wind the ferrite core around the power cables (PE cable excluded). ◆ For tripping at the moment of power-on, disconnect the capacitor that carries larger capacity (disconnect the grounding end of the external or internal filter and the grounding end of the grounding Y capacitor of the input terminal). ◆ For tripping during running or enabling, take leakage current suppression measures, such as installing a leakage current filter or a safety capacitor, and/or winding a magnetic ring.
Interference generated during running	<ul style="list-style-type: none"> ◆ Connect the motor housing to the PE terminal of the servo drive. ◆ Connect the PE terminal of the servo drive to the PE terminal of the mains power supply. ◆ Route the power cables (main circuit cables, power cables, and regenerative resistor cables), control cables, and signal cables through different routes. ◆ Wind the ferrite core around the power cables (PE cable excluded). ◆ Install a capacitor to the interfered signal port or wind the ferrite core around this port. ◆ Install a matching resistor between the communication cable source and the load end. ◆ Add an auxiliary reference ground wire if the differential cable pair are used for communication. ◆ Adopt shielded cables as communication cables ◆ Apply additional common-ground connection between devices and cabinets.

7.1.9 UL Certification



Figure 7-10 UL/cUL mark

The UL/cUL mark is commonly applied to products in the United States and Canada. It indicates that UL has performed product tests and evaluations, and determined that their stringent standards for product safety have been met. For a product to receive UL certification, the main components inside that product must also be UL certified.

This series of servo drives have been tested in accordance with UL standard 61800-5-1 and CSA C22.2 No. 274-17 and comply with UL/cUL standards. Abide by the following requirements to enable machines and devices integrated with this servo drive to comply with UL/cUL standards.

- Installation location

Install the servo drive in a place with pollution degree 1 or 2 (UL standard).

- Ambient temperature

Run the servo drive in an ambient temperature not higher than 50° C.

- Wiring example

See [“3 Wiring”](#) or the wiring diagram that complies with the Low Voltage Directive.

- Wiring of main circuit terminals

To meet UL standard, use UL-compliant crimping terminals to crimp the cables on main circuit terminals with the tools recommended by the terminal manufacturer for crimping. Use crimping terminals with insulated cladding or insulated sleeves.

Adopt UL-compliant insulated copper cables as main circuit cables, and the continuous maximum allowable temperature of such cables is 75° C.

Select the cable dimension and tightening torque according to [“3 Wiring”](#) during wiring.

(Note: “” indicates the grounding terminal defined in IEC/EN60417-5019)

- Fuse on the input side (primary side)

To prevent accidents caused by short circuit, connect a fuse that complies with UL standards on the input side. See [“6 Troubleshooting”](#) for fuse selection.

See the specifications and model selection of the servo drive for the input and output current of the servo drive.

See [“6 Troubleshooting”](#) for fuse model recommendations.



NOTE

- ◆ When the fuse burns or the wiring breaker trips, do not switch on the power supply or operate the machine immediately. Check the wiring and the models of peripherals to identify the cause. If the cause cannot be identified, contact Inovance. Do not switch on the power supply or operate the machine without permission before identifying the cause.
- ◆ Each input cable of the servo drive must be connected to a fuse. When a fuse burns, replace all the fuses.

■ Short-circuit withstand capacity

This series of servo drives adopt the Bussmann FWH series fuses, which can be used in a main circuit of 480 V (400 V class) and below, with short-circuit current less than 100,000 A.

7.2 List of Object Groups

Description of Object Groups

Parameter access address: Index + subindex, both are hexadecimal data.

The CiA402 protocol establishes the following constraints on the parameter address.

Index (Hex)	Description
0000-0FFF	Data type description
1000-1FFF	CoE communication object
2000-5FFF	Manufacturer-defined object
6000-9FFF	Profile object
A000-FFFF	Reserved

Object Group 1000h

Index (hex)	Sub-index (hex)	Name	Accessibility	PDO Mapping	Data Type	Unit	Data Range	Default
1000	00	Device type	RO	NO	Uint32	-	-	0x00020192
1008	00	Manufacturer device name	RO	NO	-	-	-	SV630N-ECAT
1009	00	Manufacturer hardware version	RO	NO	-	-	-	Determined by the hardware version
100A	00	Manufacturer software version	RO	NO	-	-	-	Determined by the software version
1018	ID object							
	00	Highest sub-index No. included in the ID object	RO	NO	Uint8	-	-	0x04
	01	Vendor ID	RO	NO	Uint32	-	-	0x00100000
	02	Product code	RO	NO	Uint32	-	-	0x000C010D
	03	Revision number	RO	NO	Uint32	-	-	0x00010001
	04	Serial No.	RO	NO	Uint32	-	-	0x00000000
1C00	Manufacturer software version							
	00	Number of Sync Manager channels	RO	NO	Uint8	-	-	0x04
	01	Communication type SM0	RO	NO	Uint8	-	-	0x01
	02	Communication type SM1	RO	NO	Uint8	-	-	0x02
	03	Communication type SM2	RO	NO	Uint8	-	-	0x03
	04	Communication type SM3	RO	NO	Uint8	-	-	0x04

Index (hex)	Sub-index (hex)	Name	Accessibility	PDO Mapping	Data Type	Unit	Data Range	Default
1600	RPDO mapping object in group 1600							
	00	Number of mapping objects in group 1600	RW	NO	Uint8	-	0-0x0A	0x03
	01	1st mapping object	RW	NO	Uint32	-	0-0xFFFFFFFF	0x60400010
	02	2nd mapping object	RW	NO	Uint32	-	0-0xFFFFFFFF	0x60600008
	03	3rd mapping object	RW	NO	Uint32	-	0-0xFFFFFFFF	0x60B80010
	04	4th mapping object	RW	NO	Uint32	-	0-0xFFFFFFFF	-
	05	5th mapping object	RW	NO	Uint32	-	0-0xFFFFFFFF	-
	06	6th mapping object	RW	NO	Uint32	-	0-0xFFFFFFFF	-
	07	7th mapping object	RW	NO	Uint32	-	0-0xFFFFFFFF	-
	08	8th mapping object	RW	NO	Uint32	-	0-0xFFFFFFFF	-
	09	9th mapping object	RW	NO	Uint32	-	0-0xFFFFFFFF	-
0A	10th mapping object	RW	NO	Uint32	-	0-0xFFFFFFFF	-	
1701	RPDO mapping objects in group 1701							
	00	Number of mapping objects in group 1701	RO	NO	Uint8	-	-	0x04
	01	1st mapping object	RO	NO	Uint32	-	-	0x60400010
	02	2nd mapping object	RO	NO	Uint32	-	-	0x607A0020
	03	3rd mapping object	RO	NO	Uint32	-	-	0x60B80010
04	4th mapping object	RO	NO	Uint32	-	-	0x60FE0120	
1702	RPDO mapping objects in group 1702							
	00	Number of mapping objects in group 1702	RO	NO	Uint8	-	-	0x07
	01	1st mapping object	RO	NO	Uint32	-	-	0x60400010
	02	2nd mapping object	RO	NO	Uint32	-	-	0x607A0020
	03	3rd mapping object	RO	NO	Uint32	-	-	0x60FF0020
	04	4th mapping object	RO	NO	Uint32	-	-	0x60710010
	05	5th mapping object	RO	NO	Uint32	-	-	0x60600008
	06	6th mapping object	RO	NO	Uint32	-	-	0x60B80010
07	7th mapping object	RO	NO	Uint32	-	-	0x607F0020	
1703	RPDO mapping objects in group 1703							
	00	Number of mapping objects in group 1703	RO	NO	Uint8	-	-	0x07
	01	1st mapping object	RO	NO	Uint32	-	-	0x60400010
	02	2nd mapping object	RO	NO	Uint32	-	-	0x607A0020
	03	3rd mapping object	RO	NO	Uint32	-	-	0x60FF0020
	04	4th mapping object	RO	NO	Uint32	-	-	0x60600008
	05	5th mapping object	RO	NO	Uint32	-	-	0x60B80010
	06	6th mapping object	RO	NO	Uint32	-	-	0x60E00010
07	7th mapping object	RO	NO	Uint32	-	-	0x60E10010	

Index (hex)	Sub-index (hex)	Name	Accessibility	PDO Mapping	Data Type	Unit	Data Range	Default
1704	RPDO mapping objects in group 1704							
	00	Number of mapping objects in group 1704	RO	NO	Uint8	-	-	0x09
	01	1st mapping object	RO	NO	Uint32	-	-	0x60400010
	02	2nd mapping object	RO	NO	Uint32	-	-	0x607A0020
	03	3rd mapping object	RO	NO	Uint32	-	-	0x60FF0020
	04	4th mapping object	RO	NO	Uint32	-	-	0x60710010
	05	5th mapping object	RO	NO	Uint32	-	-	0x60600008
	06	6th mapping object	RO	NO	Uint32	-	-	0x60B80010
	07	7th mapping object	RO	NO	Uint32	-	-	0x607F0020
	08	8th mapping object	RO	NO	Uint32	-	-	0x60E00010
09	9th mapping object	RO	NO	Uint32	-	-	0x60E10010	
1705	RPDO mapping objects in group 1705							
	00	Number of mapping objects in group 1705	RW	NO	Uint8	-	-	0x08
	01	1st mapping object	RW	NO	Uint32	-	-	0x60400010
	02	2nd mapping object	RW	NO	Uint32	-	-	0x607A0020
	03	3rd mapping object	RW	NO	Uint32	-	-	0x60FF0020
	04	4th mapping object	RW	NO	Uint32	-	-	0x60600008
	05	5th mapping object	RW	NO	Uint32	-	-	0x60B80010
	06	6th mapping object	RW	NO	Uint32	-	-	0x60E00010
	07	7th mapping object	RW	NO	Uint32	-	-	0x60E10010
08	8th mapping object	RW	NO	Uint32	-	-	0x60B20010	
1A00	Mapping objects in group 1A00							
	00	Number of mapping objects in group 1A00	RW	NO	Uint8	-	0-0x0A	0x07
	01	1st mapping object	RW	NO	Uint32	-	0-0xFFFFFFFF	0x60410010
	02	2nd mapping object	RW	NO	Uint32	-	0-0xFFFFFFFF	0x60640020
	03	3rd mapping object	RW	NO	Uint32	-	0-0xFFFFFFFF	0x60B90010
	04	4th mapping object	RW	NO	Uint32	-	0-0xFFFFFFFF	0x60BA0020
	05	5th mapping object	RW	NO	Uint32	-	0-0xFFFFFFFF	0x60BC0020
	06	6th mapping object	RW	NO	Uint32	-	0-0xFFFFFFFF	0x603F0010
	07	7th mapping object	RW	NO	Uint32	-	0-0xFFFFFFFF	0x60FD0010
	08	8th mapping object	RW	NO	Uint32	-	0-0xFFFFFFFF	-
09	9th mapping object	RW	NO	Uint32	-	0-0xFFFFFFFF	-	
0A	10th mapping object	RW	NO	Uint32	-	0-0xFFFFFFFF	-	
1B01	Mapping objects in group 1B01							
	00	Number of mapping objects in group 1B01	RO	NO	Uint8	-	-	0x09
	01	1st mapping object	RO	NO	Uint32	-	-	0x603F0010
	02	2nd mapping object	RO	NO	Uint32	-	-	0x60410010
	03	3rd mapping object	RO	NO	Uint32	-	-	0x60640020
	04	4th mapping object	RO	NO	Uint32	-	-	0x60770010
	05	5th mapping object	RO	NO	Uint32	-	-	0x60F40020
	06	6th mapping object	RO	NO	Uint32	-	-	0x60B90010
	07	7th mapping object	RO	NO	Uint32	-	-	0x60BA0020
	08	8th mapping object	RO	NO	Uint32	-	-	0x60BC0020
09	9th mapping object	RO	NO	Uint32	-	-	0x60FD0010	

Index (hex)	Sub-index (hex)	Name	Accessibility	PDO Mapping	Data Type	Unit	Data Range	Default
1B02	Mapping objects in group 1B02							
	00	Number of mapping objects in group 1B02	RO	NO	Uint8	-	-	0x09
	01	1st mapping object	RO	NO	Uint32	-	-	0x603F0010
	02	2nd mapping object	RO	NO	Uint32	-	-	0x60410010
	03	3rd mapping object	RO	NO	Uint32	-	-	0x60640020
	04	4th mapping object	RO	NO	Uint32	-	-	0x60770010
	05	5th mapping object	RO	NO	Uint32	-	-	0x60610008
	06	6th mapping object	RO	NO	Uint32	-	-	0x60B90010
	07	7th mapping object	RO	NO	Uint32	-	-	0x60BA0020
	08	8th mapping object	RO	NO	Uint32	-	-	0x60BC0020
1B03	Mapping objects in group 1B03							
	00	Number of mapping objects in group 1B03	RO	NO	Uint8	-	-	0x0A
	01	1st mapping object	RO	NO	Uint32	-	-	0x603F0010
	02	2nd mapping object	RO	NO	Uint32	-	-	0x60410010
	03	3rd mapping object	RO	NO	Uint32	-	-	0x60640020
	04	4th mapping object	RO	NO	Uint32	-	-	0x60770010
	05	5th mapping object	RO	NO	Uint32	-	-	0x60F40020
	06	6th mapping object	RO	NO	Uint32	-	-	0x60610008
	07	7th mapping object	RO	NO	Uint32	-	-	0x60B90010
	08	8th mapping object	RO	NO	Uint32	-	-	0x60BA0020
1B04	Mapping objects in group 1B04							
	00	Number of mapping objects in group 1B04	RO	NO	Uint8	-	-	0x0A
	01	1st mapping object	RO	NO	Uint32	-	-	0x603F0010
	02	2nd mapping object	RO	NO	Uint32	-	-	0x60410010
	03	3rd mapping object	RO	NO	Uint32	-	-	0x60640020
	04	4th mapping object	RO	NO	Uint32	-	-	0x60770010
	05	5th mapping object	RO	NO	Uint32	-	-	0x60610008
	06	6th mapping object	RO	NO	Uint32	-	-	0x60F40020
	07	7th mapping object	RO	NO	Uint32	-	-	0x60B90010
	08	8th mapping object	RO	NO	Uint32	-	-	0x60BA0020
1C12	Sync Manager 2_RPDO assignment							
	00	Number of assigned RPDOs	RW	NO	Uint8	-	0-0x01	0x01
	01	1st PDO mapping object index of assigned RPDO	RW	YES	Uint16	-	0-0xFFFF	0x1701

Index (hex)	Sub-index (hex)	Name	Accessibility	PDO Mapping	Data Type	Unit	Data Range	Default
Sync Manager 2_TPDO assignment								
1C13	00	Number of assigned TPDOs	RW	NO	Uint8	-	0-0x1	0x01
	01	1st PDO mapping object index of assigned TPDO	RW	YES	Uint16	-	0-0xFFFF	0x1B01
Sync Manager 2 Synchronization output								
1C32	00	Number of synchronization parameters	RO	NO	Uint8	-	-	0x20
	01	Synchronization type	RO	NO	Uint16	-	-	0x0002
	02	Cycle time	RO	NO	Uint32	ns	-	0
	04	Synchronization types supported	RO	NO	Uint16	-	-	0x0004
	05	Minimum cycle time	RO	NO	Uint32	ns	-	0x0003D090
	06	Calculation and copy time	RO	NO	Uint32	ns	-	-
	09	Delay time	RO	NO	Uint32	ns	-	-
	20	Synchronization error	RO	NO	BOOL	-	-	-
Sync Manager 2 Synchronization input								
1C33	00	Number of synchronization parameters	RO	NO	Uint8	-	-	0x20
	01	Synchronization type	RO	NO	Uint16	-	-	0x0002
	02	Cycle Time	RO	NO	Uint32	ns	-	0
	04	Synchronization types supported	RO	NO	Uint16	-	-	0x0004
	05	Minimum cycle time	RO	NO	Uint32	ns	-	0x0003D090
	06	Calculation and copy time	RO	NO	Uint32	ns	-	-
	09	Delay time	RO	NO	Uint32	ns	-	-
	20	Synchronization error	RO	NO	BOOL	-	-	-

Object Group 2000h

Parameter Group			Name	Option Description	Value Range	Default	Min. Unit	Width	Setting Condition	Effective Time
Hexadecimal	Decimal	Para. No.								
Group	Index Code	Para. No.								
2000h/H00 Servo motor parameters										
2000	01h	H00-00	Motor code	-	0-65535	14101	1	16 bits	At stop	Next power-on
	03h	H00-02	Customized software version	-	0-0xFFFFFFFF	0	1	32 bits	-	-
	05h	H00-04	Encoder version	-	0-65535	0	0.1	16 bits	-	-
	06h	H00-05	Serial-type motor code	-	0-65535	0	1	16 bits	-	-
	07h	H00-06	FPGA customized No.	-	0-65535	0	1	16 bits	-	-
	08h	H00-07	STO version	-	0-65535	0	1	16 bits	-	-
	09h	H00-08	Serial encoder type	-	0-65535	0	1	16 bits	At stop	Next power-on
2001h/H01: Servo drive parameters										
2001	01h	H01-00	MCU software version	-	0-6553.5	0	1	16 bits	-	-
	02h	H01-01	FPGA software version	-	0-6553.5	0	1	16 bits	-	-
	0Bh	H01-10	Servo drive series number	2: 1R6 3: S2R8 5: S5R5 60005: S6R6 6: S7R6 7: S012 10001: T3R5 10002: T5R4 10003: T8R4 10004: T012 10005: T017 10006: T021 10007: T026	0-65535	3	1	16 bits	At stop	Next power-on
	0Ch	H01-11	Voltage class of the drive unit	-	0-65535	220	1 V	16 bits	-	-
	0Dh	H01-12	Rated power of the servo drive	-	0-10737418.24	0.4	1 kW	32 bits	-	-
	0Fh	H01-14	Max. output power of the servo drive	-	0-10737418.24	0.4	1 kW	32 bits	-	-
	11h	H01-16	Rated output current of the servo drive	-	0-10737418.24	2.8	1 A	32 bits	-	-
	13h	H01-18	Max. output current of the servo drive	-	0-10737418.24	10.1	1 A	32 bits	-	-
	29h	H01-40	DC bus overvoltage protection threshold	-	0-2000	420	1 V	16 bits	-	-
2002h/H02 Basic control parameters										
2002	01h	H02-00	Control mode	0: Speed control mode 1: Position control mode 2: Torque control mode 9: EtherCAT mode	0-9	9	1	16 bits	At stop	Immediately

7 Appendix

Parameter Group			Name	Option Description	Value Range	Default	Min. Unit	Width	Setting Condition	Effective Time
Hexadecimal		Decimal								
Group	Index Code	Para. No.								
2002	02h	H02-01	Absolute system selection	0: Incremental mode 1: Absolute position linear mode 2: Absolute position rotation mode 3: Absolute position linear mode, no encoder overflow alarm 4: Absolute position single-turn mode	0-4	0	1	16 bits	At stop	Next power-on
	03h	H02-02	Rotation direction	0: CCW direction as the forward direction 1: CW direction as the forward direction	0-1	0	1	16 bits	At stop	Next power-on
	06h	H02-05	Stop mode at S-ON OFF	-3: Stop at zero speed, keeping DB state -2: Ramp to stop as defined by 6084h/609Ah, keeping DB state -1: DB stop, keeping DB state 0: Coast to stop, keeping de-energized state 1: Ramp to stop as defined by 6084h/609Ah, keeping de-energized state	-3 to +1	0	1	16 bits	At stop	Immediately
	07h	H02-06	Stop mode at No. 2 fault	-5: Stop at zero speed, keeping DB state -4: Stop at emergency torque, keeping DB state -3: Ramp to stop as defined by 6084h, keeping DB state -2: Ramp to stop as defined by 6084h/609Ah, keeping DB state -1: DB stop, keeping DB state 0: Coast to stop, keeping de-energized state 1: Ramp to stop as defined by 6084h/609Ah, keeping de-energized state 2: Ramp to stop as defined by 6084h, keeping de-energized state 3: Stop at emergency torque, keeping de-energized state	-5 to +3	2	1	16 bits	At stop	Immediately

Parameter Group			Name	Option Description	Value Range	Default	Min. Unit	Width	Setting Condition	Effective Time
Hexadecimal	Decimal	Para. No.								
Group	Index Code	Para. No.								
2002	08h	H02-07	Stop mode upon overtravel	0: Coast to stop, keeping de-energized state 1: Stop at zero speed, keeping position lock state 2: Stop at zero speed, keeping de-energized state 3: Ramp to stop as defined by 6084h/609Ah, keeping de-energized state 4: Ramp to stop as defined by 6084h/609Ah, keeping position lock state 5: DB stop, keeping de-energized state 6: DB stop, keeping DB state 7: Not responding to overtravel, displaying the alarm only	0-7	1	1	16 bits	At stop	Immediately
	09h	H02-08	Stop mode at No. 1 fault	0: Coast to stop, keeping de-energized state 1: DB Stop, keeping de-energized state 2: DB Stop, keeping DB state	0-2	2	1	16 bits	At stop	Immediately
	0Ah	H02-09	Delay from brake output ON to command received	-	0-500	250	1 ms	16 bits	During running	Immediately
	0Bh	H02-10	Delay from brake output OFF to motor de-energized	-	50-1000	150	1 ms	16 bits	During running	Immediately
	0Ch	H02-11	Motor speed threshold at brake output OFF in the rotation status	-	20-3000	30	1 RPM	16 bits	During running	Immediately

7 Appendix

Parameter Group			Name	Option Description	Value Range	Default	Min. Unit	Width	Setting Condition	Effective Time
Hexadecimal	Decimal	Para. No.								
Group	Index Code	Para. No.								
2002	0Dh	H02-12	Delay from S-ON OFF to brake output OFF in the rotation state	-	1-1000	500	1 ms	16 bits	During running	Immediately
	10h	H02-15	Warning display on keypad	0: Output warning information immediately 1: Not output warning information	0-1	0	1	16 bits	During running	Immediately
	15h	H02-20	DB relay coil ON delay	-	30-30000	30	1 ms	16 bits	During running	Immediately
	16h	H02-21	Permissible min. resistance of regenerative resistor	-	1-1000	40	1 Ω	16 bits	-	-
	17h	H02-22	Power of built-in regenerative resistor	-	0-65535	0	1 W	16 bits	-	-
	18h	H02-23	Resistance of built-in regenerative resistor	-	0-65535	0	1 Ω	16 bits	-	-
	19h	H02-24	Resistor heat dissipation coefficient	-	10-100	30	1%	16 bits	During running	Immediately
	1Ah	H02-25	Regenerative resistor type	0: Built-in 1: External, naturally ventilated 2: External, forced air cooling 3: No regenerative resistor needed	0-3	3	1	16 bits	During running	Immediately
	1Bh	H02-26	Power of external regenerative resistor	-	1-65535	40	1 kW	16 bits	During running	Immediately
	1Ch	H02-27	Resistance of external regenerative resistor	-	15-1000	50	1 Ω	16 bits	During running	Immediately
	1Fh	H02-30	User password	-	0-65535	0	1	16 bits	During running	Immediately
	20h	H02-31	System parameter initialization	0: No operation 1: Restore default settings 2: Clear fault records	0-2	0	1	16 bits	At stop	Immediately
	21h	H02-32	Group H0B parameter selection	-	0-99	50	1	16 bits	During running	Immediately
	24h	H02-35	Keypad data refresh rate	-	0-20	0	1 Hz	16 bits	During running	Immediately
2Ah	H02-41	Factory password	-	0-65535	0	1	16 bits	During running	Immediately	

Parameter Group			Name	Option Description	Value Range	Default	Min. Unit	Width	Setting Condition	Effective Time
Hexadecimal	Decimal	Para. No.								
Group	Index Code	Para. No.	2003h/H03 Terminal input parameters							
2003	03h	H03-02	DI1 function selection	0: No definition 1: S-ON 2: Fault reset 14: Positive limit switch 15: Negative limit switch 31: Home switch 34: Emergency stop 38: Touch probe 1 39: Touch probe 2	0-40	14	1	16 bits	During running	Immediately
	04h	H03-03	DI1 logic selection	0: Normally open 1: Normally closed	0-1	0	1	16 bits	During running	Immediately
	05h	H03-04	DI2 function selection	0-39 See the description of H03-02 for details.	0-40	15	1	16 bits	During running	Immediately
	06h	H03-05	DI2 logic selection	0-1 See the description of H03-03 for details.	0-1	0	1	16 bits	During running	Immediately
	07h	H03-06	DI3 function selection	0-39 See the description of H03-02 for details.	0-40	31	1	16 bits	During running	Immediately
	08h	H03-07	DI3 logic selection	0-1 See the description of H03-03 for details.	0-1	0	1	16 bits	During running	Immediately
	09h	H03-08	DI4 function selection	0-39 See the description of H03-02 for details.	0-40	39	1	16 bits	During running	Immediately
	0Ah	H03-09	DI4 logic selection	0-1 See the description of H03-03 for details.	0-1	0	1	16 bits	During running	Immediately
	0Bh	H03-10	DI5 function selection	0-39 See the description of H03-02 for details.	0-40	38	1	16 bits	During running	Immediately
	0Ch	H03-11	DI5 logic selection	0-1 See the description of H03-03 for details.	0-1	0	1	16 bits	During running	Immediately
	3Dh	H03-60	DI1 filter time	-	0-500	0.5	1 ms	16 bits	During running	Immediately
	3Eh	H03-61	DI2 filter time	-	0-500	0.5	1 ms	16 bits	During running	Immediately
	3Fh	H03-62	DI3 filter time	-	0-500	0.5	1 ms	16 bits	During running	Immediately
	40h	H03-63	DI4 filter time	-	0-500	0.5	1 ms	16 bits	During running	Immediately
	41h	H03-64	DI5 filter time	-	0-500	0.5	1 ms	16 bits	During running	Immediately

7 Appendix

Parameter Group			Name	Option Description	Value Range	Default	Min. Unit	Width	Setting Condition	Effective Time
Hexadecimal	Decimal	Para. No.								
Group	Index Code	Para. No.	2004h/H04 Terminal Output Parameters							
2004	01h	H04-00	DO1 function selection	0: No definition 1: Servo ready 2: Motor rotating 9: Brake output 10: Warning 11: Fault 25: Comparison output 32: STO EDM	0-32	1	1	16 bits	During running	Immediately
	02h	H04-01	DO1 logic selection	0: Normally open 1: Normally closed	0-1	0	1	16 bits	During running	Immediately
	03h	H04-02	DO2 function selection	0-32 See the description of H04-00 for details.	0-32	11	1	16 bits	During running	Immediately
	04h	H04-03	DO2 logic selection	0-1 See the description of H04-01 for details.	0-1	0	1	16 bits	During running	Immediately
	05h	H04-04	DO3 function selection	0-32 See the description of H04-00 for details.	0-32	9	1	16 bits	During running	Immediately
	06h	H04-05	DO3 logic selection	0-1 See the description of H04-01 for details.	0-1	0	1	16 bits	During running	Immediately
	18h	H04-23	EtherCAT forced DO offline output logic	0: Status of DO1 to DO3 unchanged in the non-OP status 1: No output in DO1 and status of others unchanged in the non-OP status 2: No output in DO2 and status of others unchanged in the non-OP status 3: No output in DO1 or DO2 and status of others unchanged in the non-OP status 4: No output in DO3, status of others unchanged in the non-OP status 5: No output in DO1 or DO3, status of others unchanged in the non-OP status 6: No output in DO2 or DO3 and status of others unchanged in the non-OP status 7: No output in DO1, DO2, or DO3.	0-7	0	1	16 bits	During running	Immediately

Parameter Group			Name	Option Description	Value Range	Default	Min. Unit	Width	Setting Condition	Effective Time
Hexadecimal	Decimal	Para. No.								
Group	Index Code	Para. No.	2005h/H05 Position control parameters							
2005	05h	H05-04	First-order low-pass filter time constant	-	0-6553.5	0	1 ms	16 bits	At stop	Immediately
	06h	H05-05	Average filter time constant 1	-	0-1000	0	1 ms	16 bits	At stop	Immediately
	07h	H05-06	Average filter time constant 2	-	0-128	0	1 ms	16 bits	At stop	Immediately
	08h	H05-07	Numerator of electronic gear ratio	-	0-4294967295	1	1	32 bits	During running	Immediately
	0Ah	H05-09	Denominator of electronic gear ratio	-	0-4294967295	1	1	32 bits	During running	Immediately
	14h	H05-19	Speed feedforward control selection	0: No speed feedforward 1: Internal speed feedforward 2: 60B1 as speed feedforward 3: Zero phase control	0-3	1	1	16 bits	At stop	Immediately
	15h	H05-20	Condition for outputting positioning completed signal	0: Position deviation = Filtered position reference - Position feedback	0-3	0	1	16 bits	At stop	Immediately
	24h	H05-35	Duration limit of homing	-	0-6553.5	5000	1s	16 bits	During running	Immediately
	2Fh	H05-46	Position offset in absolute position linear mode (low 32 bits)	-	-2147483648 to +2147483647	0	1	32 bits	During running	Immediately
	31h	H05-48	Position offset in absolute position linear mode (high 32 bits)	-	-2147483648 to +2147483647	0	1	32 bits	During running	Immediately
	33h	H05-50	Numerator of the mechanical gear ratio in absolute position rotation mode	-	1-65535	1	1	16 bits	At stop	Immediately
34h	H05-51	Denominator of mechanical gear ratio in absolute position rotation mode	-	1-65535	1	1	16 bits	At stop	Immediately	
35h	H05-52	Pulses per revolution of the load in absolute position rotation mode (low 32 bits)	-	0-4294967295	0	1p	32 bits	At stop	Immediately	
2005	37h	H05-54	Pulses per revolution of the load in absolute position rotation mode (high 32 bits)	-	0-4294967295	0	1p	32 bits	At stop	Immediately

7 Appendix

Parameter Group			Name	Option Description	Value Range	Default	Min. Unit	Width	Setting Condition	Effective Time
Hexadecimal	Decimal	Para. No.								
Group	Index Code									
2006h/H06 Speed control parameters										
2006	04h	H06-03	Speed reference	-	-6000 to +6000	200	1 RPM	16 bits	During running	Immediately
	06h	H06-05	Acceleration ramp time of speed reference	-	0-65535	0	1 RPM	16 bits	During running	Immediately
	07h	H06-06	Deceleration ramp time of speed reference	-	0-65535	0	1 RPM	16 bits	During running	Immediately
	09h	H06-08	Forward speed limit	-	0-6000	6000	1 RPM	16 bits	During running	Immediately
	0Ah	H06-09	Reverse speed limit	-	0-6000	6000	1 RPM	16 bits	During running	Immediately
	0Bh	H06-10	Deceleration unit under emergency stop	0: x 1 1: x 10 2: x 100	0-2	0	1	16 bits	At stop	Immediately
	0Ch	H06-11	Torque feedforward control selection	0: No torque feedforward 1: Internal torque feedforward 2: 60B2 as external torque feedforward	0-2	1	1	16 bits	During running	Immediately
	0Dh	H06-12	Jog speed acceleration ramp time	-	0-65535	10	1 ms	16 bits	During running	Immediately
	0Eh	H06-13	Speed feedforward smoothing filter	-	0-2000	0	1	16 bits	During running	Immediately
	11h	H06-16	Motor speed threshold	-	0-1000	20	1 RPM	16 bits	During running	Immediately
	17h	H06-22	Enable	0: No 1: Yes	0-1	1	1	16 bits	During running	Immediately
	17h	H06-22	Study	0: No 1: Yes	0-1	1	1	16 bits	During running	Immediately
	1Dh	H06-28	Spline torque compensation selection	0: Disable 1: Enable	0-1	1	1	16 bits	During running	Immediately
2007h/H07 Torque control parameters										
2007	04h	H07-03	Torque reference value set through keypad	-	-400 to +400	0	1%	16 bits	During running	Immediately
	06h	H07-05	Torque reference filter time constant 1	-	0-30	0.2	1 ms	16 bits	During running	Immediately
	07h	H07-06	Torque reference filter time constant 2	-	0-30	0.27	1 ms	16 bits	During running	Immediately
	0Ah	H07-09	Forward internal torque limit	-	0-400	350	1%	16 bits	During running	Immediately
	0Bh	H07-10	Reverse internal torque limit	-	0-400	350	1%	16 bits	During running	Immediately
	10h	H07-15	Emergency stop torque	-	0-400	100	1%	16 bits	During running	Immediately

Parameter Group			Name	Option Description	Value Range	Default	Min. Unit	Width	Setting Condition	Effective Time
Hexadecimal	Decimal	Para. No.								
Group	Index Code	Para. No.								
2007	14h	H07-19	Forward internal speed limit in torque control	-	0-6000	3000	1 RPM	16 bits	During running	Immediately
	15h	H07-20	Reverse internal speed limit in torque control	-	0-6000	3000	1 RPM	16 bits	During running	Immediately
	16h	H07-21	Base value for torque reach	-	0-400	0	1%	16 bits	During running	Immediately
	17h	H07-22	Torque output value when torque reached DO signal turned on	-	0-400	20	1%	16 bits	During running	Immediately
	18h	H07-23	Torque output value when torque reached DO signal turned off	-	0-400	10	1%	16 bits	During running	Immediately
	19h	H07-24	Flux-weakening depth	-	60-115	115	100%	16 bits	During running	Immediately
	1Ah	H07-25	Maximum allowable demagnetizing current	-	1-100	100	100%	16 bits	During running	Immediately
	1Bh	H07-26	Flux-weakening enable	0: Disable 1: Enable	0-1	0	1	16 bits	During running	Immediately
	1Ch	H07-27	Flux-weakening gain	-	1-1000	30	1 Hz	16 bits	During running	Immediately
	25h	H07-36	Time constant of low-pass filter 2	-	0-10	0	1 ms	16 bits	During running	Immediately
	26h	H07-37	Torque reference filter selection	0: First-order filter 1: Biquad filter	0-1	0	1	16 bits	During running	Immediately
	27h	H07-38	Attenuation ratio of biquad filter	-	0-50	16	1	16 bits	At stop	Immediately
2008h/H08 Gain parameters										
2008	01h	H08-00	Speed loop gain	-	0.1-2000	39	1	16 bits	During running	Immediately
	02h	H08-01	Speed loop integral time constant	-	0.15-512	20.51	1 ms	16 bits	During running	Immediately
	03h	H08-02	Position loop gain	-	0.1-2000	55.7	1 Hz	16 bits	During running	Immediately
	04h	H08-03	2nd speed loop gain	-	0.1-2000	75	1 Hz	16 bits	During running	Immediately
	05h	H08-04	2nd speed loop integral time constant	-	0.15-512	10.61	1 ms	16 bits	During running	Immediately
	06h	H08-05	2nd position loop gain	-	0.1-2000	120	1 Hz	16 bits	During running	Immediately
	09h	H08-08	2nd gain mode setting	0: Fixed at the 1st gain, P/PI switchover through bit26 of 60FE 1: 1st/2nd gain switchover valid, with H08-09 as the switchover condition	0-1	1	1	16 bits	During running	Immediately

7 Appendix

Parameter Group			Name	Option Description	Value Range	Default	Min. Unit	Width	Setting Condition	Effective Time
Hexadecimal	Decimal	Para. No.								
Group	Index Code	Para. No.								
2008	0Ah	H08-09	Gain switchover condition	0: Fixed at 1st gain (PS) 1: Switchover through bit26 of 60FE 2: Torque reference too large (PS) 3: Speed reference too large (PS) 4: Speed reference change ratio too large (PS) 5: Speed reference high/low-speed threshold (PS) 6: Position deviation too large (P) 7: Position reference available (P) 8: Positioning unfinished (P) 9: Actual speed (P) 10: Position reference existed + Actual speed (P)	0-10	0	1	16 bits	During running	Immediately
	0Bh	H08-10	Gain switchover delay	-	0-1000	5	1 ms	16 bits	During running	Immediately
	0Ch	H08-11	Gain switchover level	-	0-20000	50	1	16 bits	During running	Immediately
	0Dh	H08-12	Gain switchover hysteresis	-	0-20000	30	1	16 bits	During running	Immediately
	0Eh	H08-13	Position gain switchover time	-	0-1000	3	1 ms	16 bits	During running	Immediately
	10h	H08-15	Load inertia ratio	-	0-120	3	1	16 bits	During running	Immediately
	12h	H08-17	Zero phase delay	-	0-4	0	1 ms	16 bits	During running	Immediately
	13h	H08-18	Speed feedforward filter time constant	-	0-64	0.5	1 ms	16 bits	During running	Immediately
	14h	H08-19	Speed feedforward gain	-	0-100	0	1%	16 bits	During running	Immediately
	15h	H08-20	Torque feedforward filter time constant	-	0-64	0.5	1 ms	16 bits	During running	Immediately
	16h	H08-21	Torque feedforward gain	-	0-300	0	1%	16 bits	During running	Immediately
	17h	H08-22	Speed feedback filter option	0: Average filter on speed feedback inhibited 1: 2 times of average filter on speed feedback 2: 4 times of average filter on speed feedback 3: 8 times of average filter on speed feedback 4: 16 times of average filter on speed feedback	0-4	0	1	16 bits	At stop	Immediately
	18h	H08-23	Cutoff frequency of low-pass filter of speed feedback		100-8000	8000	Hz	16 bits	During running	Immediately
	19h	H08-24	PDFF control coefficient		0-200	100	%	16 bits	During running	Immediately

Parameter Group			Name	Option Description	Value Range	Default	Min. Unit	Width	Setting Condition	Effective Time
Hexadecimal	Decimal	Para. No.								
Group	Index Code	Para. No.								
2008	1Ch	H08-27	Speed observer cutoff frequency	-	50-600	170	Hz	16 bits	During running	Immediately
	1Dh	H08-28	Speed observer inertia correction coefficient	-	1-1600	100	%	16 bits	During running	Immediately
	1Eh	H08-29	Speed observer filter time	-	0-10	0.8	ms	16 bits	During running	Immediately
	1Fh	H08-30	Disturbance compensation time	-	0-100	0.2	ms	16 bits	During running	Immediately
	20h	H08-31	Disturbance observation cutoff frequency	-	10-4000	600	Hz	16 bits	During running	Immediately
	21h	H08-32	Disturbance compensation gain	-	0-100	0	%	16 bits	During running	Immediately
	22h	H08-33	Disturbance observer inertia correction coefficient	-	1-1600	100	%	16 bits	During running	Immediately
	26h	H08-37	Phase modulation of medium-frequency suppression 2	-	-90 to +90	0	°	16 bits	During running	Immediately
	27h	H08-38	Frequency of medium-frequency suppression 2	-	0-1000	0	Hz	16 bits	During running	Immediately
	28h	H08-39	Compensation gain of medium-frequency suppression 2	-	1-300	0	%	16 bits	During running	Immediately
	29h	H08-40	Speed observer selection	0: Disabled 1: Enabled	0-1	0	1	16 bits	During running	Immediately
	2Bh	H08-42	Model control selection	0: Disabled 1: Enabled	0-1	0	1	16 bits	During running	Immediately
	2Ch	H08-43	Model gain	-	0.1-2000	40	1	16 bits	During running	Immediately
	2Fh	H08-46	Feedforward value	-	0-102.4	95	1	16 bits	During running	Immediately
	36h	H08-53	Medium and low frequency jitter suppression frequency 3	-	0-300	0	Hz	16 bits	During running	Immediately
	37h	H08-54	Medium- and low-frequency jitter suppression compensation 3	-	0-200	0	1%	16 bits	During running	Immediately
39h	H08-56	Medium- and low-frequency jitter suppression phase modulation 3	-	0-600	100	1%	16 bits	During running	Immediately	
3Ch	H08-59	Medium- and low-frequency jitter suppression frequency 4	-	0-300	0	Hz	16 bits	During running	Immediately	

7 Appendix

Parameter Group			Name	Option Description	Value Range	Default	Min. Unit	Width	Setting Condition	Effective Time
Hexadecimal	Decimal	Para. No.								
Group	Index Code	Para. No.								
2008	3Dh	H08-60	Medium- and low-frequency jitter suppression compensate 4	-	0-200	0	1%	16 bits	During running	Immediately
	3Eh	H08-61	Medium- and low-frequency jitter suppression phase modulation 4	-	0-600	100	1%	16 bits	During running	Immediately
	3Fh	H08-62	Position loop integral time constant	-	0.15-512	512	1	16 bits	During running	Immediately
	40h	H08-63	2nd position loop integral time constant	-	0.15-512	512	1	16 bits	During running	Immediately
	41h	H08-64	Speed observation feedback source	0: Disable 1: Enable	0-1	0	1	16 bits	During running	Immediately
	49h	H08-72	Viscous friction of zero deviation control	-	0-100	0	1	16 bits	During running	Immediately
	4Ah	H08-73	Forward coulomb friction of zero deviation control	-	0-100	0	1	16 bits	During running	Immediately
	4Bh	H08-74	Reverse coulomb friction of zero deviation control	-	-100-0	0	1	16 bits	During running	Immediately
	4Ch	H08-75	Friction compensation selection of zero deviation control	0: Disable 1: Enable	0-1	0	1	16 bits	During running	Immediately
	4Dh	H08-76	Acceleration compensation factor of zero deviation control	-	0-900	0	1	16 bits	During running	Immediately
	4Eh	H08-77	Static friction of zero deviation control	-	0-100	0	1	16 bits	During running	Immediately
	4Fh	H08-78	Speed of transition between coulomb friction and viscous friction of zero deviation control	-	0-100	0	1	16 bits	During running	Immediately
	50h	H08-79	Initial torque shock of zero deviation control	-	0-100	0	1	16 bits	During running	Immediately
	51h	H08-80	Friction compensation delay of zero deviation control	-	0-1000	20	1	16 bits	During running	Immediately

Parameter Group			Name	Option Description	Value Range	Default	Min. Unit	Width	Setting Condition	Effective Time
Hexadecimal	Decimal	Para. No.								
Group	Index Code	Para. No.	2009h/H09 Gain auto-tuning parameters							
2009	01h	H09-00	Gain auto-tuning mode	0: Invalid, gain parameters adjusted manually 1: Standard gain auto-tuning mode 2: Positioning mode 3: Interpolation mode + Inertia auto-tuning 4: Normal mode + Inertia auto-tuning 6: Quick positioning mode + Inertia auto-tuning	0-7	4	1	16 bits	During running	Immediately
	02h	H09-01	Stiffness level selection	-	0-41	15	1	16 bits	During running	Immediately
	03h	H09-02	Adaptive notch mode selection	0: Adaptive notch no longer updated 1: One adaptive notch activated (3rd notch) 2: Two adaptive notches activated (3rd and 4th notches) 3: Resonance point tested only, displayed in H09-24 4: Adaptive notch cleared, values of the 3rd and 4th notches restored to default settings	0-4	3	1	16 bits	During running	Immediately
	04h	H09-03	Online inertia auto-tuning mode	0: Online auto-tuning turned off 1: Online auto-tuning turned on, changing slowly 2: Online auto-tuning turned on, changing normally 3: Online auto-tuning turned on, changing quickly	0-3	2	1	16 bits	During running	Immediately
	06h	H09-05	Offline inertia auto-tuning mode	0: Bidirectional 1: Unidirectional	0-1	1	1	16 bits	At stop	Immediately
	07h	H09-06	Maximum speed of inertia auto-tuning	-	100-1000	500	1 RPM	16 bits	At stop	Immediately
	08h	H09-07	Time constant for accelerating to the maximum speed during inertia auto-tuning	-	20-800	125	1 ms	16 bits	At stop	Immediately
	09h	H09-08	Inertia auto-tuning interval	-	50-10000	800	1 ms	16 bits	At stop	Immediately
	0Ah	H09-09	Number of motor revolutions per inertia auto-tuning	-	0-100	1	1	16 bits	-	-

7 Appendix

Parameter Group			Name	Option Description	Value Range	Default	Min. Unit	Width	Setting Condition	Effective Time
Hexadecimal	Decimal	Para. No.								
Group	Index Code	Para. No.								
2009	0Ch	H09-11	Vibration threshold		0-100	5	1%	16 bits	During running	Immediately
	0Dh	H09-12	1st notch frequency	-	50-8000	8000	1 Hz	16 bits	During running	Immediately
	0Eh	H09-13	Width level of the 1st notch	-	0-20	2	1	16 bits	During running	Immediately
	0Fh	H09-14	Depth level of the 1st notch	-	0-99	0	1	16 bits	During running	Immediately
	10h	H09-15	2nd notch frequency	-	50-8000	8000	1 Hz	16 bits	During running	Immediately
	11h	H09-16	Width level of the 2nd notch	-	0-20	2	1	16 bits	During running	Immediately
	12h	H09-17	Depth level of the 2nd notch	-	0-99	0	1	16 bits	During running	Immediately
	13h	H09-18	3rd notch frequency	-	50-8000	8000	1 Hz	16 bits	During running	Immediately
	14h	H09-19	Width level of the 3rd notch	-	0-20	2	1	16 bits	During running	Immediately
	15h	H09-20	Depth level of the 3rd notch	-	0-99	0	1	16 bits	During running	Immediately
	16h	H09-21	4th notch frequency	-	50-8000	8000	1 Hz	16 bits	During running	Immediately
	17h	H09-22	Width level of the 4th notch	-	0-20	2	1	16 bits	During running	Immediately
	18h	H09-23	Depth level of the 4th notch	-	0-99	0	1	16 bits	During running	Immediately
	19h	H09-24	Auto-tuned resonance frequency	-	0-5000	0	1 Hz	16 bits	-	-
	1Fh	H09-30	Tension fluctuation compensation gain	-	-100 to +100	0	1	16 bits	During running	Immediately
	20h	H09-31	Tension fluctuation compensation filter time	-	0-25	0.5	1	16 bits	During running	Immediately
	21h	H09-32	Gravity compensation	-	0 to 100	0	1%	16 bits	During running	Immediately
	22h	H09-33	Forward friction compensation	-	0 to 100	0	1%	16 bits	During running	Immediately
	23h	H09-34	Reverse friction compensation	-	-100 to 0	0	1%	16 bits	During running	Immediately
	24h	H09-35	Friction compensation speed	-	0-20	2	1	16 bits	During running	Immediately
25h	H09-36	Friction compensation speed selection	0x00: Slow mode + Speed reference 0x01: Slow mode + Model speed 0x02: Slow mode + Speed feedback 0x10: Quick mode + Speed reference 0x11: Quick mode + Model speed 0x12: Quick mode + Speed feedback	0-0x12	0	1	16 bits	During running	Immediately	

Parameter Group			Name	Option Description	Value Range	Default	Min. Unit	Width	Setting Condition	Effective Time
Hexadecimal	Decimal	Para. No.								
Group	Index Code	Para. No.								
2009	26h	H09-37	Vibration monitoring time	-	0-65535	1200	1	16	During running	Immediately
	27h	H09-38	Low-frequency resonance suppression frequency 1 at the mechanical end	-	1-100	100	1 Hz	16 bits	During running	Immediately
	28h	H09-39	Low-frequency resonance suppression 1 at the mechanical end	-	0-3	2	1	16 bits	At stop	Immediately
	2Ah	H09-41	5th notch frequency	-	50-8000	8000	1 Hz	16 bits	During running	Immediately
	2Bh	H09-42	Width level of the 5th notch	-	0-20	2	1	16 bits	At stop	Immediately
	2Ch	H09-43	Depth level of the 5th notch	-	0-99	0	1	16 bits	At stop	Immediately
	2Dh	H09-44	Low-frequency resonance suppression frequency 2 at the mechanical end	-	0-200	0	1	16 bits	During running	Immediately
	2Eh	H09-45	Low-frequency resonance suppression response 2 at the mechanical end	-	0.01-10	1	1	16 bits	During running	Immediately
	30h	H09-47	Low-frequency resonance suppression width 2 at the mechanical end	-	0-2	1	1	16 bits	During running	Immediately
	32h	H09-49	Low-frequency resonance suppression frequency 3 at the mechanical end	-	0-200	0	1	16 bits	During running	Immediately
	33h	H09-50	Low-frequency resonance suppression response 3 at the mechanical end	-	0.01-10	1	1	16 bits	During running	Immediately
	35h	H09-52	Low-frequency resonance suppression width 3 at the mechanical end	-	0-2	1	1	16 bits	During running	Immediately
	39h	H09-56	STune mode setting	-	0-4	4	1	16 bits	During running	Immediately
	3Ah	H09-57	STune resonance suppression switching frequency	-	0-1500	850	1 Hz	16 bits	During running	Immediately
3Bh	H09-58	STune resonance suppression reset selection	0: Disable 1: Enable	0-1	0	1	16 bits	During running	Immediately	

7 Appendix

Parameter Group			Name	Option Description	Value Range	Default	Min. Unit	Width	Setting Condition	Effective Time
Hexadecimal	Decimal	Para. No.								
Group	Index Code									
200Ah/H0A Fault and Protection Parameters										
200A	01h	H0A-00	Power input phase loss protection	0: Enable 1: Hide Note: In common-bus connection mode, set 200A-01h to 1. Otherwise, the servo drive cannot enter "rdy" state after power-on.	0-3	0	1	16 bits	During running	Immediately
	02h	H0A-01	Absolute position limit selection	0: Disable 1: Enable 2: Enabled after homing	0-2	0	1	16 bits	At stop	Immediately
	05h	H0A-04	Motor overload protection gain	-	50-300	100	1	16 bits	At stop	Immediately
	09h	H0A-08	Overspeed threshold	-	0-20000	0	1 RPM	16 bits	During running	Immediately
	0Dh	H0A-12	Runaway protection	0: Disable 1: Enable	0-1	1	1	16 bits	During running	Immediately
	13h	H0A-18	IGBT over-temperature threshold	-	120-175	135	1°C	16 bits	During running	Immediately
	14h	H0A-19	Probe 1 filter time constant	-	0-6.3	2	1 μs	16 bits	During running	Immediately
	15h	H0A-20	Probe 2 filter time constant	-	0-6.3	2	1 μs	16 bits	During running	Immediately
	16h	H0A-21	STO function display selection	0: Displaying STO status 1: Displaying STO fault	0-1	0	1	16 bits	During running	Immediately
	18h	H0A-23	TZ signal filter time	-	0-31	15	125 ns	16 bits	At stop	Next power-on
	1Ah	H0A-25	Filter time constant of speed feedback display value	-	0-5000	50	1 ms	16 bits	At stop	Immediately
	1Bh	H0A-26	Motor overload selection	0: Not hide motor overload warning 1: Hide motor overload warning (E909.0) and fault (E620.0)	0-1	0	1	16 bits	At stop	Immediately
	1Ch	H0A-27	Speed DO filter time constant	-	0-5000	50	1 ms	16 bits	During running	Immediately
	21h	H0A-32	Time threshold for locked rotor over-temperature protection	-	10-65535	200	1 ms	16 bits	During running	Immediately
22h	H0A-33	Locked rotor over-temperature protection	0: Hide 1: Enable	0-1	1	1	16 bits	During running	Immediately	
25h	H0A-36	Encoder multi-turn overflow fault	0: Not hide 1: Hide	0-1	0	1	16 bits	During running	Immediately	
29h	H0A-40	Overtravel compensation switch	0: Compensation activated 1: Compensation inhibited	0-1	0	1	16 bits	At stop	Immediately	

Parameter Group			Name	Option Description	Value Range	Default	Min. Unit	Width	Setting Condition	Effective Time
Hexadecimal	Decimal	Para. No.								
Group	Index Code	Para. No.								
200A	32h	H0A-49	Regenerative resistor over-temperature threshold	-	100–175	115	1°C	16 bits	During running	Immediately
	33h	H0A-50	Encoder communication fault tolerance threshold	-	0–31	3	1	16 bits	During running	Immediately
	34h	H0A-51	Phase loss detection filter times	-	3–36	20	55 ms	16 bits	During running	Immediately
	35h	H0A-52	Encoder temperature protection threshold	-	0–150	0	1°C	16 bits	During running	Immediately
	38h	H0A-55	Runaway current threshold	-	100–400	200	1%	16 bits	During running	Immediately
	39h	H0A-56	Reset delay	-	0–60000	10000	1 ms	16 bits	During running	Immediately
	3Ah	H0A-57	Runaway speed threshold	-	1–1000	50	1 RPM	16 bits	During running	Immediately
	3Bh	H0A-58	Runaway speed filter time	-	0.1–100	2	1 ms	16 bits	During running	Next power-on
	3Ch	H0A-59	Runaway protection detection time	-	10–1000	30	1 ms	16 bits	During running	Immediately
	3Ch	H0A-70	Overspeed threshold	-	0–20000	0	1	16 bits	During running	Immediately
	3Ch	H0A-71	MS1 motor overload curve switchover	0: New overload curve 1: Old overload curve 2: Discharge upon power-off shielded 3: Old overload curve & Discharge upon power-off shielded	0–3	0	1	16 bits	During running	Immediately
	49h	H0A-72	Maximum time of ramp-to-stop	-	0–65535	10000	1 ms	16 bits	At stop	Immediately
4Ah	H0A-73	STO 24 V disconnection filter time	-	0–5	5	1 ms	16 bits	At stop	Immediately	
4Bh	H0A-74	STO fault tolerance filter time	-	0–10	10	1 ms	16 bits	At stop	Immediately	
4Ch	H0A-75	OFF delay after STO triggered	-	0–25	20	1 ms	16 bits	At stop	Immediately	

7 Appendix

Parameter Group			Name	Option Description	Value Range	Default	Min. Unit	Width	Setting Condition	Effective Time
Hexadecimal	Decimal	Para. No.								
Group	Index Code									
200Bh/H0B Monitoring parameters										
200B	01h	H0B-00	Speed feedback	-	-32767 to +32767	0	1 RPM	16 bits	-	-
	02h	H0B-01	Speed reference	-	-32767 to +32767	0	1 RPM	16 bits	-	-
	03h	H0B-02	Internal torque reference	-	-500 to +500	0	0.1%	16 bits	-	-
	04h	H0B-03	Monitored DI status	-	0-65535	0	1	32 bits	-	-
	06h	H0B-05	Monitored DO status	-	0-0xFFFF	0	1	16 bits	-	-
	08h	H0B-07	Absolute position counter	-	-2147483648 to +2147483647	0	1p	32 bits	-	-
	0Ah	H0B-09	Mechanical angle	-	0-3600	0	0.1°	16 bits	-	-
	0Bh	H0B-10	Electrical angle	-	0-3600	0	0.1°	16 bits	-	-
	0Dh	H0B-12	Average load ratio	-	0-800	0	1%	16 bits	-	-
	10h	H0B-15	Position following deviation (encoder unit)	-	-2147483648 to +2147483647	0	1p	32 bits	-	-
	12h	H0B-17	Feedback pulse counter	-	-2147483648 to +2147483647	0	1p	32 bits	-	-
	14h	H0B-19	Accumulative power-on time	-	0-4294967295	0	0.1s	32 bits	-	-
	19h	H0B-24	RMS value of phase current	-	0-6553.5	0	1 A	32 bits	-	-
	1Bh	H0B-26	Bus voltage	-	0-6553.5	0	1 V	16 bits	-	-
	1Ch	H0B-27	Power module temperature	-	-20 to +200	0	1°C	16 bits	-	-
	1Dh	H0B-28	Absolute encoder fault information given by FPGA	-	0-0xFFFF	0	1	16 bits	-	-
	1Eh	H0B-29	Axis status information given by FPGA	-	0-0xFFFF	0	1	16 bits	-	-
1Fh	H0B-30	Axis fault information given by FPGA	-	0-0xFFFF	0	1	16 bits	-	-	
20h	H0B-31	Encoder fault information	-	0-0xFFFF	0	1	16 bits	-	-	
22h	H0B-33	Fault log	-	0-9	0	1	16 bits	During running	Immediately	
23h	H0B-34	Fault code of the selected fault record	-	0-0xFFFF	0	1	16 bits	-	-	

Parameter Group			Name	Option Description	Value Range	Default	Min. Unit	Width	Setting Condition	Effective Time
Hexadecimal	Decimal	Para. No.								
Group	Index Code	Para. No.								
200B	24h	H0B-35	Time stamp upon occurrence of the selected fault	-	0-4294967295	0	0.1s	32 bits	-	-
	26h	H0B-37	Motor speed upon occurrence of the selected fault	-	-32767 to +32767	0	1 RPM	16 bits	-	-
	27h	H0B-38	Motor phase U current upon occurrence of the selected fault	-	-3276.7 to +3276.7	0	1 A	16 bits	-	-
	28h	H0B-39	Motor phase V current upon occurrence of the selected fault	-	-3276.7 to +3276.7	0	1 A	16 bits	-	-
	29h	H0B-40	Bus voltage upon occurrence of the selected fault	-	0-6553.5	0	V	16 bits	-	-
	2Ah	H0B-41	Input terminal state upon occurrence of the selected fault	-	0-65535	0	1	32 bits	-	-
	2Ch	H0B-43	Output terminal state upon occurrence of the selected fault	-	0-0xFFFF	0	1	16 bits	-	-
	2Eh	H0B-45	Internal fault code	-	0-0xFFFF	0	1	16 bits	-	-
	2Fh	H0B-46	Absolute encoder fault information given by FPGA upon occurrence of the selected fault	-	0-0xFFFF	0	1	16 bits	-	-
	30h	H0B-47	System state information given by FPGA upon occurrence of the selected fault	-	0-0xFFFF	0	1	16 bits	-	-
	31h	H0B-48	System fault information given by FPGA upon occurrence of the selected fault	-	0-0xFFFF	0	1	16 bits	-	-
	32h	H0B-49	Encoder fault information upon occurrence of the selected fault	-	0-0xFFFF	0	1	16 bits	-	-
	34h	H0B-51	Internal fault code upon occurrence of the selected fault	-	0-0xFFFF	0	1	16 bits	-	-
	36h	H0B-53	Position following deviation (reference unit)	-	-2147483648 to +2147483647	0	1p	32 bits	-	-
	38h	H0B-55	Actual motor speed	-	-6000 to +6000	0	1 RPM	32 bits	-	-
	3Ah	H0B-57	Bus voltage of control circuit	-	0-6553.5	0	1 V	16 bits	-	-
3Bh	H0B-58	Mechanical absolute position (low 32 bits)	-	-2147483648 to +2147483647	0	1p	32 bits	-	-	

7 Appendix

Parameter Group			Name	Option Description	Value Range	Default	Min. Unit	Width	Setting Condition	Effective Time
Hexadecimal	Decimal	Para. No.								
Group	Index Code	Para. No.								
200B	3Dh	H0B-60	Mechanical absolute position (high 32 bits)	-	-2147483648 to +2147483647	0	1p	32 bits	-	-
	40h	H0B-63	NotRdy status	0: None 1: Control circuit power error 2: Phase loss detection error 3: Main circuit power detection error (including short-to-ground fault) 4: Other servo faults 5: Short-to-ground detection not done	0-5	0	1	16 bits	-	-
	43h	H0B-66	Encoder temperature	-	-100 to +200	0	1°C	16 bits	-	-
	44h	H0B-67	Regenerative resistor load ratio	-	0-200	0	1%	16 bits	-	-
	47h	H0B-70	Number of absolute encoder revolutions	-	0-65535	0	1	16 bits	-	-
	48h	H0B-71	Position of the absolute encoder within one turn	-	0-2147483647	0	1p	32 bits	-	-
	4Eh	H0B-77	Encoder position (low 32 bits)	-	-2147483648 to +2147483647	0	1p	32 bits	-	-
	50h	H0B-79	Encoder position (high 32 bits)	-	-2147483648 to +2147483647	0	1p	32 bits	-	-
	52h	H0B-81	Single-turn position of the rotating load (low 32 bits)	-	0-4294967295	0	1p	32 bits	-	-
	54h	H0B-83	Single-turn position of the rotating load (high 32 bits)	-	-2147483648 to +2147483647	0	1p	32 bits	-	-
	56h	H0B-85	Single-turn position of the rotating load (reference unit)	-	-2147483648 to +2147483647	0	1p	32 bits	-	-
	5Bh	H0B-90	Group No. of the abnormal parameter	-	0-0xFFFF	0	1	16 bits	-	-
5Ch	H0B-91	Offset within the group of the abnormal parameter	-	0-65535	0	1	16 bits	-	-	

Parameter Group			Name	Option Description	Value Range	Default	Min. Unit	Width	Setting Condition	Effective Time
Hexadecimal	Decimal	Para. No.								
Group	Index Code									
200Dh/H0D Auxiliary function parameters										
200D	01h	H0D-00	Software reset	0: No operation 1: Enable	0-1	0	1	16 bits	At stop	Immediately
	02h	H0D-01	Fault reset	0: No operation 1: Enable	0-1	0	1	16 bits	At stop	Immediately
	04h	H0D-03	Encoder initial angle auto-tuning	0: No operation 1: Enable	0-1	0	1	16 bits	At stop	Immediately
	05h	H0D-04	Encoder ROM read/write	0: No operation 1: Write ROM 2: Read ROM	0-2	0	1	16 bits	At stop	Immediately
	06h	H0D-05	Emergency stop	0: No operation 1: Emergency stop	0-1	0	1	16 bits	During running	Immediately
	0Ch	H0D-12	UV phase current balance correction	0: Disable 1: Enable	0-1	0	1	16 bits	During running	Immediately
200D	12h	H0D-17	Forced DI/DO selection switch	0: No operation 1: Forced DI enabled, forced DO disabled 2: Forced DI disabled, forced DO enabled 3: Forced DI and DO enabled 4: EtherCAT forced DO enabled	0-4	0	1	16 bits	During running	Immediately
	13h	H0D-18	Forced DI setting value	-	0x00-0x1F	0	1	16 bits	During running	Immediately
	14h	H0D-19	Forced DO setting value	-	0x00-0x07	0	1	16 bits	During running	Immediately
	15h	H0D-20	Absolute encoder reset selection	0: No operation 1: Reset the encoder fault 2: Reset the encoder fault and multi-turn data	0-2	0	1	16 bits	At stop	Immediately
200Eh/H0E Auxiliary function parameters										
200E	01h	H0E-00	Node address	-	0-127	1	1	16 bits	During running	Immediately
	02h	H0E-01	Save objects written through communication to EEPROM	0: Not save parameters and object dictionaries written through communication to EEPROM 1: Save parameters written through communication to EEPROM 2: Save object dictionaries written through communication to EEPROM 3: Save parameters and object dictionaries written through communication to EEPROM	0-3	3	1	16 bits	During running	Immediately
	15h	H0E-20	EtherCAT slave name	-	0-65535	0	1	16 bits	-	-

7 Appendix

Parameter Group			Name	Option Description	Value Range	Default	Min. Unit	Width	Setting Condition	Effective Time
Hexadecimal	Decimal	Para. No.								
Group	Index Code	Para. No.								
200E	16h	H0E-21	EtherCAT slave alias	-	0-65535	0	1	16 bits	At stop	Immediately
	17h	H0E-22	Number of synchronization interrupts allowed by EtherCAT	-	1-20	9	1	16 bits	During running	Immediately
	18h	H0E-23	EtherCAT station alias from EEPROM	-	1-65535	0	1	16 bits	During running	Immediately
	19h	H0E-24	Synchronization loss count	-	0-65535	0	1	16 bits	-	-
	1Ah	H0E-25	Maximum value of invalid frames and errors of EtherCAT port 0 per unit time	-	0-0xFFFF	0	1	16 bits	-	-
	1Bh	H0E-26	Maximum value of invalid frames and errors of EtherCAT port 1 per unit time	-	0-0xFFFF	0	1	16 bits	-	-
	1Ch	H0E-27	Maximum value of transfer errors of EtherCAT port per unit time	-	0-0xFFFF	0	1	16 bits	-	-
	1Dh	H0E-28	Maximum value of EtherCAT data frame processing unit errors per unit time	-	0-0x0255	0	1	16 bits	-	-
	1Eh	H0E-29	Maximum value of link loss of EtherCAT port 0 per unit time	-	0-0xFFFF	0	1	16 bits	-	-
	20h	H0E-31	EtherCAT synchronization mode setting	-	0-2	1	1	16 bits	At stop	Next power-on
	21h	H0E-32	EtherCAT synchronization error threshold	-	100-4000	3000	1 μs	16 bits	At stop	Immediately
	22h	H0E-33	Connection state between EtherCAT state machine and the port	-	0-65535	0	1	16 bits	-	-
	23h	H0E-34	Excessive CSP position reference increment count	-	0-7	1	1	16 bits	During running	Immediately
	24h	H0E-35	AL fault code	-	0-65535	0	1	16 bits	-	-
	25h	H0E-36	EtherCAT AL enhanced link selection	0: Disable 1: Enable	0-1	0	1	16 bits	During running	Next power-on
	26h	H0E-37	EtherCAT reset XML selection	0: Disable 1: Enable	0-1	0	1	16 bits	During running	Next power-on

Parameter Group			Name	Option Description	Value Range	Default	Min. Unit	Width	Setting Condition	Effective Time
Hexadecimal	Decimal	Para. No.								
Group	Index Code	Para. No.								
200E	51h	H0E-80	Modbus baud rate	0: 300 bps 1: 600 bps 2: 1200 bps 3: 2400 bps 4: 4800 bps 5: 9600 bps 6: 19200 bps 7: 38400 bps 8: 57600 bps 9: 115200 bps	0-9	9	1	16 bits	During running	Immediately
	52h	H0E-81	Modbus data format	0: No parity, 2 stop bits (8-N-2) 1: Even parity, 1 stop bit (8-E-1) 2: Odd parity, 1 stop bit (8-O-1) 3: No parity, 1 stop bit (8-N-1)	0-3	3	1	16 bits	During running	Immediately
	53h	H0E-82	Modbus response delay	-	0-20	0	1 ms	16 bits	During running	Immediately
	54h	H0E-83	Modbus communication timeout	-	0-600	0	1 ms	16 bits	During running	Immediately
	5Bh	H0E-90	Modbus version number	-	0-655.35	0	1	16 bits	-	-
	5Eh	H0E-93	EtherCAT CoE version No.	-	0-655.35	0	1	16 bits	-	-
	61h	H0E-96	XML version No.	-	0-655.35	0	1	16 bits	-	-
2018h/H18 Position comparison output										
2018	01h	H18-00	Position comparison output selection	0: Disable 1: Enable (rising edge-triggered)	0-1	0	1	16 bits	During running	Immediately
	03h	H18-02	Position comparison value resolution	0: 24-bit 1: 23-bit 2: 22-bit 3: 21-bit 4: 20-bit 5: 19-bit 6: 18-bit 7: 17-bit	0-7	1	1	16 bits	During running	Immediately
	04h	H18-03	Position comparison mode selection	0: Individual comparison mode 1: Cyclic comparison mode	0-1	0	1	16 bits	During running	Immediately
	05h	H18-04	Current position as zero point	0: Disable 1: Enable (rising edge-triggered)	0-1	0	1	16 bits	During running	Immediately
	06h	H18-05	Position comparison output width	-	0-204.7	0	0.1 ms	16 bits	During running	Immediately
	08h	H18-07	Position comparison starting point	-	0-8	0	1	16 bits	During running	Immediately

7 Appendix

Parameter Group			Name	Option Description	Value Range	Default	Min. Unit	Width	Setting Condition	Effective Time
Hexadecimal	Decimal	Para. No.								
Group	Index Code	Para. No.								
2018	09h	H18-08	Position comparison end point	-	0-8	0	1	16 bits	During running	Immediately
	0Ah	H18-09	Current state of position comparison	-	0-8	0	1	16 bits	During running	Immediately
	0Bh	H18-10	Real-time position of position comparison	-	-2147483648 to +2147483647	0	1	32 bits	-	-
	0Dh	H18-12	Zero offset of position comparison	-	-2147483648 to +2147483647	0	1	32 bits	During running	Immediately
2019h/H19 Target position parameters										
2019	01h	H19-00	Target value of position comparison 1	-	-2147483648 to +2147483647	0	1	32 bits	During running	Immediately
	03h	H19-02	Attribute value of position comparison 1	0: Skip this point 1: Output DO active signal if current position changes from less than to more than the comparison point 2: Output DO active signal if current position changes from more than to less than the comparison point 3: Output DO active signal in both situations	0-3	0	1	16 bits	During running	Immediately
	04h	H19-03	Target value of position comparison 2	-	-2147483648 to +2147483647	0	1	32 bits	During running	Immediately
	06h	H19-05	Attribute value of position comparison 2	0: Skip this point 1: Output DO active signal if current position changes from less than to more than the comparison point 2: Output DO active signal if current position changes from more than to less than the comparison point 3: Output DO active signal in both situations	0-3	0	1	16 bits	During running	Immediately
	07h	H19-06	Target value of position comparison 3	-	-2147483648 to +2147483647	0	1	32 bits	During running	Immediately

Parameter Group			Name	Option Description	Value Range	Default	Min. Unit	Width	Setting Condition	Effective Time
Hexadecimal	Decimal	Para. No.								
Group	Index Code	Para. No.								
2019	09h	H19-08	Attribute value of position comparison 3	0: Skip this point 1: Output DO active signal if current position changes from less than to more than the comparison point 2: Output DO active signal if current position changes from more than to less than the comparison point 3: Output DO active signal in both situations	0-3	0	1	16 bits	During running	Immediately
	0Ah	H19-09	Target value of position comparison 4	-	-2147483648 to +2147483647	0	1	32 bits	During running	Immediately
	0Ch	H19-11	Attribute value of position comparison 4	0: Skip this point 1: Output DO active signal if current position changes from less than to more than the comparison point 2: Output DO active signal if current position changes from more than to less than the comparison point 3: Output DO active signal in both situations	0-3	0	1	16 bits	During running	Immediately
	0Dh	H19-12	Target value of position comparison 5	-	-2147483648 to +2147483647	0	1	32 bits	During running	Immediately
	0Fh	H19-14	Attribute value of position comparison 5	0: Skip this point 1: Output DO active signal if current position changes from less than to more than the comparison point 2: Output DO active signal if current position changes from more than to less than the comparison point 3: Output DO active signal in both situations	0-3	0	1	16 bits	During running	Immediately
	10h	H19-15	Target value of position comparison 6	-	-2147483648 to +2147483647	0	1	32 bits	During running	Immediately

7 Appendix

Parameter Group			Name	Option Description	Value Range	Default	Min. Unit	Width	Setting Condition	Effective Time
Hexadecimal	Decimal	Para. No.								
Group	Index Code	Para. No.								
2019	12h	H19-17	Attribute value of position comparison 6	0: Skip this point 1: Output DO active signal if current position changes from less than to more than the comparison point 2: Output DO active signal if current position changes from more than to less than the comparison point 3: Output DO active signal in both situations	0-3	0	1	16 bits	During running	Immediately
	13h	H19-18	Target value of position comparison 7	-	-2147483648 to +2147483647	0	1	32 bits	During running	Immediately
	15h	H19-20	Attribute value of position comparison 7	0: Skip this point 1: Output DO active signal if current position changes from less than to more than the comparison point 2: Output DO active signal if current position changes from more than to less than the comparison point 3: Output DO active signal in both situations	0-3	0	1	16 bits	During running	Immediately
	16h	H19-21	Target value of position comparison 8	-	-2147483648 to +2147483647	0	1	32 bits	During running	Immediately
	18h	H19-23	Attribute value of position comparison 8	0: Skip this point 1: Output DO active signal if current position changes from less than to more than the comparison point 2: Output DO active signal if current position changes from more than to less than the comparison point 3: Output DO active signal in both situations	0-3	0	1	16 bits	During running	Immediately

Object Group 6000h

The object group 6000h contains objects supported and related to DSP 402 profile.

Index (hex)	Sub-index (hex)	Name	Accessibility	PDO Mapping	Data Type	Unit	Data Range	Default	Setting Condition	Effective Time
603F	00	Error code	RO	TPDO	UInt16	-	-	-	-	-
6040	00	Control word	RW	RPDO	UInt16	-	0-0xFFFF	0	During running	Immediately
6041	00	Status word	RO	TPDO	UInt16	-	-	-	-	-
605A	00	Quick stop option code	RW	NO	Int16	-	0-0x07	0x02	During running	At stop
605C	00	Disable operation option code	RW	NO	Int16	-	0xFFFFD-0x01	0	During running	At stop
605D	00	Stop option code	RW	NO	Int16	-	0x01-0x03	0x01	During running	At stop
605E	00	Fault reaction option code	RW	NO	Int16	-	0xFFFFB-0x03	0x02	During running	At stop
6060	00	Modes of operation	RW	RPDO	Int8	-	0-0x0A	0	During running	Immediately
6061	00	Modes of operation display	RO	TPDO	Int8	-	-	-	-	-
6062	00	Position demand value	RO	TPDO	Int32	Reference unit	-	-	-	-
6063	00	Position actual value	RO	TPDO	Int32	Encoder unit	-	-	-	-
6064	00	Position actual value	RO	TPDO	Int32	Reference unit	-	-	-	-
6065	00	Following error window	RW	RPDO	UInt32	Reference unit	0-0xFFFFFFFF	0x00300000	During running	Immediately
6066	00	Following error time out	RW	RPDO	UInt32	ms	0-0xFFFF	0	During running	Immediately
6067	00	Position window	RW	RPDO	UInt32	Reference unit	0-0xFFFFFFFF	0x000002DE	During running	Immediately
6068	00	Position window time	RW	RPDO	UInt16	ms	0-0xFFFF	0	During running	Immediately
606C	00	Velocity actual value	RO	TPDO	Int32	Reference unit/s	-	-	-	-
606D	00	Velocity window	RW	RPDO	UInt16	RPM	0-0xFFFF	0x0A	During running	Immediately
606E	00	Velocity window time	RW	RPDO	UInt16	ms	0-0xFFFF	0	During running	Immediately
606F	00	Velocity threshold	RW	RPDO	UInt16	RPM	0-0xFFFF	0x0A	During running	Immediately
6070	00	Velocity threshold time	RW	RPDO	UInt16	ms	0-0xFFFF	0	During running	Immediately
6071	00	Target torque	RW	RPDO	Int16	0.1%	0xF448-0x0BB8	0	During running	Immediately
6072	00	Max torque	RW	RPDO	UInt16	0.1%	0-0x0BB8	0x0BB8	During running	Immediately
6074	00	Torque demand value	RO	TPDO	Int16	0.1%	-	0	-	-
6077	00	Torque actual value	RO	TPDO	Int16	0.1%	-	0	-	-

7 Appendix

Index (hex)	Sub-index (hex)	Name	Accessibility	PDO Mapping	Data Type	Unit	Data Range	Default	Setting Condition	Effective Time
607A	00	Target position	RW	RPDO	Int32	Reference unit	0x80000000–0x7FFFFFFF	0	During running	Immediately
607C	00	Home offset	RW	RPDO	Int32	Reference unit	0x80000000–0x7FFFFFFF	0	During running	Immediately
607D	Software absolute position limit									
	00	Highest sub-index supported	RO	NO	UInt8	-	-	0x02	-	-
	01	Min position limit	RW	RPDO	Int32	Reference unit	0x80000000–0x7FFFFFFF	0x80000000	During running	Immediately
	02	Max position limit	RW	RPDO	Int32	Reference unit	0x80000000–0x7FFFFFFF	0x7FFFFFFF	During running	Immediately
607E	00	Polarity	RW	RPDO	UInt8	-	0–0xFF	0	During running	Immediately
607F	00	Max profile velocity	RW	RPDO	UInt32	Reference unit/s	0–0xFFFFFFFF	0x06400000	During running	Immediately
6081	00	Profile velocity	RW	RPDO	UInt32	User speed unit	0–0xFFFFFFFF	0x001AAAAB	During running	Immediately
6083	00	Profile acceleration	RW	RPDO	UInt32	Reference unit/s ²	0–0xFFFFFFFF	0x0A6AAAAA	During running	Immediately
6084	00	Profile deceleration	RW	RPDO	UInt32	Reference unit/s ²	0–0xFFFFFFFF	0x0A6AAAAA	During running	Immediately
6085	00	Quick stop deceleration	RW	RPDO	UInt32	User acceleration unit	0–0xFFFFFFFF	0x7FFFFFFF	During running	Immediately
6086	00	Motion profile type	RW	RPDO	Int16	-	0x8000–0x7FFF	0	During running	Immediately
6087	00	Torque slope	RW	RPDO	UInt32	0.1%/s	0–0xFFFFFFFF	0xFFFFFFFF	During running	Immediately
6091	Gear ratio									
	00	Highest sub-index supported	RO	NO	UInt8	UInt8	-	0x02	-	-
	01	Motor revolutions	RW	RPDO	UInt32	-	0–0xFFFFFFFF	1	During running	Immediately
	02	Shaft revolutions	RW	RPDO	UInt32	-	1–0xFFFFFFFF	1	During running	Immediately
6098	00	Homing method	RW	RPDO	Int8	-	-2 to 35	0x01	During running	Immediately
6099	Homing speed									
	00	Highest sub-index supported	RO	NO	UInt8	-	-	0x02	-	-
	01	Speed during search for switch	RW	RPDO	UInt32	Reference unit/s	0–0xFFFFFFFF	0x001AAAAB	During running	Immediately
	02	Speed during search for zero	RW	RPDO	UInt32	Reference unit/s	0–0xFFFFFFFF	0x0002AAAB	During running	Immediately
609A	00	Homing acceleration	RW	RPDO	UInt32	Reference unit/s ²	0–0xFFFFFFFF	0x0A6AAAAA	During running	Immediately
60B0h	00	Position offset	RW	RPDO	Int32	Reference unit	0x80000000–0x7FFFFFFF	0	During running	Immediately
60B1h	00	Velocity offset	RW	RPDO	Int32	Reference unit/s	0x80000000–0x7FFFFFFF	0	During running	Immediately

Index (hex)	Sub-index (hex)	Name	Accessibility	PDO Mapping	Data Type	Unit	Data Range	Default	Setting Condition	Effective Time
60B2h	00	Torque offset	RW	RPDO	Int16	0.1%	0xF448–0x0BB8	0	During running	Immediately
60B8h	00	Touch probe function	RW	RPDO	UInt16	-	0–0xFFFF	0	During running	Immediately
60B9h	00	Touch probe status	RW	TPDO	UInt16	-	-	0	-	-
60BAh	00	Touch probe 1 positive edge	RW	TPDO	Int32	Reference unit	-	0	-	-
60BBh	00	Touch probe 1 negative edge	RW	TPDO	Int32	Reference unit	-	0	-	-
60BCh	00	Touch probe 2 positive edge	RW	TPDO	Int32	Reference unit	-	0	-	-
60BDh	00	Touch probe 1 negative edge	RW	TPDO	Int32	Reference unit	-	0	-	-
60C5h	0	Max acceleration	RW	RPDO	UInt32	User acceleration unit	0–0xFFFFFFFF	0xFFFFFFFF	During running	Immediately
60C6h	0	Max deceleration	RW	RPDO	UInt32	User acceleration unit	0–0xFFFFFFFF	0xFFFFFFFF	During running	Immediately
60D5h	0x00	Touch probe 1 positive edge counter	RO	TPDO	UInt16	-	-	0	-	-
60D6h	0x00	Touch probe 1 negative edge counter	RO	TPDO	UInt16	-	-	0	-	-
60D7h	0x00	Touch probe 2 positive edge counter	RO	TPDO	UInt16	-	-	0	-	-
60D8h	0x00	Touch probe 2 negative edge counter	RO	TPDO	UInt16	-	-	0	-	-
60E0h	00	Positive torque limit value	RW	RPDO	UInt16	0.1%	0–0x0BB8	0x0BB8	-	Immediately
60E1h	00	Negative torque limit value	RW	RPDO	UInt16	0.1%	0–0x0BB8	0x0BB8	-	Immediately

7 Appendix

Index (hex)	Sub-index (hex)	Name	Accessibility	PDO Mapping	Data Type	Unit	Data Range	Default	Setting Condition	Effective Time
Supported Homing Methods										
60E3h	00	Highest sub-index supported	RO	NO	Uint8	-	-	0x1F	-	-
	01	1st supported homing method	RO	NO	Uint16	-	-	0x0301	-	-
	02	2nd supported homing method	RO	NO	Uint16	-	-	0x0302	-	-
	03	3rd supported homing method	RO	NO	Uint16	-	-	0x0303	-	-
	04	4th supported homing method	RO	NO	Uint16	-	-	0x0304	-	-
	05	5th supported homing method	RO	NO	Uint16	-	-	0x0305	-	-
	06	6th supported homing method	RO	NO	Uint16	-	-	0x0306	-	-
	07	7th supported homing method	RO	NO	Uint16	-	-	0x0307	-	-
	08	8th supported homing method	RO	NO	Uint16	-	-	0x0308	-	-
	09	9th supported homing method	RO	NO	Uint16	-	-	0x0309	-	-
	0A	10th supported homing method	RO	NO	Uint16	-	-	0x030A	-	-
	0B	11th supported homing method	RO	NO	Uint16	-	-	0x030B	-	-
	0C	12th supported homing method	RO	NO	Uint16	-	-	0x030C	-	-
	0D	13th supported homing method	RO	NO	Uint16	-	-	0x030D	-	-
	0E	14th supported homing method	RO	NO	Uint16	-	-	0x030E	-	-
	0F	15th supported homing method	RO	NO	Uint16	-	-	0x030Fh	-	-
	10	16th supported homing method	RO	NO	Uint16	-	-	0x0310	-	-
	11	17th supported homing method	RO	NO	Uint16	-	-	0x0311	-	-
	12	18th supported homing method	RO	NO	Uint16	-	-	0x0312	-	-
13	19th supported homing method	RO	NO	Uint16	-	-	0x0313	-	-	
14	20th supported homing method	RO	NO	Uint16	-	-	0x0314	-	-	
15	21th supported homing method	RO	NO	Uint16	-	-	0x0315	-	-	
16	22th supported homing method	RO	NO	Uint16	-	-	0x0316	-	-	
17	23th supported homing method	RO	NO	Uint16	-	-	0x0317	-	-	
18	24th supported homing method	RO	NO	Uint16	-	-	0x0318	-	-	

Index (hex)	Sub-index (hex)	Name	Accessibility	PDO Mapping	Data Type	Unit	Data Range	Default	Setting Condition	Effective Time
60E3h	19	25th supported homing method	RO	NO	Uint16	-	-	0x0319	-	-
	1A	26th supported homing method	RO	NO	Uint16	-	-	0x031A	-	-
	1B	27th supported homing method	RO	NO	Uint16	-	-	0x031B	-	-
	1C	28th supported homing method	RO	NO	Uint16	-	-	0x031C	-	-
	1D	29th supported homing method	RO	NO	Uint16	-	-	0x031D	-	-
	1E	30th supported homing method	RO	NO	Uint16	-	-	0x031E	-	-
	1F	31th supported homing method	RO	NO	Uint16	-	-	0x031F	-	-
60E6h	00	Additional position encoder resolution – encoder increments	RW	NO	Uint16	-	0–1	0	During running	Immediately
60F4h	00	Following error actual value	RO	TPDO	Int32	Reference unit	-	-	-	-
60FCh	00	Position demand internal value	RO	TPDO	Int32	Encoder unit	-	-	-	-
60FDh	00	Digital inputs	RO	TPDO	Uint32	-	-	-	-	-
60FEh	Digital output									
	00	Highest sub-index supported	RO	NO	Uint8	-	-	0x02	-	-
	01	Physical outputs	RW	RPDO	Uint32	-	0–0xFFFFFFFF	0	During running	Immediately
	02	Bit mask	RW	NO	Uint32	-	0–0xFFFFFFFF	0	During running	Immediately
60FFh	00	Target velocity	RW	RPDO	Int32	Reference unit/s	0x80000000–0x7FFFFFFF	0	During running	Immediately
6502h	00	Supported drive modes	RO	NO	Uint32	-	-	0x000003AD	-	-

SDO Abort Transfer Code

Abort Code	Function Description
0503 0000	Trigger bits are not alternated.
0504 0000	Timeout occurs in the SDO protocol.
0504 0001	The client/server command word is invalid or unknown.
0504 0005	Memory overflow occurs.
0601 0000	Access to objects is not supported.
0601 0001	Indicates an attempt to read a write-only object.
0601 0002	Indicates an attempt to write a read-only object.
0602 0000	The object does not exist in the object dictionary.
0604 0041	The object cannot be mapped to the PDO.
0604 0042	The number and length of mapped objects exceed the PDO length.

Abort Code	Function Description
0604 0043	General parameters are incompatible.
0604 0047	General device content is incompatible.
0606 0000	Accessing objects fails due to a hardware error.
0607 0010	The data type does not match and the service parameter length does not match.
0607 0012	The data type does not match and the service parameter is too long.
0607 0013	The data type does not match and the service parameter is too short.
0609 0011	The sub-index does not exist.
0609 0030	The value exceeds the parameter value range.
0609 0031	The parameter value entered is too large.
0609 0032	The parameter value entered is too small.
0609 0036	The maximum value is smaller than the minimum value.
0800 0000	General error
0800 0020	Data cannot be transmitted or stored to the application.
0800 0021	Data cannot be transmitted or stored to the application due to local control.
0800 0022	Data cannot be transmitted or stored to the application due to current device status.
0800 0023	An error occurs in the object dictionary or the object dictionary does not exist.
0800 0024	The value does not exist.

7.3 Safe Torque Off (STO) Function

7.3.1 Description of Technical Terms

■ Terms and abbreviations:

Terms/Abbreviations	Description
Cat.	Classification of the safety-related parts of a control system. The categories are: B,1,2,3,4 (EN 13849-1).
CCF	Common cause failure
DC	Diagnostic coverage (%)
DTI	Diagnostic test interval time
SFF	Safe failure fraction
HFT	Hardware fault tolerance
PFH	Average frequency of dangerous failures per hour
PL	Performance level
SC	Systematic capability
SIL	Safety integrity level
T1	Proof test interval
T2	Diagnostic test interval
DI	Digital input
DO	Digital output
PCB	Printed circuit board
MCU	Micro computer unit
FPGA	Center processor unit

■ Description of technical terms:

Terms	Description
Safe Torque Off (STO)	The STO function brings the machine safely into a no-torque state and prevents it from unexpected starting. If the motor is running when STO function is activated, it coasts to a stop.
Safe state	Used to disable the PWM gating signal of the drive.
System reset	Reset the servo system by shutting off the power or executing software reset.
Proof test	Used to detect the failure of the safety-related system, not applied to STO circuits.
Mission time	Refers to the specified cumulative operating time of the safety-related parts of the servo drive during its overall lifetime.

Overview of the safety drive with safety function is shown in Fig 11-1. The parts marked in the orange dashed line is the safety-related. They are integrated in the control board of the drive.

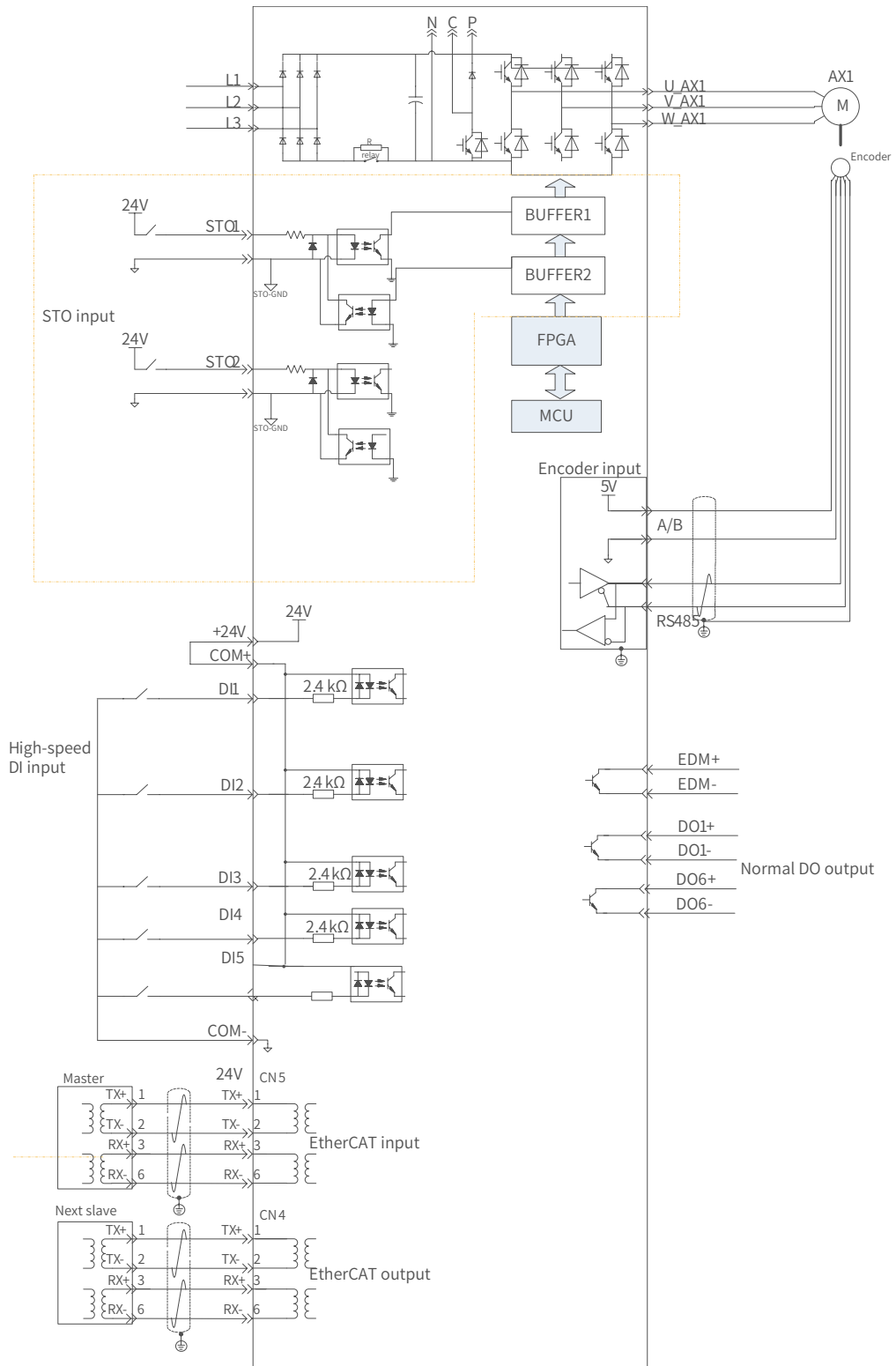

Figure 7-11 Overview of the safety drive

7.3.2 Standards Compliance

- North American Standards (UL)

UL 61800-5-1

CSA C22.2 No. 274

- European Directives and Standards

Low Voltage Directive 2014/35/EU; Standards EN 61800-5-1

Electromagnetic Compatibility Directive 2014/30/EU; Standards EN 61800-3, EN 61800-3, and EN 61800-5-2

Machinery Directive 2006/42/EC (functional safety); Standard EN 61800-5-2

- Safety Standards

Model	Safety Standards	Standards
SV630NXXX	Safety standards	Standards
	Functional Safety	EN 61800-5-2: 2017 EN ISO 13849-1: 2015 EN 62061: 2005 + AC: 2010 + A1: 2013 + A2: 2015 EN 61508: 2010, parts 1-7
	Electromagnetic Compatibility (EMC)	EN 61800-5-2: 2017 EN 61800-3:2018
	LVD	EN 61800-5-1:2007+A1: 2017 (in extracts)

- Safety Performance

Items	Performance level
Safety integrity level	SIL3
	SILCL3
Probability of Dangerous Failure per Hour (PFH)	$PFH \leq 0.1 \times 10^{-7}$ [1/h] (10% of SIL3)
Performance level (PL)	PL e (category 3)
Mean time to dangerous failure of each channel	MTTFd: High
Ave. diagnostic coverage	DCave: Medium
Stop category	Stop category 0
Safety function	STO
Mission time	5 years
Hardware fault tolerance (HFT)	1
Systematic capability (SC)	3
Application mode	High demand or continuous mode





7.3.3 General Safety Information



This section contains the warning symbols used in this user guide and the safety instructions which you must obey when you install, use or maintenance a safety option module of a servo drive. If you ignore the safety instructions, injury, death or damage may occur. Read this section before you start the installation.

Any illustrations, photographs, or examples used in this manual are provided as examples only and may not apply to all products to which this user guide is applicable.

The products and specifications described in this user guide or the content and presentation of the user guide may be changed without notice to improve the product and/or the user guide.

■ Warnings, Cautions and Notes

Pictogram	Signal word	Meaning	Consequences In Case of Disregard
Example: 	DANGER	Imminent danger	Severe or fatal injuries
General danger 	WARNINGS	Possible dangerous situation	Severe or fatal injuries
Specific danger (such as electric shock)	CAUTION	Possible dangerous situation	Minor injuries
	STOP!	Possible high dangerous	Damage to the drive system or its environment
 NOTE	NOTE	A Note containing information or tip which helps ensure correct operation of the product	-

 WARNING	
	<ul style="list-style-type: none"> ◆ High attention is required for electrical installation and at the system design to avoid hazards either in normal operation or in the event of equipment malfunction. ◆ System design, installation, commissioning and maintenance must be carried out by personnel who have the necessary training and experience. They must read the operating instruction and this safety information.

It is the responsibility of the machine builder/OEM/system integrator to make sure that the essential health and safety requirements specified in the Machinery Directive are met. Risk analysis and risk assessment is needed before using a product. Make sure that adequate measures are taken to eliminate/reduce the relating risks and components chosen must meet the safety requirements.

7.3.4 Specifications

- Electrical safety complies with EN 61800-5-1:2016, over voltage category III .
- The environment test requirement complies with EN 61800 -5-1.
- The operating conditions are as follows.

Items	Description																				
Surrounding air/Storage temperature	0°C to 55°C /-20°C to +70°C																				
Ambient/Storage humidity	20%–95% RH (without condensation)																				
Vibration	<table border="1"> <thead> <tr> <th>Subject</th> <th>Test conditions</th> </tr> </thead> <tbody> <tr> <td>Test reference</td> <td>Test Fc of IEC 60068-2-6 4.6</td> </tr> <tr> <td>Conditions</td> <td>The EUT is powered up and operating normally.</td> </tr> <tr> <td>Motion</td> <td>Sinusoidal</td> </tr> <tr> <td>Vibration amplitude/ acceleration</td> <td>-</td> </tr> <tr> <td>10 Hz ≤ f ≤ 57 Hz</td> <td>0.075 mm amplitude</td> </tr> <tr> <td>57 Hz < f ≤ 150 Hz</td> <td>1 g</td> </tr> <tr> <td>Vibration duration</td> <td>10 sweep cycles per axis on each of three mutually perpendicular axes</td> </tr> <tr> <td>Axes</td> <td>X, Y, Z</td> </tr> <tr> <td>Detail of mounting</td> <td>According to manufacturer's specification</td> </tr> </tbody> </table>	Subject	Test conditions	Test reference	Test Fc of IEC 60068-2-6 4.6	Conditions	The EUT is powered up and operating normally.	Motion	Sinusoidal	Vibration amplitude/ acceleration	-	10 Hz ≤ f ≤ 57 Hz	0.075 mm amplitude	57 Hz < f ≤ 150 Hz	1 g	Vibration duration	10 sweep cycles per axis on each of three mutually perpendicular axes	Axes	X, Y, Z	Detail of mounting	According to manufacturer's specification
	Subject	Test conditions																			
	Test reference	Test Fc of IEC 60068-2-6 4.6																			
	Conditions	The EUT is powered up and operating normally.																			
	Motion	Sinusoidal																			
	Vibration amplitude/ acceleration	-																			
	10 Hz ≤ f ≤ 57 Hz	0.075 mm amplitude																			
	57 Hz < f ≤ 150 Hz	1 g																			
	Vibration duration	10 sweep cycles per axis on each of three mutually perpendicular axes																			
	Axes	X, Y, Z																			
Detail of mounting	According to manufacturer's specification																				
Shock resistance	<table border="1"> <thead> <tr> <th>Subject</th> <th>Test conditions</th> </tr> </thead> <tbody> <tr> <td>Test reference</td> <td>Test Ea of IEC 60068-2-27: 2008 Table 17</td> </tr> <tr> <td>Conditions</td> <td>The EUT is powered up and operating normally.</td> </tr> <tr> <td>Motion</td> <td>Half-sine pulse</td> </tr> <tr> <td>Shock amplitude/ time</td> <td>50 m/s² (5 g) 30 ms</td> </tr> <tr> <td>Number of shocks</td> <td>3 per axis on each of three mutually perpendicular axes</td> </tr> <tr> <td>Axes</td> <td>±X, ±Y, ±Z</td> </tr> <tr> <td>Detail of mounting</td> <td>According to manufacturer's specification</td> </tr> </tbody> </table>	Subject	Test conditions	Test reference	Test Ea of IEC 60068-2-27: 2008 Table 17	Conditions	The EUT is powered up and operating normally.	Motion	Half-sine pulse	Shock amplitude/ time	50 m/s ² (5 g) 30 ms	Number of shocks	3 per axis on each of three mutually perpendicular axes	Axes	±X, ±Y, ±Z	Detail of mounting	According to manufacturer's specification				
	Subject	Test conditions																			
	Test reference	Test Ea of IEC 60068-2-27: 2008 Table 17																			
	Conditions	The EUT is powered up and operating normally.																			
	Motion	Half-sine pulse																			
	Shock amplitude/ time	50 m/s ² (5 g) 30 ms																			
	Number of shocks	3 per axis on each of three mutually perpendicular axes																			
	Axes	±X, ±Y, ±Z																			
Detail of mounting	According to manufacturer's specification																				
IP rating/Pollution degree (PD)	IP 20 PD 2: free of corrosive or explosive gases; free of exposure to water, oil or chemicals; free of dust, salts or iron dust																				
Altitude	2000 m or below																				
Cooling method	Dry clean air (natural convection)																				
Others	Free of static electricity, strong electromagnetic fields, magnetic fields or exposure to radioactivity																				

- The servo drive follows the EMC standards EN 61800-3:2018, EN 61326-3-1, and EN 61800-5-2.

- Others

Items	Description
Applicable Servo Drive	SV630NS1R6I-FS SV630NS2R8I-FS SV630NS5R5I-FS SV630NS6R6I-FS SV630NS7R6I-FS SV630NS012I-FS SV630NT3R5I-FS SV630NT5R4I-FS SV630NT8R4I-FS SV630NT012I-FS SV630NT017I-FS SV630NT021I-FS SV630NT026I-FS
Location	Integrated in the control board of the servo drive
Safety function - Inputs	2 channels: STO1/STO2

The STO subsystem elements must always operate within the range of temperature, humidity, corrosion, dust, vibration, and other items specified above.

7.3.5 Installation

Since the STO function is integrated in the control board of the servo drive, its installation requirements are consistent with the servo drive. Observe the installation requirements of the servo drive.

Designers and installers must be trained to understand the requirements and principles of designing and installing safety-related systems.

7.3.6 Terminal and Wiring

This section describes the definition and function of the I/O connecting terminal (CN6) for STO.

See details in ["3.7 Definition and Connection of STO terminals"](#).

7.3.7 Requirement for Commission, Operation and Maintenance

1 General

- Technicians must be trained to understand the requirements and principles of designing and commissioning safety-related systems.
- Those performing the maintenance must be trained to understand the requirements and principles of designing and operating safety-related systems.
- Operators must be trained to understand the requirements and principles of designing and operating safety-related systems.
- If the safety-related circuits on the control board fails to operate, replace it with a new one because it is not repairable.

2 Commissioning checklists

- Start-up test and validation

EN 61508, EN 62061 and EN ISO 13849 require that the final assembler of the machine validates the operation of the safety function with an acceptance test. The acceptance tests for the standard safety functions of the drive are described in the drive manuals.

The acceptance test must be performed:

- 1) at initial start-up of the safety function
- 2) after any changes related to the safety function (including wiring, components, and settings)
- 3) after any maintenance work related to the safety function.

The acceptance test of the safety function must be carried out by an authorized person with expertise and knowledge of the safety function. The test must be documented and signed by the authorized person.

Signed acceptance test reports must be stored in the logbook of the machine. The report shall include documentation of start-up activities and test results, references to failure reports and resolution of failures. Any new acceptance tests performed due to changes or maintenance need to be logged into the logbook.

■ Start-up checklist

Step	Action	Result
1	Ensure that the servo drive can run and stop freely during the commissioning.	
2	Stop the servo drive (if running), switch the input power off and isolate the drive from the power line by a circuit breaker.	
3	Check the STO circuit connections against the circuit diagram.	
4	Check that the shield of the STO input cable is grounded to the drive frame.	
5	Close the circuit breaker and switch the power on.	
5.1	<p>Test the STO signal #1 when the motor is stopped.</p> <p>Set STO1 and STO2 to "H".</p> <p>Give a stop command for the drive (if running) and wait until the motor shaft is at standstill.</p> <p>Activate the STO function by disconnecting (low state or open-circuit) the STO input signal #1 and give a start command for the drive.</p> <p>Ensure that the motor stays at standstill and the LED display of the servo drive displays "E150.1".</p>	
5.2	Set STO1 to "H", disable the ON/RUN command of the drive, then automatically reset the drive, enable ON/RUN command of the drive and check that the motor runs normally.	
5.3	<p>Test the STO signal #2 when the motor is stopped.</p> <p>Set STO1 and STO2 to "H".</p> <p>Give a stop command for the drive (if running) and wait until the motor shaft is at standstill.</p> <p>Activate the STO function by disconnecting (low state or open-circuit) the STO input signal #2 and give a start command for the drive.</p> <p>Ensure that the motor stays at standstill and the LED display of the servo drive displays "E150.1".</p>	
5.4	Set STO2 to "H", disable the ON/RUN command of the drive, then automatically reset the drive, enable ON/RUN command of the drive and check that the motor runs normally.	

Step	Action	Result
6.1	<p>Test the STO channel #1 when the motor is running.</p> <p>Set STO1 and STO2 to "H".</p> <p>Start the drive and ensure the motor is running.</p> <p>Activate the STO function by disconnecting (low state or open-circuit) the STO input signal #1.</p> <p>Ensure that the motor stops and the drive trips.</p> <p>Reset the fault and try to start the drive.</p> <p>Ensure that the motor stays at standstill and the LED display of the servo drive displays "E150.1".</p>	
6.2	<p>Set STO1 to "H", disable the ON/RUN command of the drive, then automatically reset the drive, enable ON/RUN command of the drive and check that the motor runs normally.</p>	
6.3	<p>Test the STO channel #2 when the motor is running.</p> <p>Set STO1 and STO2 to "H".</p> <p>Start the drive and ensure the motor is running.</p> <p>Activate the STO function by disconnecting (low state or open-circuit) the STO input signal #2.</p> <p>Ensure that the motor stops and the drive trips.</p> <p>Reset the fault and try to start the drive.</p> <p>Ensure that the motor stays at standstill and the LED display of the servo drive displays "E150.1".</p>	
6.4	<p>Set STO2 to "H", disable the ON/RUN command of the drive, then automatically reset the drive, enable ON/RUN command of the drive and check that the motor runs normally.</p>	
7	<p>Document and sign the acceptance test report which verifies that the safety function is safe and accepted to operation.</p>	

3 Special requirements

To fulfill SIL 3 PL e (cat3), power off the servo drive once per 3 months to perform the power-on diagnostic.

7.3.8 Safety Function: STO

1 Description of safety function

Safe Torque Off (STO) is a safety function that complies with EN 61800-5-2:2017. It is built into Inovance SV630N series servo drives.

The STO function prohibits the control signal of the power semiconductors of the drive output end, preventing the drive from generating torque at the motor shaft end.

The STO function prevents the movement of the motor by two redundant external hardware signals: STO1 and STO2 that block the PWM signals to be transmitted to the power layer of the drive. These two +24VDC signals must be active to enable the drive's normal operations.

If either one or both signals are set low, the PWM signals are blocked within a time of 30 ms.

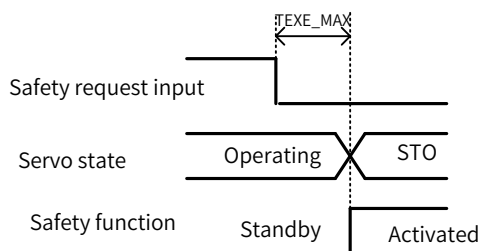

- The STO function table is as follows.

STO1 Input	STO2 Input	PWM Signal
H	H	Normal
L	H	Inhibited
H	L	Inhibited
L	L	Inhibited

STO (Safe Torque Off)	
Definition	Cuts off the force-producing power to the motor.
Description	The STO function brings the machine safely into a no-torque state and prevents it from unexpected starting. If the motor is running when STO function is activated, it coasts to a stop.
Safe state	Used to disable the PWM gate signals of the drive.
Operating mode	High demand mode or continuous mode

2 Application example of safety function

- Example 1: Direct Stop, stop category 0, safety stop: STO

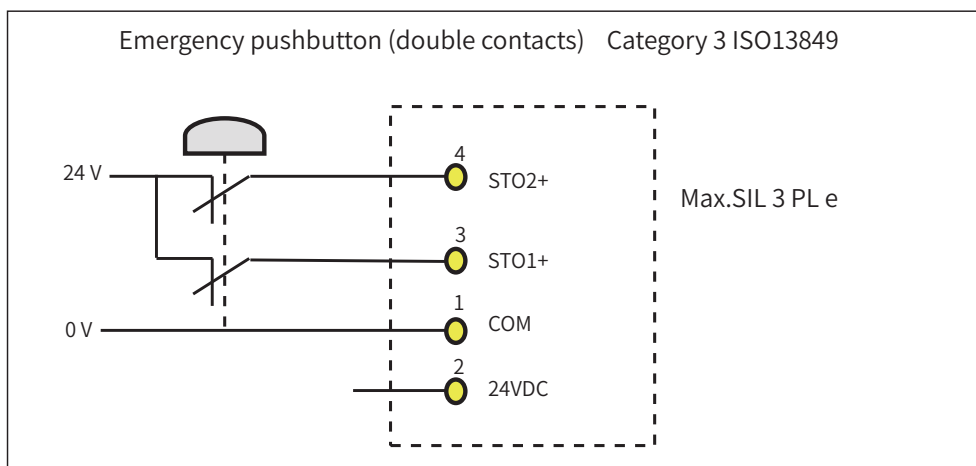

3 Monitoring of safety function

The LED display of the servo drive displays the selected mode, the status, and the error information of the servo drive.

Error: Displays drive fault code.

You can select and modify the configuration through the keypad. See ["4 Keypad Display and Operations"](#) for the definition of the keypad.

- Fault codes related to the STO function are shown below.

Fault code	Status	Description
E150.0	STO activated by external request	Both of STO1/STO2 in "Low" state
E150.1	Status of STO1/STO2 not consistent	Only one of STO1/STO2 in "Low" state, status of STO1/STO2 inconsistent
E150.2	STO activated by internal diagnosis	OV/UV of 5 V power supply detected
E150.3	STO activated by internal diagnosis	Input circuits of STO working abnormally
E150.4	STO activated by internal diagnosis	Buffer circuits of STO working abnormally

4 STO status during exceptional operations

The exceptional operation refers to the duration of power-on and initialization, and how to return from the STO state.

- 1) The PWM buffer is disabled through pulling-up of the enable terminal during power-on, so the PWM signal is prohibited.
- 2) The PWM buffer is disabled through pulling-up of the enable terminal during initialization of MCU, so the PWM signal is prohibited. This condition is relieved once the initialization phase is finished and servo drive works normally.
- 3) When servo system enters safe state through the STO function, the safe state can be cleared to return to normal operation after auto-reset of the drive when all of the following conditions are met:

- The input state of the STO request must be "high".
- The S-ON or RUN command must be inactive.
- No dangerous faults exist.

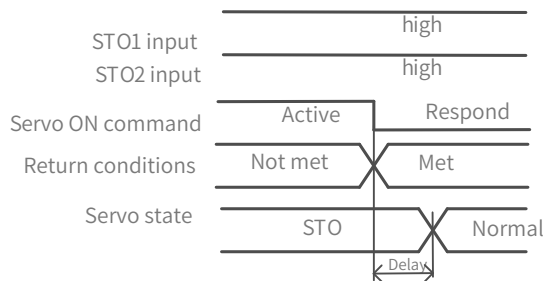

Figure 12-12 Return condition of S-ON/RUN command

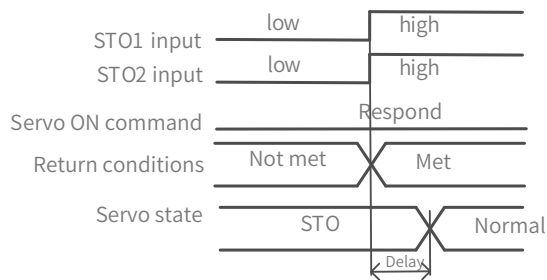

Figure 7-13 Return condition of external STO request state

7.3.9 Troubleshooting

See the following table to identify the fault cause and the action to be taken. Contact your Inovance representative if the problem cannot be solved by the described corrective actions. Fault codes related to the STO function are shown below.

Fault Code	Cause	Action
E150.0	STO1/STO2 not connected to the 24 V input voltage	Connect the STO1 and STO2 to the 24 V input voltage signal.
E150.1	Input states of STO1/STO2 being inconsistent	1) Ensure the requests for disconnecting the voltage of STO1 and STO2 are triggered simultaneously. 2) The input circuit is abnormal and a certain STO input signal is still in "High" status after the 24 V signal is disconnected. Contact Inovance for technical support.
E150.2	OV/UV of 5 V power supply detected	Restore the 5 V power supply to normal state. Contact Inovance for technical support.
E150.3	Input circuit of STO working abnormally	Fix the input circuit fault. Contact Inovance for technical support.
E150.4	Buffer circuit of STO working abnormally	Fix the buffer circuit fault. Contact Inovance for technical support.

7.3.10 Product Information

1 Nameplate and model number

See [“1.1.1 Nameplate and Model Number”](#) for details.

2 Applicable servo drive

STO applies to the servo drives in the following two kinds of physical structures.

Size	Power Range	Physical Structure	W x H x D (mm ³)
A	200 W to 400 W	Integrated structure	40 x 160 x 150
B	750 W to 850 W	Integrated structure	50 x 160 x 173
C	1 kW to 1.5 kW	Separated structure	55 x 170 x 173
D	1.8 kW to 3 kW	Separated structure	75 x 170 x 183
E	5 kW to 7.5 kW	Separated structure	90 x 250 x 230

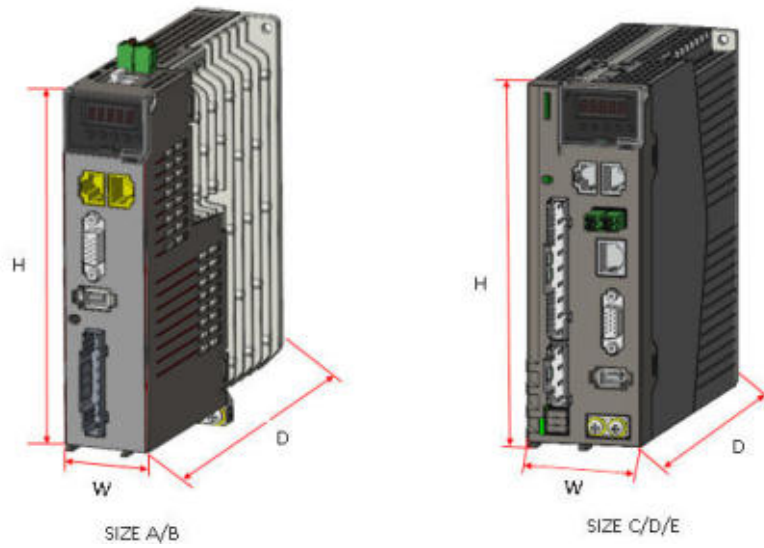

NOTE

Integrated structure means that the control parts and power parts are on the same PCB.

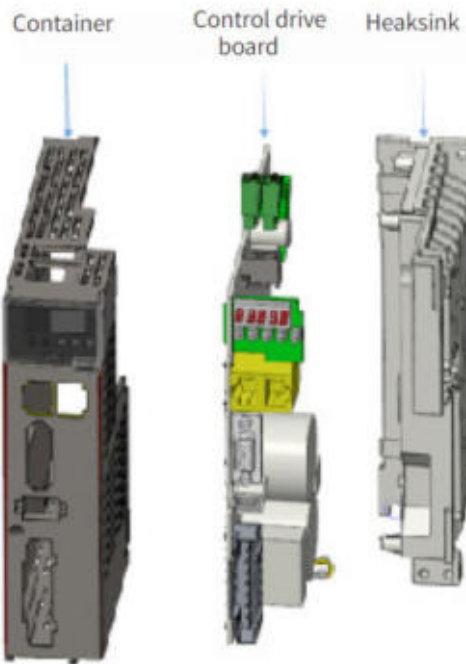

NOTE

Separated structure means that the control parts and power parts are on different PCBs.

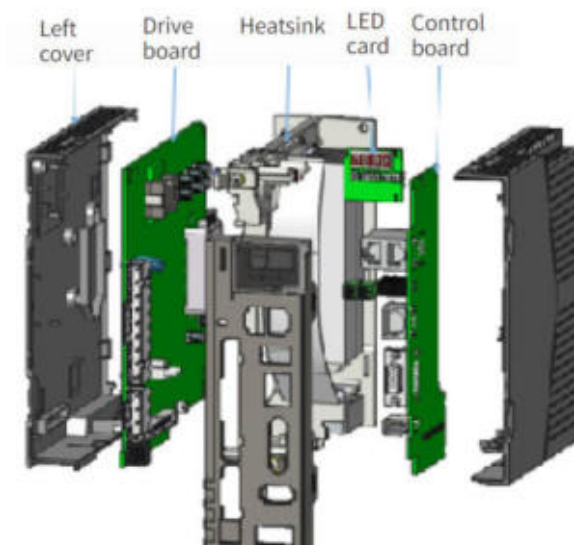

7.3.11 Precautions

This section describes the information needed before starting operation. Be sure to read the following safety instructions, risk assessment information, and limitations before starting operation. Safety function: use the STO function after properly understanding all of these information.

1 Safety protective measures



Carefully read the following important precautions and observe them when using the safety function STO.



- The STO function is not intended as a replacement for an Emergency Stop function (E-stop). In an emergency situation, the power supply cannot be cut off if no other measure is taken, and the electrical parts of the motor and drive are still energized, incurring the risk of electric shock or other risks. Therefore, maintenance work on electrical parts of the drive or motor can only be carried out after isolating the drive system from the main power supply.
- Depending on the standards and requirements for a particular application, it may be possible to use STO as an integral part of an E-stop system. However, its main purpose is for use in a dedicated safety control arrangement whose purpose is to prevent any hazard from occurring, not for the use of an E-stop.
- An E-stop is often provided in a machine to allow for unexpected situations where an operator sees a hazard and can take action to prevent an accident.
- The design requirement for an E-stop differs from that of a safety interlock. Generally, the E-stop is required to be independent from any complex or intelligent control. It may use purely electromechanical devices to either disconnect the power or initiate a controlled quick stop through other means such as dynamic or regenerative braking.



NOTE

In the use of permanent-magnet motors, reluctance motors, and salient-pole induction motors, in spite of the activation of the STO function, a possible (although highly unlikely) failure mode may cause two power devices in the drive to conduct incorrectly. The drive system can produce an alignment torque which maximally rotates the motor shaft by 180° electrical angle for a permanent-magnet motor, or by 90° electrical angle for a salient pole induction motor or reluctance motor. This possible failure mode must be allowed for in the machine system design.

 WARNING	
	Max. rotating angle of the motor shaft = $\frac{360^\circ \text{ electrical angle}}{\text{Motor poles number}}$

 WARNING	
	<ul style="list-style-type: none"> ◆ The design of safety-related systems requires specialist knowledge. To ensure that a complete control system is safe, the whole system needs to be designed according to recognized safety principles. The use of individual sub-systems such as drives with STO function, which are intended for safety-related applications, does not in itself ensure the safety of the complete system. ◆ The STO function can be used for stopping the servo drive in emergency stop situations. ◆ In normal operating mode, it is recommended not to stop the servo drive by using the STO function. If a drive running is stopped by using STO, the drive perform a coast to stop. If this is not acceptable, the system must be stopped using the correct mode instead of the STO function. ◆ This publication is a guide to the application of Inovance STO function, and also on the design of safety-related systems for machinery control. ◆ It is the responsibility of the designer of the end product or application to ensure that it is safe and in compliance with the relevant regulations.

2 Risk assessment

- When using the safety function STO, be sure to perform risk assessment of the servo system in advance. Make sure that the safety integrity level of the standards is met.
- The following residual risks can be present even when the safety functions operate. Therefore, safety must always be given consideration during risk assessment.
- If external forces (such as gravitational force with a vertical axis) are applied when the safety functions are operating, the motor will rotate due to the action of these external forces. Use a separate mechanical brake to secure the motor.
- If the servo drive fails, the motor may operate within a range of 180 electrical degrees. Make sure that safety is ensured even in hazardous situations.
- The number of rotations and movement distance for each type of motor are listed below.

Rotational motor: 1/6 rotation max. (rotation angle at motor shaft conversion), depending on the number of motor pole pairs

Direct drive motor: 1/20 rotation max. (rotation angle at motor shaft conversion), depending on the number of motor pole pairs

Linear servo motor: 30 mm max., depending on the number of motor pole pairs



19011627A00

Copyright © Shenzhen Inovance Technology Co., Ltd.

Shenzhen Inovance Technology Co., Ltd.

www.inovance.com

Add.: Inovance Headquarters Tower, High-tech Industrial Park,
Guanlan Street, Longhua New District, Shenzhen

Tel: (0755) 2979 9595 **Fax:** (0755) 2961 9897

Suzhou Inovance Technology Co., Ltd.

www.inovance.com

Add.: No. 16 Youxiang Road, Yuexi Town,
Wuzhong District, Suzhou 215104, P.R. China

Tel: (0512) 6637 6666 **Fax:** (0512) 6285 6720